



सत्यमेव जयते

GOVERNMENT OF INDIA

# SWACHH BHARAT MISSION

## MUNICIPAL SOLID WASTE MANAGEMENT MANUAL

### PART II: THE MANUAL

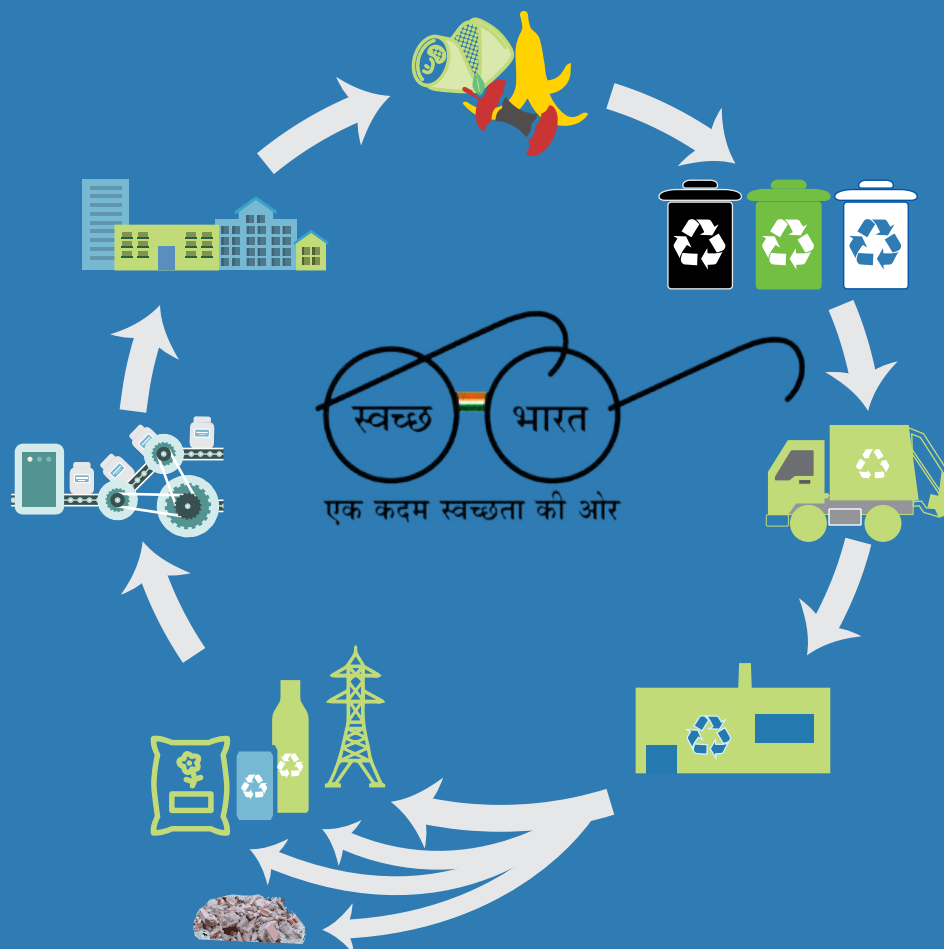

Central Public Health and Environmental Engineering Organisation (CPHEEO)

**MINISTRY OF URBAN DEVELOPMENT**

[www.moud.gov.in](http://www.moud.gov.in)

[www.swachhbharaturban.gov.in](http://www.swachhbharaturban.gov.in)

**2016**





सत्यमेव जयते

GOVERNMENT OF INDIA  
**MINISTRY OF URBAN DEVELOPMENT**

<http://moud.gov.in>

# MUNICIPAL SOLID WASTE MANAGEMENT MANUAL

Central Public Health and Environmental  
Engineering Organisation (CPHEEO)

**IN COLLABORATION WITH**



**giz** Deutsche Gesellschaft  
für Internationale  
Zusammenarbeit (GIZ) GmbH

**German International Cooperation**

2016

In keeping with the advancements in this sector, updates as and when found necessary will be hosted in the Ministry website: <http://moud.gov.in/> and the reader is advised to refer to these also.

All rights reserved

No, portion of this document may be reproduced / printed for commercial purpose without the prior permission of the Ministry of Urban Development, Government of India

Designed under contract with GIZ by Aspire Design, New Delhi

**PART II:**  
Manual on  
Municipal Solid  
Waste Management



## AN INTRODUCTION TO THE MANUAL

The management of municipal solid waste in India has surfaced or continued to be a severe problem not only because of environmental and aesthetic concerns but also because of the enormous quantities generated every day. Even though only 31% of Indian population resides in urban areas, this population of 377 million (Census of India, 2011) generates a gigantic 1,43,449 metric tonnes per day of municipal solid waste, as per the Central Pollution Control Board (CPCB), 2014-15 and these figures increase every day with an increase in population. To further add to the problem, the total number of towns (statutory and census) in the country have also increased from 5,161 in 2001 to 7,936 in 2011, thus increasing the number of municipal waste generation by 2,775 within a decade.

The management of municipal solid waste is one of the main functions of all Urban Local Bodies (ULBs) in the country. All ULBs are required to meticulously plan, implement and monitor all systems of urban service delivery especially that of municipal solid waste. With limited financial resources, technical capacities and land availability, urban local bodies are constantly striving to meet this challenge.

With the launch of the flagship programme by the Government of India, Swachh Bharat Mission in 2014 that aims to provide basic infrastructural and service delivery with respect to sanitation facilities to every family, including toilets and adopting the scientific methods to collect, process and disposal of municipal solid waste. The mission focuses on quality and sustainability of the service provision as well as emphasising on the commitment on every stakeholder to bring about a visible change in society.

This manual on Municipal Solid Waste Management provides guidance to urban local bodies on the planning, design, implementation and monitoring of municipal solid waste management systems. Issues of environmental and financial sustainability of these systems are a critical consideration.

The manual clearly defines the planning process to be adopted by urban local bodies for preparing, revising and implementing Municipal Solid Waste Management Plans (MSWM Plans). The long term planning horizon of 25 years is further divided into short term plans to be prepared once every five years, with a mid-term review once every 2-3 years within this 5 year period, as per requirement. 'A seven step approach for MSWM Planning' is defined (Chapter 1), with special emphasis on community or stakeholder contribution and inter-departmental coordination at the local authority level to ensure implementation success. The Planning process suggests the adoption of the integrated solid waste management hierarchy for deciding on processing or technology solutions for municipal solid waste. Procedure for establishing the baseline of municipal solid waste management in urban local bodies is detailed

out. Ensuring financial viability of municipal solid waste management systems through revenue generation and encouraging Private Sector Participation (PSP) and Public Private Partnerships (PPPs) is suggested in this manual.

The MSWM Planning has to be supplemented with ‘Technical Aspects of MSW Segregation, Collection and Transportation’ that are addressed in detail (Chapter 2) in this manual. Processes for ensuring segregation at the household level in wet, dry and domestic hazardous waste, as suggested in the Solid Waste Management (SWM) Rules, 2016, are defined. Guidance mentioned under the SWM Rules, 2016 on waste collection and transportation systems is highlighted where relevant. Requirements for segregated secondary storage and transportation of segregated waste to appropriate processing and disposal facilities, sizing of systems for different scales of operation, norms for transfer stations, typical configurations of transfer stations, norms for street sweeping and corresponding resource allocation are provided in detail. Potential for involvement of the informal sector is explored, with a strong message that ULBs should consider the involvement of the informal sector after appropriately recognizing their services and with due focus on their livelihood and health.

MSWM Planning has to be strengthened by the ‘Technical Aspects of Processing and Treatment of MSW (Chapter 3)’: Urban Local Bodies, in the planning process, should make appropriate technology choices for waste management within the jurisdiction of the ULB, either independently or through the involvement of the private sector, with an aim to maximise resource conservation and efficiency and minimize health and environmental impacts. Waste minimization should be the primary focus of all community awareness programmes. Material recovery and recycling potential of municipal solid waste should be the first consideration in the management of generated waste. Where ever possible waste should be segregated into fractions promising viable recycling potential. Subsequently other forms of treatment and processing should be considered in accordance to the guidance given by the ISWM waste treatment and processing hierarchy. Guidance under the Solid Waste Management, Rules 2016 on waste processing and treatment technologies is highlighted where relevant. Technical specifications and design considerations for composting: windrow composting, aerated static pile, in-vessel composting decentralised composting, vermicomposting and yard waste composting, are given in detail. Waste to Energy technologies: incineration, biomethanation and RDF production and use are also covered in this manual. Specific issues to be considered while planning for and implementing these systems are defined and the scale at which these technologies are viable is clearly mentioned. Technologies under development: pyrolysis, gasification are discussed for guidance of urban local bodies. C&D waste management and guidance for urban local bodies is also included as part of this chapter.

The ISWM hierarchy clearly indicates that landfilling of municipal solid waste is the least preferred option for MSW management. However, given that the



municipal solid waste management system in the country has not yet reached a stage where landfilling can be avoided, sanitary landfill design guidelines and operational guidance is detailed out (Chapter 4). Rehabilitation of old dump sites is also addressed.

MSWM plan preparation considers operational and technological choices for an appropriate implementation route. This could be done either independently by the ULB or through private sector involvement or informal sector and with defined contracting and financing arrangements. Plan implementation should commence after the plan is approved by the Municipal Council and the buy-in from the community is ascertained.

Management aspects of municipal solid waste include statutory clearances like environmental clearances that are required for establishing municipal solid waste treatment, processing and disposal facilities. Pre-feasibility and feasibility studies may be required for ascertaining appropriate modes of treatment and processing at selected locations. Detailed Project Reports will need to be prepared to ensure detailed planning and financial viability of projects. Guidance on these aspects and on tendering, contracting and contract monitoring are also detailed out in Chapter 5.

Managing municipal solid waste is not easy, it requires regular monitoring of MSWM service provision by the ULB through basic or advanced Management Information Systems. All services provided by the ULB either through its own sources or through those outsourced to private entities, should be appropriately documented and monitored in order to ensure effective implementation and to identify issues that are to be addressed in the mid-term review of the MSWM plan and in subsequent short term plans (Chapter 6). Aspects of environmental monitoring, record keeping, training requirements for MSWM service provision are also addressed in this chapter.

Several waste types find their way into the municipal solid waste stream, which require special handling and disposal because of their quantity, concentration, physical and chemical characteristics or biological properties (special wastes). Many of these waste streams are also governed by specific Rules, viz. Plastic Waste Management Rules, 2016. Guidance on the ULBs' responsibilities for managing specific special waste streams namely, plastic waste, bio-medical waste, slaughter house waste, E-waste, waste tyres and lead battery waste are included in this manual (Chapter 7).

A compendium of good practises both national and international are included as Part III of the manual. All Rules and guidelines that are of relevance in the management of municipal solid waste for an ULB and are referred to in the different sections of Part II of the manual are included in the Part III of the Manual.



# TABLE OF CONTENTS

## CHAPTER 1: MUNICIPAL SOLID WASTE MANAGEMENT PLAN: STEP-WISE GUIDANCE

|   |          |
|---|----------|
| <b>1. Municipal Solid Waste Management Plan: Step-Wise Guidance</b>                       | <b>3</b> |
| 1.1 Requirements and Stipulations by the Rules  | 3        |
| 1.2 Guiding Principles for Municipal Solid Waste Management                               | 4        |
| 1.2.1 The Integrated Solid Waste Management System  | 4        |
| 1.2.2 Extended Producer Responsibility  | 6        |
| 1.2.3 Decentralised Waste Management Systems  | 6        |
| 1.2.4 Integration of the Informal Sector  | 7        |
| 1.3 Overview of Developing a Municipal Solid Waste Management Plan in an Urban Local Body | 8        |
| 1.4 Seven Step Approach for Municipal Solid Waste Management Planning                     | 14       |
| 1.4.1 Step 1: Policies, Programmes and Legal Framework                                    | 14       |
| 1.4.1.1 Identify National and State Policies or Strategies and their Goals                | 14       |
| 1.4.1.2 State level Municipal Solid Waste Management Strategies or Policies               | 16       |
| 1.4.1.3 Identify and Analyse Regional or District Solid Waste Management Plans            | 18       |
| 1.4.1.3.1 Objectives of Regional Solid Waste Management Plans                             | 19       |
| 1.4.1.3.2 Institutional Aspects of Regional Approaches                                    | 20       |
| 1.4.1.3.3 Implementation of Regional Municipal Solid Waste Management Plans               | 20       |
| 1.4.1.3.4 Land Allocation for Regional Municipal Solid Waste Projects                     | 21       |
| 1.4.1.3.5 Solid Waste Quantity and Tipping Fee  | 22       |
| 1.4.1.3.6 Collection and Transportation of Municipal Solid Waste                          | 22       |
| 1.4.1.4 Role of Central, State and Local Governments                                      | 24       |
| 1.4.1.4.1 Guidance on State and Urban Local Body Institutional Linkages                   | 34       |
| 1.4.2 Municipal Solid Waste Management Plan: Link to Service Level Benchmarks             | 34       |
| 1.4.3 Step 2: Assessment of Current Situation or Status and Gap Analysis                  | 36       |
| 1.4.3.1 Gap Analysis  | 37       |
| 1.4.3.2 Data Collection Methodology   | 41       |
| 1.4.3.2.1 Representative Data   | 41       |
| 1.4.3.3 Quantification and Composition of Waste   | 42       |
| 1.4.3.3.1 Waste Quantification  | 44       |
| 1.4.3.3.2 Determining Waste Composition   | 47       |
| 1.4.3.3.3 Physical Characteristics of Municipal Waste                                     | 48       |
| 1.4.4 Step 3: Stakeholder Consultation for Planning                                       | 50       |

|           |   |     |
|-----------|---|-----|
| 1.4.4.1   | Departments Involved in Municipal Solid Waste Management Planning (Internal Stakeholders)                       | 50  |
| 1.4.4.1.1 | Plan Preparation – Core Team  | 50  |
| 1.4.4.1.2 | Advisory Role   | 52  |
| 1.4.4.1.3 | External Stakeholders   | 52  |
| 1.4.4.2   | Defining the Goals and Objectives of the Municipal Solid Waste Management Plan                                  | 53  |
| 1.4.5     | Step 4: Preparation of Draft Municipal Solid Waste Management Plan  | 54  |
| 1.4.5.1   | Future Projections  | 54  |
| 1.4.5.1.1 | Forecasting Waste Generation  | 55  |
| 1.4.5.1.2 | Population Projection   | 55  |
| 1.4.5.2   | Per Capita Waste Generation   | 58  |
| 1.4.5.3   | Rules, Regulations and Municipal Bye-Laws   | 58  |
| 1.4.5.4   | Planning for an Institutional Structure (to bridge the gaps)  | 58  |
| 1.4.5.4.1 | Towns below 1 Lakh Population   | 59  |
| 1.4.5.4.2 | Cities between 1 and 2.5 Lakh Population  | 59  |
| 1.4.5.4.3 | Cities between 2.5 and 5 Lakh Population  | 60  |
| 1.4.5.4.4 | Cities between 5 and 20 Lakh Population   | 60  |
| 1.4.5.4.5 | Cities between 20 and 50 Lakh Population  | 60  |
| 1.4.5.4.6 | Cities above 50 Lakh Population   | 61  |
| 1.4.5.5   | Training and Capacity Building  | 61  |
| 1.4.5.6   | Financial Implementation Structure  | 63  |
| 1.4.5.6.1 | Overall Cost Assessment (Full Cost Assessment)  | 63  |
| 1.4.5.6.2 | Financial Viability of Municipal Solid Waste Management System  | 69  |
| 1.4.5.6.3 | Identification of Sources for Finance   | 69  |
| 1.4.5.6.4 | Deficit Management  | 86  |
| 1.4.5.7   | Analysis of Appropriate Public Private Partnership Contract Models  | 87  |
| 1.4.5.8   | Planning for Centralised and Decentralised Facilities   | 91  |
| 1.4.5.8.1 | Role of Decentralised Municipal Solid Waste Management Systems  | 91  |
| 1.4.5.8.2 | Management and Monitoring of Decentralised Municipal Solid Waste Facilities                                     | 94  |
| 1.4.5.9   | Arrangements for Informal Sector Integration  | 99  |
| 1.4.5.10  | Segregated Collection (Door-to-Door Collection, Street Sweeping and Drain Cleaning), Storage and Transportation | 102 |
| 1.4.5.11  | Identification of Land and Inclusion in City Master Plan or City Development Plan                               | 103 |
| 1.4.5.12  | Process Selection and Best Available Technology for Processing and Disposal                                     | 104 |
| 1.4.5.13  | Planning for Effective Community Participation through Information, Education and Communication                 | 113 |

|            |  |     |
|------------|--|-----|
| 1.4.5.13.1 | Communicating the Municipal Solid Waste Management Plan  | 114 |
| 1.4.6      | Step 5: Schedule for Implementation  | 119 |
| 1.4.7      | Step 6: Stakeholder Consultation for Municipal Solid Waste Management Plan Validation  | 120 |
| 1.4.8      | Step 7: Municipal Council Approval for Municipal Solid Waste Management Plan and Plan Implementation including Public Private Partnership  | 121 |
| 1.4.9      | Action Points for Awareness Generation through Information, Education, and Communication Activities for Municipal Solid Waste Management Plan Implementation by the Urban Local Body | 122 |

## **CHAPTER 2: TECHNICAL ASPECTS: SEGREGATION, COLLECTION AND TRANSPORTATION**

|           |   |            |
|-----------|---|------------|
| <b>2.</b> | <b>Technical Aspects: Segregation, Collection and Transportation</b>        | <b>127</b> |
| 2.1       | Waste Minimisation (At Source Reduction and Reuse)                          | 127        |
| 2.1.1     | Solid Waste Management Rules, 2016 - Requirements on Waste Minimisation     | 127        |
| 2.1.2     | Waste Minimisation in Integrated Solid Waste Management Hierarchy           | 127        |
| 2.1.3     | Need for and Benefits of Waste Minimisation                                 | 128        |
| 2.1.4     | Strategies for Waste Minimisation   | 128        |
| 2.1.4.1   | Waste Minimisation Strategies Requiring a National or State Level Directive | 128        |
| 2.1.4.2   | Waste Minimisation Initiatives Requiring Urban Local Bodies Support         | 131        |
| 2.1.5     | Developing a Waste Minimisation Programme in Urban Local Bodies             | 132        |
| 2.1.6     | Ensuring Feasibility of Waste Minimisation Programmes                       | 133        |
| 2.2       | Source Segregation  | 134        |
| 2.2.1     | Solid Waste Management Rules, 2016 - Requirements on Source Segregation     | 134        |
| 2.2.1.1   | Segregation of Municipal Solid Waste at Source                              | 137        |
| 2.2.1.2   | Storage of Municipal Solid Waste at Source                                  | 146        |
| 2.2.1.2.1 | Household-level Storage of Segregated Waste                                 | 146        |
| 2.2.1.2.2 | On-site Storage of Bulk Wastes  | 147        |
| 2.2.1.2.3 | Storage of Municipal Solid Waste in Public Places or Parks                  | 148        |
| 2.2.1.3   | Storage of Yard Waste or Garden Waste                                       | 148        |
| 2.2.1.4   | Storage and Processing of Special Wastes Including Domestic Hazardous Waste | 149        |

|            |   |     |
|------------|---|-----|
| 2.2.1.5    | Managing Industrial Wastes Generated Within Municipal Jurisdictions (Excluding Industrial Estates Within Municipal Areas) | 150 |
| 2.2.2      | Public Participation and Awareness  | 151 |
| 2.3        | Collection and Transportation   | 155 |
| 2.3.1      | Solid Waste Management Rules, 2016 - Requirements on Primary / Secondary Collection and Transportation                    | 155 |
| 2.3.2      | General Principles  | 156 |
| 2.3.3      | Primary Collection  | 160 |
| 2.3.3.1    | Location and Organisation of Primary Collection   | 160 |
| 2.3.4      | Vehicles and Equipment for Primary Collection   | 164 |
| 2.3.4.1    | Handcarts or Tricycles with Containers or Bins  | 164 |
| 2.3.4.2    | Tricycle with Hydraulic Tipping Containers  | 165 |
| 2.3.4.3    | Light Commercial Vehicles (Mini Trucks) with Hydraulic Tipping Containers   | 165 |
| 2.3.4.4    | Four-wheeled Mini Trucks with International Standard Bins   | 166 |
| 2.3.5      | Staffing and Equipment Requirements for Primary Collection  | 167 |
| 2.3.6      | Community Involvement in Primary Collection   | 169 |
| 2.3.7      | Role of the Informal Sector in Primary Waste Collection   | 170 |
| 2.3.8      | Secondary Collection and Transportation   | 175 |
| 2.3.8.1    | Concept of Bin-Less Area Or City  | 175 |
| 2.3.8.2    | Secondary Storage   | 176 |
| 2.3.8.3    | Vehicles and Equipment for Secondary Storage Collection   | 177 |
| 2.3.8.3.1  | Bins for Community Places on Public Roads and for Bulk Generators   | 177 |
| 2.3.8.3.2  | Four-wheeled Compactor Containers   | 177 |
| 2.3.9      | Criteria for Sizing Waste Storage Capacities  | 179 |
| 2.3.10     | Maintenance of Waste Storage Depots or Containers   | 179 |
| 2.3.10.1   | Secondary Segregation and Segregation at Transfer Stations  | 179 |
| 2.3.11     | Secondary Transportation  | 179 |
| 2.3.11.1   | Types of Vehicles and Equipment for Transportation  | 179 |
| 2.3.11.1.1 | Skip Truck (Dumper Placer)  | 180 |
| 2.3.11.1.2 | Refuse Collector without Compactor  | 181 |
| 2.3.11.1.3 | Rear Loading Compactor Trucks Used for Transportation   | 181 |
| 2.3.11.1.4 | Light Commercial Vehicle with Tipping Floor   | 182 |
| 2.3.12     | Waste Transportation Planning and Deployment of Equipment and Vehicles  | 182 |
| 2.3.12.1   | Management Information System for Waste Transportation  | 186 |
| 2.3.12.2   | Management of Contracts for Waste Collection and Transportation   | 189 |

|         |  |     |
|---------|--|-----|
| 2.4     | Street Cleaning  | 189 |
| 2.4.1   | Solid Waste Management Rules, 2016 -<br>Requirements on Street Cleaning  | 190 |
| 2.4.2   | Planning for Street Cleaning   | 190 |
| 2.4.2.1 | Street Classification and Street Cleaning Frequency  | 191 |
| 2.4.3   | Manual Street Cleaning   | 193 |
| 2.4.3.1 | Type of Street Cleaning Equipments   | 193 |
| 2.4.4   | Mechanised Street Cleaning   | 195 |
| 2.4.4.1 | Mechanical Broom Sweeper   | 195 |
| 2.4.4.2 | Regenerative Air Sweeper   | 196 |
| 2.4.4.3 | Vacuum Sweeper   | 197 |
| 2.4.4.4 | Financial Implications of Mechanised Street Cleaning   | 199 |
| 2.4.5   | Cleaning of Surface Drains   | 199 |
| 2.4.5.1 | Silt Management  | 200 |
| 2.4.6   | Transfer Stations  | 201 |
| 2.4.6.1 | Types of Transfer Stations   | 202 |
| 2.5     | Action Points for Awareness Generation through Information, Education, and<br>Communication Activities for Efficient Segregation, Collection and<br>Transportation | 206 |

### **CHAPTER 3: TECHNICAL ASPECTS OF PROCESSING AND TREATMENT OF MUNICIPAL SOLID WASTE**

|           |   |            |
|-----------|---|------------|
| <b>3.</b> | <b>Technical Aspects of Processing and Treatment of Municipal Solid Waste</b> | <b>209</b> |
| 3.1       | Recycling and Recovery  | 210        |
| 3.1.1     | Advantages of Recycling   | 210        |
| 3.1.2     | Assessment of Recyclables - Characterisation and Quantification               | 211        |
| 3.1.3     | Stages of Material Recovery   | 214        |
| 3.1.4     | Material Recovery Facility  | 216        |
| 3.1.4.1   | Types of Material Recovery Facility   | 216        |
| 3.1.4.1.1 | Unit Processes in Material Recovery Facility                                  | 219        |
| 3.1.5     | Need for Establishing Market Linkages and Extended Producer<br>Responsibility | 221        |
| 3.1.6     | Informal Sector Involvement in Recycling                                      | 222        |
| 3.1.7     | Recycling of Plastics   | 223        |
| 3.1.8     | Thermocol Recycling   | 223        |
| 3.1.9     | Recycling Paper and Board   | 224        |
| 3.1.10    | Recycling of Garden Waste or Yard Waste                                       | 227        |
| 3.1.11    | Construction and Demolition Waste   | 227        |
| 3.1.12    | E-Waste   | 228        |
| 3.1.13    | Greenhouse Gas Mitigation Potential from Recycling and Reuse                  | 228        |
| 3.2       | Composting  | 229        |

|           |  |     |
|-----------|--|-----|
| 3.2.1     | Solid Waste Management Rules, 2016: Guidance On Composting               | 229 |
| 3.2.2     | Composting in the Integrated Solid Waste Management Framework            | 231 |
| 3.2.3     | Benefits of Composting   | 231 |
| 3.2.4     | Need for Market Identification and Analysis                              | 232 |
| 3.2.4.1   | Constraints Faced by the Composting Sector in India                      | 234 |
| 3.2.5     | The Composting Process – Phases and Critical Parameters                  | 236 |
| 3.2.5.1   | Biological Processes   | 236 |
| 3.2.5.2   | Chemical Parameters  | 237 |
| 3.2.5.3   | Physical Processes   | 238 |
| 3.2.6     | Municipal Solid Waste Feedstock for Composting                           | 239 |
| 3.2.7     | Pre-Processing of Mixed Municipal Solid Waste                            | 240 |
| 3.2.8     | Composting Technologies  | 244 |
| 3.2.8.1   | Windrow Composting   | 244 |
| 3.2.8.2   | Key Performance Indicators for Windrow Compost Production                | 244 |
| 3.2.8.3   | Unit Operations in Windrow Composting                                    | 246 |
| 3.2.8.4   | Aerated Static Pile Composting   | 254 |
| 3.2.8.5   | In-Vessel Composting   | 256 |
| 3.2.8.6   | Decentralised Composting   | 258 |
| 3.2.8.6.1 | Bin Composting   | 260 |
| 3.2.8.6.2 | Box Composting   | 260 |
| 3.2.8.7   | Vermicomposting  | 265 |
| 3.2.9     | Yard Waste Composting  | 268 |
| 3.2.10    | Summary: Criteria for Selection of Composting Technologies               | 271 |
| 3.2.11    | Monitoring of Compost Plants   | 272 |
| 3.2.11.1  | Quality Parameters for Compost Production                                | 272 |
| 3.2.12    | Integration of the Informal Sector                                       | 274 |
| 3.2.13    | Human Resource Requirement   | 274 |
| 3.2.14    | Greenhouse Gas Emission Avoidance through Composting                     | 275 |
| 3.3       | Waste to Energy  | 276 |
| 3.3.1     | Solid Waste Management Rules, 2016: Guidance On Waste to Energy          | 276 |
| 3.3.2     | Waste to Energy (WtE) in the Integrated Solid Waste Management Hierarchy | 277 |
| 3.3.3     | Incineration   | 278 |
| 3.3.3.1   | Key Criteria for Municipal Solid Waste Incineration                      | 279 |
| 3.3.3.2   | Key Considerations for Incineration of Municipal Solid Waste             | 280 |
| 3.3.3.3   | Overview of the Incineration Process                                     | 281 |
| 3.3.3.4   | Siting of Incineration Plant   | 281 |
| 3.3.3.5   | Waste Reception and Handling   | 282 |
| 3.3.3.6   | Combustion and Steam Generation System                                   | 283 |
| 3.3.3.6.1 | Grate Incinerators   | 284 |
| 3.3.3.7   | Incinerator Air Feeding  | 286 |
| 3.3.3.8   | Flue Gas Recirculation   | 286 |



|           |   |     |
|-----------|---|-----|
| 3.3.3.9   | Residual Haulage and Disposal System  | 287 |
| 3.3.3.10  | Consumption of Raw Materials and Energy by<br>Incineration Plants           | 288 |
| 3.3.3.11  | Environmental Considerations  | 288 |
| 3.3.3.12  | Emission Reduction in Incinerators  | 288 |
| 3.3.3.13  | Monitoring Requirements   | 290 |
| 3.4       | Biomethanation  | 294 |
| 3.4.1     | Solid Waste Management Rules, 2016: Guidance On Biomethanation              | 295 |
| 3.4.2     | Merits of Biomethanation Process  | 296 |
| 3.4.3     | Applicability of Biomethanation   | 297 |
| 3.4.4     | General Process Involved in Biomethanation                                  | 297 |
| 3.4.5     | Operating Parameters for Biomethanation                                     | 299 |
| 3.4.6     | Types of Anaerobic Digesters in Use   | 301 |
| 3.4.7     | Utility of Biogas Produced in Biomethanation Plants                         | 307 |
| 3.4.7.1   | Local Gas Use   | 307 |
| 3.4.7.2   | Pipeline Injection  | 308 |
| 3.4.7.3   | Electricity Generation  | 308 |
| 3.4.7.4   | Purification of Biogas  | 308 |
| 3.5       | Refuse Derived Fuel   | 308 |
| 3.5.1     | Legal Framework for Refuse Derived Fuel Production and Utilisation          | 309 |
| 3.5.2     | Refuse Derived Fuel in Integrated Solid Waste Management Hierarchy          | 311 |
| 3.5.3     | General Composition of Refuse Derived Fuel in India                         | 311 |
| 3.5.4     | Refuse Derived Fuel Potential from Municipal Solid Waste                    | 312 |
| 3.5.5     | Utilisation of Refuse Derived Fuel  | 312 |
| 3.5.6     | Refuse Derived Fuel Production Process                                      | 313 |
| 3.5.7     | Potential Use of Refuse Derived Fuel in Industry                            | 314 |
| 3.5.7.1   | Co-processing in Cement Kilns or Coal based Power Plants                    | 315 |
| 3.5.7.1.1 | Technical Specification of Boilers  | 315 |
| 3.5.8     | Monitoring Requirements for Facilities Utilising Refuse Derived Fuel        | 319 |
| 3.5.9     | Greenhouse Gas Mitigation Potential from Refuse Derived<br>Fuel Utilisation | 319 |
| 3.6       | Technologies under Development  | 319 |
| 3.6.1     | Pyrolysis   | 320 |
| 3.6.1.1   | Feed Stock for Pyrolysis  | 321 |
| 3.6.1.2   | Municipal Solid Waste Pyrolysis   | 321 |
| 3.6.1.3   | Plasma Pyrolysis Vitrification  | 323 |
| 3.6.2     | Gasification  | 323 |
| 3.6.2.1   | Gasification of Municipal Solid Waste                                       | 323 |
| 3.6.2.2   | Types of Gasifiers for Municipal Solid Waste Treatment                      | 324 |
| 3.6.2.3   | Emerging Trends in Gasification   | 326 |
| 3.6.2.4   | Integrated Gasification with Power Generating Equipment                     | 328 |

|         |  |     |
|---------|--|-----|
| 3.6.2.5 | Challenges of Operating Gasification Plants  | 328 |
| 3.6.2.6 | Challenges of Utilising Pyrolysis and Gasification in the Indian Context   | 328 |
| 3.7     | Construction and Demolition Waste (C&D WASTE)  | 329 |
| 3.7.1   | Solid Waste Management Rules, 2016 – Requirements on Construction and Demolition Waste   | 329 |
| 3.7.2   | Construction and Demolition Waste Rules  | 329 |
| 3.7.3   | Responsibilities of Various Stakeholders for Construction and Demolition Waste Management  | 331 |
| 3.7.4   | Management of Construction and Demolition Waste  | 334 |
| 3.7.5   | Storage Collection Transportation and Disposal of Construction and Demolition Waste  | 335 |
| 3.7.5.1 | Site Selection for Storage, Collection, Processing and Recycling or Processing Facilities for Construction and Demolition Waste  | 335 |
| 3.7.5.2 | Benefits of Processing Construction and Demolition Waste   | 338 |
| 3.7.5.3 | Reuse and Recycling Potential  | 340 |
| 3.7.5.4 | Proposed use for Processed Construction and Demolition Waste   | 342 |
| 3.7.6   | Siting and Managing Construction and Demolition Recycling Plants   | 343 |
| 3.7.6.1 | Identification of Appropriate Land for Construction and Demolition Processing Facilities   | 343 |
| 3.7.6.2 | Siting Criteria for Storage and Processing Facilities  | 343 |
| 3.7.7   | Environmental Considerations   | 344 |
| 3.8     | Action Points for Awareness Generation through Information, Education, and Communication Activities for Technical Aspects of Processing and Treatment of Municipal Solid Waste | 347 |

## **CHAPTER 4: TECHNICAL ASPECTS: MUNICIPAL SANITARY LANDFILLS**

|           |  |            |
|-----------|--|------------|
| <b>4.</b> | <b>Technical Aspects: Municipal Sanitary Landfills</b>                   | <b>351</b> |
| 4.1       | Solid Waste Management Rules, 2016 - on Landfills                        | 351        |
| 4.2       | Environmental Impacts and its Minimisation                               | 359        |
| 4.3       | Types of Municipal Solid Waste to be Accepted at Landfills               | 359        |
| 4.4       | Essential Components of Municipal Sanitary Landfills                     | 360        |
| 4.5       | Planning and Design of a Landfill  | 361        |
| 4.5.1     | Site Selection   | 361        |
| 4.5.1.1   | Location Criteria  | 362        |
| 4.5.1.2   | Search Area  | 362        |
| 4.5.1.3   | Development of a List of Potential Sites                                 | 363        |
| 4.5.1.4   | Data Collection for Potential Sites                                      | 363        |
| 4.5.1.5   | Field Visit for Local Verification and Identification of Potential Sites | 365        |
| 4.5.1.6   | Selection of Best Ranked Sites   | 365        |

|            |  |     |
|------------|--|-----|
| 4.5.1.7    | Preliminary Environmental Impact Investigation             | 365 |
| 4.5.1.8    | Final Site Selection                                       | 366 |
| 4.5.1.9    | Site Investigation and Site Characterisation               | 366 |
| 4.5.2      | Sanitary Landfill Design                                   | 369 |
| 4.5.2.1    | Design Life  | 369 |
| 4.5.2.2    | Specific Waste Volume: Sanitary Landfill Capacity and Area | 369 |
| 4.5.2.3    | Sanitary Landfill Layout                                   | 370 |
| 4.5.2.4    | Technical Design Requirements                              | 372 |
| 4.5.2.5    | Base Sealing System  | 373 |
| 4.5.2.6    | Landfill Phasing   | 375 |
| 4.5.2.7    | Leachate Management  | 377 |
| 4.5.2.7.1  | Leachate Generation  | 377 |
| 4.5.2.7.2  | Leachate Collection  | 377 |
| 4.5.2.7.3  | Leachate Pond  | 381 |
| 4.5.2.7.4  | Leachate Treatment   | 382 |
| 4.5.2.8    | Waste Placement  | 384 |
| 4.5.2.9    | Surface Sealing System                                     | 384 |
| 4.5.2.10   | Infrastructure for Sanitary Landfill                       | 385 |
| 4.5.2.10.1 | Road Construction  | 385 |
| 4.5.2.10.2 | Equipment and Resources                                    | 385 |
| 4.5.2.10.3 | Waste Inspection Area or Emergency Area                    | 386 |
| 4.5.2.10.4 | Security and Fencing                                       | 386 |
| 4.5.2.10.5 | Tyre Cleaning Unit   | 386 |
| 4.5.2.10.6 | Sanitary Landfill Buildings                                | 386 |
| 4.5.3      | Construction of a Sanitary Landfill                        | 387 |
| 4.5.3.1    | Supervision of Construction Works                          | 387 |
| 4.5.3.2    | Quality Assurance  | 388 |
| 4.5.3.3    | Drainage Layer   | 393 |
| 4.5.3.4    | Leachate Collection System                                 | 393 |
| 4.5.3.5    | Slope Stability Aspects and Seismic Aspects                | 395 |
| 4.5.4      | Sanitary Landfill Operation                                | 396 |
| 4.5.4.1    | General Requirements                                       | 396 |
| 4.5.4.1.1  | Operation Manual   | 396 |
| 4.5.4.1.2  | Employee Assignments and Responsibilities                  | 396 |
| 4.5.4.1.3  | Staff Responsibilities and Qualifications                  | 397 |
| 4.5.4.1.4  | Hours of Opening and Operation                             | 398 |
| 4.5.4.1.5  | Site Notice Board  | 398 |
| 4.5.4.1.6  | Site Security  | 398 |
| 4.5.4.2    | Waste Reception and Control of Incoming Waste              | 399 |
| 4.5.4.2.1  | Execution of the Weighing Process                          | 399 |
| 4.5.4.3    | Waste Assignment   | 399 |
| 4.5.4.3.1  | Preparing of Filling Plans                                 | 400 |

|            |  |     |
|------------|--|-----|
| 4.5.4.4    | Filling and Compaction Procedure of Waste                              | 400 |
| 4.5.4.5    | Covering of Waste  | 402 |
| 4.5.4.5.1  | Daily Cover  | 402 |
| 4.5.4.5.2  | Intermediate Cover   | 402 |
| 4.5.4.5.3  | Temporary Surface Cover  | 402 |
| 4.5.4.5.4  | Covering during the Monsoon  | 402 |
| 4.5.4.6    | Final Cover (Surface Sealing System)                                   | 403 |
| 4.5.4.7    | Landfill Gas Management  | 403 |
| 4.5.4.7.1  | Controlled Passive Venting   | 403 |
| 4.5.4.7.2  | Controlled Active Collection and Treatment or Reuse                    | 404 |
| 4.5.4.8    | Sanitary Landfill Roads  | 405 |
| 4.5.4.8.1  | Road Construction  | 405 |
| 4.5.4.8.2  | Main and Temporary Roads   | 405 |
| 4.5.4.8.3  | Road Maintenance   | 406 |
| 4.5.4.9    | Storm Water Management   | 406 |
| 4.5.4.9.1  | Surface Water Collection   | 406 |
| 4.5.4.9.2  | Storm Water Retention Pond   | 407 |
| 4.5.4.9.3  | Maintenance of the Storm Water System                                  | 407 |
| 4.5.4.10   | Landfill Equipment   | 408 |
| 4.5.4.10.1 | Required Equipment   | 408 |
| 4.5.4.10.2 | Maintenance of Mobile Equipment  | 409 |
| 4.5.4.11   | Housekeeping on the Sanitary Landfill                                  | 409 |
| 4.5.4.11.1 | Health and Safety  | 409 |
| 4.5.4.11.2 | General Safety Measures  | 410 |
| 4.5.4.11.3 | Person Related Safety Measures   | 410 |
| 4.5.4.11.4 | First Aid  | 410 |
| 4.5.4.11.5 | Personnel Accidents  | 411 |
| 4.5.4.11.6 | Fire Prevention and Protection   | 411 |
| 4.5.4.12   | Environmental Monitoring   | 412 |
| 4.5.5      | Closure and Post Closure Plan  | 412 |
| 4.5.5.1    | Plantation at Landfill Site  | 412 |
| 4.5.6      | Considerations for Landfill Costing                                    | 412 |
| 4.5.7      | Existing Dumpsite Closure or Reclamation                               | 414 |
| 4.5.7.1    | Dumpsite Closure   | 414 |
| 4.5.7.2    | Dumpsite Reclamation   | 416 |
| 4.5.7.3    | Method for Dumpsite Reclamation  | 416 |
| 4.5.7.3.1  | Excavation   | 416 |
| 4.5.7.3.2  | Screening  | 417 |
| 4.5.7.4    | Expansion of Landfill Operations in Existing Waste<br>Dump or Landfill | 421 |
| 4.5.7.5    | Assessing Utility of the Closed or Covered Dumpsite –<br>Post 15 years | 422 |

|     |  |     |
|-----|--|-----|
| 4.6 | Action Points for Awareness Generation through Information, Education, and Communication Activities for Municipal Sanitary Landfills | 423 |
|-----|--|-----|

## **CHAPTER 5: MUNICIPAL SOLID WASTE MANAGEMENT PLAN IMPLEMENTATION**

|           |   |            |
|-----------|---|------------|
| <b>5.</b> | <b>Municipal Solid Waste Management Plan Implementation</b>   | <b>427</b> |
| 5.1       | Obtaining Statutory Clearances for Municipal Solid Waste Management Facilities  | 428        |
| 5.1.1     | Identification of Land for Municipal Solid Waste Management Processing, Treatment and Disposal – Preliminary Environmental Assessment | 429        |
| 5.1.2     | Environmental Impact Assessment Requirements for Municipal Solid Waste Management Facilities  | 430        |
| 5.1.2.1   | Roles and Responsibilities of Stakeholders Involved in Environmental Impact Assessment (EIA)  | 432        |
| 5.1.2.2   | Procedure for Environmental Impact Assessment (EIA) Clearance   | 432        |
| 5.2       | Preparation of Action Plans and Detailed Project Reports  | 435        |
| 5.2.1     | Action Plans for Municipal Solid Waste Management Service Provision   | 436        |
| 5.2.2     | Assessment of Suitability of Projects for Implementation through Public Private Partnership Mode                                      | 436        |
| 5.2.3     | Detailed Project Reports for Infrastructure Based Projects  | 440        |
| 5.3       | Considerations for Contracting a Municipal Solid Waste Management Service   | 443        |
| 5.3.1     | Contracting Arrangements for municipal Solid Waste Service Provision  | 445        |
| 5.4       | Tendering, Contract Management and Supervision  | 448        |
| 5.4.1     | Engaging With a Public Private Partner  | 449        |
| 5.4.2     | Tendering Process for Public Private Partnership Projects   | 450        |
| 5.4.2.1   | Single Stage Process  | 450        |
| 5.4.2.2   | Two Stage Process   | 451        |
| 5.4.3     | Request for Proposal (RFP) from ULBs  | 452        |
| 5.4.3.1   | Volume I: Instruction To Bidders (ITB)  | 452        |
| 5.4.3.2   | Volume II: Minimum Mandatory Technical and Performance Specifications or Project Information Memorandum                               | 453        |
| 5.4.3.3   | Volume III: Draft Concession Agreement  | 453        |
| 5.4.4     | Suggested Contents of Proposals from Bidders  | 456        |
| 5.4.5     | Cost Escalation   | 457        |
| 5.4.5.1   | Annual Escalation in General Costs  | 457        |
| 5.4.5.2   | Price Increase on Account of Increase in Diesel Or Staffing Costs   | 458        |
| 5.4.6     | Evaluation and Selection  | 459        |
| 5.4.7     | Contract Monitoring   | 460        |

|     |  |     |
|-----|--|-----|
| 5.5 | Operationalising the Financial Plan  | 462 |
| 5.6 | Action Points for Awareness Generation through Information, Education, and Communication Activities for Municipal Solid Waste Management Plan Implementation | 463 |

## **CHAPTER 6: MANAGEMENT ASPECTS: MONITORING MUNICIPAL SOLID WASTE MANAGEMENT SERVICE PROVISION**

|           |  |            |
|-----------|--|------------|
| <b>6.</b> | <b>Management Aspects: Monitoring Municipal Solid Waste Management Service Provision</b>   | <b>469</b> |
| 6.1       | Monitoring Municipal Solid Waste Management Service Provision  | 469        |
| 6.1.1     | Data Collection and Analysis for Monitoring  | 470        |
| 6.1.2     | Monitoring Achievement of Service Level Benchmarks   | 476        |
| 6.1.3     | Management Information System  | 477        |
| 6.1.3.1   | Record Keeping   | 483        |
| 6.2       | Operation and Maintenance Plan for Municipal Solid Waste Management Services   | 483        |
| 6.3       | Preventive Maintenance   | 485        |
| 6.3.1     | Benefits of Preventive Maintenance   | 486        |
| 6.4       | Complaint Redressal System   | 487        |
| 6.4.1     | Elements of a Complaint Redressal System   | 488        |
| 6.5       | Environmental and Occupational Health Monitoring of Municipal Solid Waste Treatment, Processing and Disposal Facilities                                    | 489        |
| 6.5.1     | Environmental Monitoring as per Solid Waste Management Rules, 2016   | 490        |
| 6.5.2     | Reporting Requirements   | 491        |
| 6.6       | Training Requirements for Monitoring Municipal Solid Waste Service Provision   | 492        |
| 6.7       | Action Points for Awareness Generation Through Information, Education, and Communication Activities for Monitoring Municipal Solid Waste Service Provision | 493        |

## **CHAPTER 7: MANAGEMENT OF SPECIAL WASTE INCLUDING DOMESTIC HAZARDOUS WASTE**

|           |  |            |
|-----------|--|------------|
| <b>7.</b> | <b>Management of Special Waste Including Domestic Hazardous Waste</b>  | <b>497</b> |
| 7.1       | Introduction to Special Waste Including Domestic Hazardous Waste   | 497        |
| 7.2       | Existing Rules for Management of Special Waste Including Domestic Hazardous Waste  | 497        |
| 7.3       | Special Waste Management including Domestic Hazardous Waste – Guidance from the Integrated Solid Waste Management (ISWM) Hierarchy | 500        |

|         |  |     |
|---------|--|-----|
| 7.4     | Plastic Waste  | 500 |
| 7.4.1   | Excerpts From the Plastic Waste Management Rules, 2016   | 500 |
| 7.4.2   | Composition of Plastics  | 504 |
| 7.4.3   | Plastic Waste Management   | 505 |
| 7.4.4   | Recycling of Plastic Wastes  | 506 |
| 7.4.4.1 | Steps Involved in the Recycling Process  | 507 |
| 7.4.5   | Sustainable Disposal of Plastic Waste  | 507 |
| 7.4.6   | Co-processing and Co-incineration of Plastic Waste as Alternative Fuel and Raw Material (AFR) in Cement Kilns  | 507 |
| 7.4.7   | Other Plastic Waste Disposal Options   | 509 |
| 7.4.7.1 | Use of Waste Plastic in Construction of Bituminous Roads   | 509 |
| 7.4.7.2 | Conversion of Plastic Waste into Liquid Fuel   | 510 |
| 7.4.7.3 | Incineration of Plastic Waste  | 511 |
| 7.5     | Bio-medical Waste  | 511 |
| 7.5.1   | Solid Waste Management Rules, 2016 - Requirements on Bio-Medical Waste   | 511 |
| 7.5.2   | Collection and Segregation of Waste in Health Care Establishments  | 512 |
| 7.6     | Slaughterhouse Waste   | 513 |
| 7.6.1   | Processing Slaughterhouse Waste  | 514 |
| 7.7     | Electric and Electronic Waste  | 518 |
| 7.7.1   | E-waste Management Rules, 2016   | 518 |
| 7.7.2   | Current status of E-waste Generation and its Management  | 519 |
| 7.7.3   | E-waste Categories   | 519 |
| 7.8     | Waste Tyres  | 521 |
| 7.8.1   | Storage of Used Tyres  | 522 |
| 7.8.2   | Reuse of Used Tyres  | 522 |
| 7.8.3   | Processing of Used Tyres   | 522 |
| 7.8.4   | Co-processing of Waste Tyres   | 522 |
| 7.9     | Lead Battery Waste   | 523 |
| 7.9.1   | The Batteries (Management & Handling) Rules, 2001  | 523 |
| 7.10    | Action Points for Awareness Generation Through Information, Education, and Communication Activities for Special Waste Including Domestic Hazardous Waste | 524 |

# LIST OF FIGURES AND TABLES

## FIGURES

|   |     |
|---|-----|
| Figure 1.1: Integrated Solid Waste Management System Hierarchy  | 5   |
| Figure 1.2: Seven-Step Approach for Developing a Plan*  | 8   |
| Figure 1.3: Step 1 in Municipal Solid Waste Management Plan   | 14  |
| Figure 1.4: Step 2 in Municipal Solid Waste Management Plan   | 37  |
| Figure 1.5: An Overview of Baseline Information Required for Strategic Planning                       | 37  |
| Figure 1.6: Considerations for Gap Analysis   | 38  |
| Figure 1.7: Characterisation of Municipal Solid Waste through Quartering Method                       | 49  |
| Figure 1.8: Step 3 in the Municipal Solid Waste Management Plan                                       | 51  |
| Figure 1.9: Step 4: Preparation of Draft Municipal Solid Waste Management Plan                        | 55  |
| Figure 1.10: Capacity Building Approaches for Different Stakeholders                                  | 63  |
| Figure 1.11: Elements of Full Cost Accounting   | 65  |
| Figure 1.12: Step 5: Schedule for Implementation  | 120 |
| Figure 1.13: Components of the Municipal Solid Waste Management Plan                                  | 120 |
| Figure 1.14: Components of a Short term Plan  | 121 |
| Figure 1.15: Step 6: Stakeholder Consultation for Municipal Solid Waste Management Plan Validation    | 121 |
| Figure 1.16: Step 7 in Municipal Solid Waste Management Plan  | 122 |
| Figure 2.1: Waste Minimisation in the Integrated Solid Waste Management Waste Hierarchy               | 127 |
| Figure 2.2: Developing a Waste Minimisation Programme   | 132 |
| Figure 2.3: Bins for Collection of Dry Waste and Wet Waste for Household                              | 143 |
| Figure 2.4: Typical Waste Collection Bins in Parks and along Walk-Ways                                | 144 |
| Figure 2.5: Flow Chart for Household Waste Collection, Transportation and Disposal                    | 158 |
| Figure 2.6: Flow Charts for Collection, Transportation and Disposal of Street Sweeping and Drain Silt | 159 |
| Figure 2.7: Flow Chart for Collection, Transportation and Disposal of Vegetable Market Waste          | 160 |
| Figure 2.8: Hand Carts with Bins  | 165 |
| Figure 2.9: Tricycle with Hydraulic Tipping Container   | 165 |
| Figure 2.10: Mini Truck with Hydraulic Container  | 166 |
| Figure 2.11: Waste Picker with Recyclable Material  | 172 |
| Figure 2.12: Synchronised Primary Collection and Secondary Storage                                    | 176 |
| Figure 2.13: Skip Truck (Dumper Placer Machines)  | 180 |
| Figure 2.14: Medium Size Compactor Truck  | 181 |
| Figure 2.15: Transfer of Waste from Secondary Collection Bins to Refuse Compactor                     | 182 |
| Figure 2.16: Fan-shaped and Bunched Filament Brooms (Delhi Model)                                     | 194 |



|   |     |
|---|-----|
| Figure 2.17: Mechanical Broom Sweeper   | 196 |
| Figure 2.18: Regenerative Air Sweeper   | 197 |
| Figure 2.19: Vacuum Sweeper and Vacuum Nozzle   | 197 |
| Figure 2.20: Self-propelled Road Sweeping Machine   | 198 |
| Figure 2.21: Truck Mounted with Pressure Water Jetting and Suction Machine                                    | 200 |
| Figure 2.22: Direct Transfer Station  | 202 |
| Figure 2.23: Stationary Compactor Transfer Station Design   | 203 |
| Figure 2.24: Typical Activities at the Transfer Station   | 203 |
| Figure 3.1: Integrated Solid Waste Management Hierarchy   | 209 |
| Figure 3.2: Recycling in Integrated Solid Waste Management Hierarchy  | 210 |
| Figure 3.3: Municipal Solid Waste Characterisation in India   | 212 |
| Figure 3.4: Stages of Material Recovery in Municipal Solid Waste Management Chain                             | 215 |
| Figure 3.5: Indicative Material Recovery Facility and Pre-sorting Facility for Mixed Waste                    | 217 |
| Figure 3.6: Indicative Material Recovery Facility and Pre-sorting Facility Dedicated to Dry Waste             | 218 |
| Figure 3.7: Indicative Material Recovery Facility and Pre-sorting Facility Dedicated to Wet Waste             | 218 |
| Figure 3.8: Composting in the Integrated Solid Waste Management Hierarchy                                     | 231 |
| Figure 3.9: Process of Aerobic Composting   | 236 |
| Figure 3.10: Pre-processing of Mixed Municipal Solid Waste  | 239 |
| Figure 3.11: Process Flowchart and Mass Balance for Aerobic Windrow Composting of 500 Tonnes Per Day of Waste | 245 |
| Figure 3.12: Windrow Sizing Calculations  | 247 |
| Figure 3.13: Arrangements and Turning of Windrows   | 249 |
| Figure 3.14: Squeeze Test to Estimate Moisture Content  | 250 |
| Figure 3.15: Unit Operations in Windrow Composting  | 252 |
| Figure 3.16: Aerated Static Pile  | 256 |
| Figure 3.17: Composting Process in In-Vessel Composting   | 257 |
| Figure 3.18: Bin Composting   | 260 |
| Figure 3.19: Cross Section of Typical 3 Tonne Composting Box  | 262 |
| Figure 3.20: Typical Cross Section of Composting Box  | 263 |
| Figure 3.21: Cross Section of Drainage Channels and Vertical Pipes  | 263 |
| Figure 3.22: WtE in the Integrated Solid Waste Management Hierarchy   | 277 |
| Figure 3.23: Typical Mass Burn Incinerator  | 282 |
| Figure 3.24: Grate Furnace and Heat Recovery Stages of a Municipal Waste Incineration Plant                   | 284 |
| Figure 3.25: Biomethanation Plant for 50 TPD Feed (Biodegradable MSW and Cattle Manure)                       | 306 |
| Figure 3.26: Refuse Derived Fuel in Integrated Solid Waste Management Hierarchy                               | 311 |

|  |     |
|--|-----|
| Figure 3.27: Refuse Derived Fuel Production Line (Pelletization)   | 313 |
| Figure 3.28: Municipal Solid Waste Pyrolysis   | 322 |
| Figure 3.29: Waste Gasification Plant  | 324 |
| Figure 4.1: Section of Typical Sanitary Landfill   | 360 |
| Figure 4.2: Typical Sanitary Landfill Layout with Facilities   | 371 |
| Figure 4.3: Base Liner   | 374 |
| Figure 4.4: a and b: Longitudinal Section Profile of Landfill Phasing (Not to Scale)                             | 375 |
| Figure 4.5: Liner Placement at the Edges of the Landfill   | 376 |
| Figure 4.6: Support of Leachate Pipes  | 378 |
| Figure 4.7: Placement of the High density Polyethylene Liner over the Clay Liner                                 | 379 |
| Figure 4.8: Placement of the Gravel Drainage Layer and Geotextile over the Clay Liner                            | 380 |
| Figure 4.9a: Leachate Collection Pipes Connected to a Sump (through the liner)                                   | 380 |
| Figure 4.9b: Leachate Collection Pipes Connected to a Sump (through a riser on the side slopes)                  | 380 |
| Figure 4.9c: Leachate Collection Pipes Connected to a Sump (sump within the footprint of the landfill)           | 381 |
| Figure 4.10: Sealed Leachate Pond with Two Basins  | 382 |
| Figure 4.11: Irrigation of Leachate on the Slopes of the Pond.   | 383 |
| Figure 4.12: Surface Liner System  | 385 |
| Figure 4.13: Sanitary Landfill under Construction  | 387 |
| Figure 4.14: Construction of Test Field  | 388 |
| Figure 4.15: Test Field with all Sealing Components  | 389 |
| Figure 4.16: Welding of HDPE Geomembrane   | 391 |
| Figure 4.17: Proof of welding seams  | 391 |
| Figure 4.18: Welding of Leachate Pipes   | 394 |
| Figure 4.19: Proper Holed Leachate Pipes   | 395 |
| Figure 4.20: Filling and Compaction Method   | 401 |
| Figure 4.21: Landfill Compactor  | 401 |
| Figure 4.22: Placement of Passive Vent   | 404 |
| Figure 4.23: Gas Recovery through Wells-Active   | 405 |
| Figure 4.24: Surface Water Drainage System in Completed Landfill   | 407 |
| Figure 4.25: Old Waste in New Landfill   | 415 |
| Figure 4.26: Closure of Old Waste Dump with Cover  | 415 |
| Figure 4.27: Expansion of Waste Dump   | 421 |
| Figure 4.28: Relocation of Waste   | 421 |
| Figure 4.29a: Horizontal Expansion (Option A – preferred)  | 421 |
| Figure 4.29b: Horizontal Expansion (Option B)  | 422 |
| Figure 5.1: Components of Municipal Solid Waste Management Plan  | 427 |
| Figure 5.2: Environmental Impact Assessment Clearance Requirements for Municipal Solid Waste Management Projects | 431 |

|   |     |
|---|-----|
| Figure 5.3: Steps for Conducting an Environment Impact Assessment (EIA)                                   | 434 |
| Figure 5.4: Hierarchy of Environmental Impact Mitigation Options  | 435 |
| Figure 5.5: Public Private Partnerships – Stages of Implementation.                                       | 437 |
| Figure 5.6: Process for Determining Suitability of Projects for Public Private Partnership Implementation | 440 |
| Figure 6.1: Minimum Data Requirement for MIS, GIS and GPS Systems   | 479 |
| Figure 7.1: Options for Plastic Waste Management  | 506 |
| Figure 7.2: Use of Plastic Waste in Construction of Bituminous Road                                       | 510 |

## TABLES

|  |     |
|--|-----|
| Table 1.1: Important Policy Landmarks and Initiatives by Government of India on Solid Waste Management   | 16  |
| Table 1.2: Role of Central, State and Local Governments in Municipal Solid Waste Management  | 24  |
| Table 1.3: Service Level Benchmarks for Solid Waste Management   | 36  |
| Table 1.4: Matrix for Collection of Baseline Information (including statutory requirements as per SWM Rules, 2016 and SLBs)                    | 39  |
| Table 1.5: Per-capita Waste Generation Rates from NEERI Study in 1996  | 44  |
| Table 1.6: Physical Composition of Municipal Solid Waste   | 44  |
| Table 1.7: Indicative Front-end Costs in a Typical Municipal Solid Waste Management System   | 66  |
| Table 1.8: Indicative Format for Assessing Capital Costs for Collection and Transportation System for Municipal Solid Waste Management         | 67  |
| Table 1.9: Indicative Format for Assessing Capital Costs for Establishing Processing and Disposal Systems for Municipal Solid Waste Management | 68  |
| Table 1.10: Indicative Format for Assessing Capital Costs for Collection and Transportation System for Municipal Solid Waste Management        | 68  |
| Table 1.10: Indicative Format for Assessing Capital Costs for Collection and Transportation System for Municipal Solid Waste Management        | 69  |
| Table 1.11: Format for Assessing Financial Deficits for Provision of Municipal Solid Waste Management Services                                 | 70  |
| Table 1.12: Mechanisms for Recovery of Municipal Solid Waste Management User Charges   | 80  |
| Table 1.13: Format for Assessing the Gap and Bridging the Financial Deficit for Municipal Solid Waste Management Services                      | 87  |
| Table 1.14: Key Characteristics of Contracts in Municipal Solid Waste Sector   | 88  |
| Table 1.15: Contracting Models & Private Sector Responsibilities   | 90  |
| Table 1.15: Contracting Models and Private Sector Responsibilities [contd.]  | 91  |
| Table 1.16: Management Models for Decentralised Waste Management   | 96  |
| Table 1.17: Criteria for Identifying Suitable Land for Sanitary Landfill Sites   | 104 |

|  |     |
|--|-----|
| Table 1.18: Indicative Criteria for Selection of Appropriate Technology or Combination of Technologies   | 106 |
| Table 1.19: Stages of Municipal Solid Waste Management Plan Implementation – Objectives and Target Audience  | 116 |
| Table 2.1: Indicative List for Segregation of Household Wastes,  | 140 |
| Table 2.2: Elements of Primary Waste Collection System   | 167 |
| Table 2.3: Estimates for Deployment of Vehicles and Manpower for Primary Collection  | 169 |
| Table 2.4: Municipal Solid Waste Management Plan for Municipal Councils and A, B, C Class Cities,  | 183 |
| Table 2.5: Municipal Solid Waste Management Plan for Municipal Corporations  | 184 |
| Table 2.6: Street Sweeping Norms for Small towns or Small Cities or Mega Cities  | 191 |
| Table 2.7: Typical Classification of Streets and Frequency of Sweeping   | 192 |
| Table 3.1: Important Recycling Material: Recycling Potential and Special Conditions  | 212 |
| Table 3.2: Different Processes or Stages and Equipment Employed in a Material Recovery Facility  | 220 |
| Table 3.3: Pre-processing: Sorting of Mixed Municipal Solid Waste Feedstock  | 242 |
| Table 3.4: Vermicomposting- Problems, Possible Causes and Solutions  | 268 |
| Table 3.5: Yard Composting-Problems and Solutions  | 270 |
| Table 3.6: Summary of Different Composting Technologies  | 271 |
| Table 3.7: Compost Quality Standards as per Solid Waste Management Rules, 2016; Fertiliser Control Order, 2009; and Fertiliser Control Order, 2013 | 273 |
| Table 3.8: Vermicompost Standards as per Fertilizer Control Order, 2009  | 274 |
| Table 3.9: Indicative Staff Requirement for a 300 TPD Compost Plant (Windrow)  | 275 |
| Table 3.10: Air Emission Control Technologies  | 289 |
| Table 3.11: The Stack Emission Standards for Treatment and Utilisation of Municipal Solid Waste Using Incinerator or Thermal Technologies          | 291 |
| Table 3.12: Emission Norms for Incineration of Municipal Solid Waste as per European Union Directive   | 292 |
| Table 3.13: Indicative Net Calorific Value of Refuse Derived Fuel vs. Coal   | 312 |
| Table 3.14: Thermal Capacity of Different Gasifier Design  | 326 |
| Table 3.15: C&D Wastes and Their Reuse Potential   | 341 |
| Table 3.16: Potential Environmental Issues with Siting and Managing a Construction and Demolition Recycling Facility                               | 345 |
| Table 3.17: Ambient Air Quality at the Processing or Recycling Site and in the Vicinity  | 346 |
| Table 4.1: Criteria for Identifying Suitable Land for Sanitary Landfill Sites  | 362 |
| Table 4.2: Rough Guidance for Sanitary Landfill Sizes  | 363 |
| Table 4.3: Data Collection and Sources   | 363 |
| Table 4.4: Minimum Slopes Inside the Sanitary Landfill   | 374 |
| Table 4.5: Provisional Staffing Table  | 396 |
| Table 4.6: Staff Qualification   | 397 |



## ABBREVIATIONS

|       |  |
|-------|--|
| ABC   | Asphalt, Brick and Concrete                                    |
| ABS   | Area Based System  |
| AD    | Anaerobic Digestion  |
| ADB   | Asian Development Bank   |
| ADDA  | Asansol Durgapur Development Authority                         |
| ADS   | Air Density Separator / De-stoner                              |
| AFR   | Alternative Fuels and Raw material                             |
| ALM   | Advanced Locality Management                                   |
| AMC   | Asansol Municipal Corporation                                  |
| APITC | Andhra Pradesh Industrial & Technical Consultancy Organization |
| APPCB | Andhra Pradesh Pollution Control Board                         |
| ASR   | Auto Shredder Residue  |
| ASTM  | American Society for Testing and Materials                     |
| BARC  | Bhabha Atomic Research Centre                                  |
| BBMP  | Bruhat Bangalore Mahanagara Palika                             |
| BFB   | Bubbling Fluidized Bed   |
| BIS   | Bureau of Indian Standards                                     |
| BOD   | Biochemical Oxygen Demand                                      |
| BOO   | Build Own Operate  |
| BOOT  | Build Own Operate and Transfer                                 |
| BOT   | Build Operate Transfer   |
| C&D   | Construction & Demolition                                      |
| CA    | Concession Agreement   |
| CAA   | Constitutional Amendment Act                                   |
| CBG   | Compressed Biogas  |
| CBOs  | Community Based Organizations                                  |
| CCF   | Clean City Foundation  |
| CE    | Combustion Efficiency  |
| CEO   | Chief Executive Officer  |
| CFB   | Circulating Fluidized Bed                                      |
| CFL   | Compact Fluorescent Lamps                                      |
| CIPET | Central Institute of Plastics Engineering and Technology       |
| CMA   | Commissionerate of Municipal Administration                    |
| CMWMF | Common Municipal Waste Management Facilities                   |
| CNG   | Compressed Natural Gas   |
| CoC   | Cochin Municipal Corporation                                   |

|               |  |
|---------------|--|
| <b>COD</b>    | Chemical Oxygen Demand   |
| <b>CoP</b>    | Corporation of Panaji  |
| <b>CPCB</b>   | Central Pollution Control Board                                  |
| <b>CPHEEO</b> | Central Public Health and Environmental Engineering Organization |
| <b>CPU</b>    | Carcass Processing Unit  |
| <b>CPWD</b>   | Central Public Works Department                                  |
| <b>CREDAI</b> | Confederation of Real Estate Developers' Associations of India   |
| <b>CRRRI</b>  | Central Road Research Institute                                  |
| <b>CSI</b>    | City Sanitary Inspector  |
| <b>CSP</b>    | City Sanitation Plan   |
| <b>CSTR</b>   | Continuously Stirred Tank Reactor                                |
| <b>D2D</b>    | Door-to-door   |
| <b>DBFOT</b>  | Design, Build, Finance, Operate and Transfer                     |
| <b>DBO</b>    | Design-Build-Operate   |
| <b>DBOOT</b>  | Design-Build-Own-Operate and Transfer                            |
| <b>DC</b>     | Drain Cleaning   |
| <b>DEA</b>    | Department of Economic Affairs                                   |
| <b>DMA</b>    | Directorate of Municipal Administration                          |
| <b>DMC</b>    | Durgapur Municipal Corporation                                   |
| <b>DPR</b>    | Detailed Project Report  |
| <b>DRANCO</b> | Dry Anaerobic Composting   |
| <b>DRE</b>    | Destruction Removal Efficiency                                   |
| <b>DWCC</b>   | Dry Waste Collection Centres                                     |
| <b>EAC</b>    | Expert Appraisal Committee                                       |
| <b>EDMC</b>   | East Delhi Municipal Corporation                                 |
| <b>EIA</b>    | Environment Impact Assessment                                    |
| <b>EM</b>     | Effective Micro Organisms  |
| <b>EMP</b>    | Environmental Management Plan                                    |
| <b>EoI</b>    | Expression of Interest   |
| <b>EPF</b>    | Employment Provident Fund  |
| <b>EPR</b>    | Extended Producer Responsibility                                 |
| <b>EPS</b>    | Expanded Polystyrene   |
| <b>EPTRI</b>  | Environment Protection Training and Research Institute           |
| <b>ESI</b>    | Employees' State Insurance                                       |
| <b>ESP</b>    | Electrostatic Precipitator                                       |
| <b>ETP</b>    | Effluent Treatment Plant   |
| <b>EU</b>     | European Union   |
| <b>FAQ</b>    | Frequently Asked Question  |
| <b>FCA</b>    | Full Cost Accounting   |
| <b>FCO</b>    | Fertilizer Control Order   |
| <b>FGT</b>    | Flue Gas Treatment   |

|                  |   |
|------------------|---|
| <b>FRP</b>       | Fiber Reinforced Plastic                                |
| <b>GCL</b>       | Geo Synthetic Clay Liner                                |
| <b>GDP</b>       | Gross Domestic Product                                  |
| <b>GHG</b>       | Green House Gas   |
| <b>GIS</b>       | Geographic Information System                           |
| <b>GNCTD</b>     | Government of National Capital Territory of Delhi       |
| <b>GoI</b>       | Government of India                                     |
| <b>GPRA</b>      | General Pool Residential Accommodation                  |
| <b>GPRS</b>      | General Packet Radio Identification                     |
| <b>GPS</b>       | Global Positioning System                               |
| <b>GSB</b>       | Granular Sub Base                                       |
| <b>GSI</b>       | Geologic Survey of India                                |
| <b>HAPs</b>      | Hazardous Air Pollutants                                |
| <b>HDPE</b>      | High-Density Polyethylene                               |
| <b>HH</b>        | Households  |
| <b>HRT</b>       | Hydraulic Retention Time                                |
| <b>HUDCO</b>     | Housing and Urban Development Corporation               |
| <b>IARI</b>      | Indian Agricultural Research Institute                  |
| <b>IC</b>        | Internal Combustion                                     |
| <b>ICICI</b>     | Industrial Credit and Investment Corporation of India   |
| <b>ICT</b>       | Information and Communication Technology                |
| <b>IDBI</b>      | Industrial Development Bank of India                    |
| <b>IDFC</b>      | Infrastructure Development Finance Company              |
| <b>IEC</b>       | Information, Education and Communication                |
| <b>IEISL</b>     | IL&FS Environmental Infrastructure and Services Limited |
| <b>IFCI</b>      | Industrial Finance Corporation of India                 |
| <b>IGCC</b>      | Integrated Gasification Combined Cycle                  |
| <b>IL&amp;FS</b> | Infrastructure Leasing and Financial Services           |
| <b>ILO</b>       | International Labour Organization                       |
| <b>IMD</b>       | Indian Meteorological Department                        |
| <b>IPNM</b>      | Integrated Plant Nutrient Management                    |
| <b>IREDA</b>     | Indian Renewable Energy Development Agency              |
| <b>IS</b>        | Indian Standards  |
| <b>ISWM</b>      | Integrated Solid Waste Management                       |
| <b>ITB</b>       | Instruction to Bidders                                  |
| <b>JBIC</b>      | Japan Bank for International Cooperation                |
| <b>JMC</b>       | Jabalpur Municipal Corporation                          |
| <b>JnNURM</b>    | Jawaharlal Nehru National Urban Renewal Mission         |
| <b>KfW</b>       | Kreditanstalt für Wiederaufbau                          |
| <b>KKPKP</b>     | Kagad Kach Patra Kashtakari Panchayat                   |
| <b>KKPNSPS</b>   | Kagad Kach Patra Sahkari Patra Sansthan                 |



|                      |   |
|----------------------|---|
| <b>KMC</b>           | Kolkata Municipal Corporation   |
| <b>KPI</b>           | Key Performance Indicators  |
| <b>LCD</b>           | Liquid Crystal Display  |
| <b>LCS</b>           | Leachate Collection System  |
| <b>LCV</b>           | Light Commercial Vehicle  |
| <b>LDO</b>           | Light Diesel Oil  |
| <b>LDPE</b>          | Low-density polyethylene  |
| <b>LED</b>           | Light Emitting Diode  |
| <b>LEL</b>           | Lower Explosive Limit   |
| <b>LIC</b>           | Life Insurance Corporation of India                                   |
| <b>LoI</b>           | Letter of Intent  |
| <b>LPG</b>           | Liquid Petroleum Gas  |
| <b>M&amp;E</b>       | Monitoring & Evaluation   |
| <b>MCD</b>           | Municipal Corporation of Delhi  |
| <b>MCGM</b>          | Municipal Corporation of Greater Mumbai                               |
| <b>MIS</b>           | Management Information System   |
| <b>MMRDA</b>         | Maharashtra Metropolitan Regional Development Authority               |
| <b>MNRE</b>          | Ministry of New and Renewable Energy                                  |
| <b>MoA</b>           | Ministry of Agriculture   |
| <b>MoEFCC</b>        | Ministry of Environment and Forests & Climate Change                  |
| <b>MoUD</b>          | Ministry of Urban Development   |
| <b>MPPCB</b>         | Madhya Pradesh Pollution Control Board                                |
| <b>MRF</b>           | Material Recovery Facility  |
| <b>MSW (M&amp;H)</b> | Municipal Solid Waste (Management and Handling)                       |
| <b>MSWMP</b>         | Municipal Solid Waste Management Plan                                 |
| <b>NABARD</b>        | National Bank for Agriculture and Rural Development                   |
| <b>NABL</b>          | National Accreditation Board for Testing and Calibration Laboratories |
| <b>NAC</b>           | Notified Area Committee   |
| <b>NAPCC</b>         | National Action Plan on Climate Change                                |
| <b>NBCC</b>          | National Buildings Construction Company                               |
| <b>NCC</b>           | National Cadet Corps  |
| <b>NCRPB</b>         | National Capital Region Planning Board                                |
| <b>NCV</b>           | Net Calorific Value   |
| <b>NEERI</b>         | National Environmental Engineering Research Institute                 |
| <b>NGO</b>           | Non- Government Organization  |
| <b>NGRI</b>          | National Geophysical Research Institute                               |
| <b>NIMBY</b>         | Not in My Backyard  |
| <b>NMC</b>           | Nashik Municipal Corporation  |
| <b>NMMC</b>          | Navi Mumbai Municipal Corporation                                     |
| <b>NMSH</b>          | National Mission on Sustainable Habitat                               |
| <b>NTPC</b>          | National Thermal Power Corporation                                    |

|       |  |
|-------|--|
| NUSP  | National Urban Sanitation Policy                 |
| O&M   | Operation and Maintenance                        |
| OEM   | Original Equipment Manufacturer                  |
| OHSAS | Occupational Health and Safety Assessment System |
| OMC   | Optimum Oxygen Content                           |
| OWC   | Organic Waste Converters                         |
| PBG   | Performance Bank Guarantee                       |
| PBVS  | Parisar Bhagini Vikas Sangha                     |
| PCC   | Pollution Control Committee                      |
| PCMC  | Pimpri Chinchwad Municipal Corporation           |
| PFDF  | Pooled Finance Development Fund                  |
| PIL   | Public Interest Litigation                       |
| PIM   | Project Information Memorandum                   |
| PNG   | Piped Natural Gas                                |
| PPE   | Personal Protection Equipment                    |
| PPP   | Public Private Partnership                       |
| PROM  | Phosphate Rich Organic Manure                    |
| PS    | Polystyrene                                      |
| PSA   | Pressure Swing Adsorption                        |
| PSP   | Private Sector Participation                     |
| PTO   | Power Take-Off                                   |
| PUF   | Polyurethane Foam                                |
| PVC   | Polyvinyl Chloride                               |
| PVP   | Parisar Vikas Programme                          |
| RA    | Recycled Aggregates                              |
| RCA   | Recycled Concrete Aggregates                     |
| RCC   | Reinforced Cement Concrete                       |
| RDF   | Refuse Derived Fuel                              |
| RFID  | Radio Frequency Identification                   |
| RFP   | Request for Proposal                             |
| RFQ   | Request for Qualification                        |
| RMC   | Ready Mix Concrete                               |
| RPM   | Respirable Particulate Matter                    |
| RSPM  | Respirable Suspended Particulate Matter          |
| RWA   | Resident Welfare Association                     |
| S.I.  | Sanitary Inspector                               |
| S.O   | Sanitary Officer                                 |
| S.S.  | Sanitary Supervisor                              |
| S.S.I | Sanitary Sub-Inspector                           |
| SC&T  | Street Collection & Transportation               |
| SCR   | Selective Catalytic Reduction                    |

|                |   |
|----------------|---|
| <b>SEAC</b>    | State Expert Appraisal Committee                                    |
| <b>SEHB</b>    | Shimla Environment Heritage Conservation and Beautification Society |
| <b>SEIAA</b>   | State Environment Impact Assessment Authority                       |
| <b>SHGs</b>    | Self Help Groups  |
| <b>SLB</b>     | Service Level Benchmark   |
| <b>SLF</b>     | Sanitary Landfill Facility  |
| <b>SMC</b>     | Saharanpur Municipal Corporation                                    |
| <b>SMS</b>     | Stree Mukti Sanghathana   |
| <b>SNCR</b>    | Selective Non-catalytic Reduction                                   |
| <b>SOP</b>     | Standard Operating Procedure  |
| <b>SPCB</b>    | State Pollution Control Board                                       |
| <b>SPFE</b>    | State Pooled Finance Entities                                       |
| <b>SPI</b>     | Society of the Plastics Industry                                    |
| <b>SS</b>      | Street Sweeping   |
| <b>SSD</b>     | Saturated Surface Dry   |
| <b>SSS</b>     | State Sanitation Strategy   |
| <b>STP</b>     | Sewage Treatment Plant  |
| <b>SWaCH</b>   | Solid Waste Collection & Handling                                   |
| <b>TCLP</b>    | Toxicity Characteristic Leaching Procedure                          |
| <b>TEAM</b>    | TERI Enhanced Acidification and Methanation                         |
| <b>TERI</b>    | The Energy & Resources Institute                                    |
| <b>TOR</b>     | Terms of Reference  |
| <b>TPD</b>     | Tonnes per Day  |
| <b>TSDF</b>    | Treatment, Storage & Disposal Facility                              |
| <b>UAFP</b>    | Up-flow Anaerobic Filter Process                                    |
| <b>UASB</b>    | Up-flow Anaerobic Sludge Blanket                                    |
| <b>UDD</b>     | Urban Development Department  |
| <b>UIDSSMT</b> | Urban Infrastructure Development Scheme for Small & Medium Towns    |
| <b>UIG</b>     | Urban Infrastructure and Governance                                 |
| <b>ULB</b>     | Urban Local Body  |
| <b>UNDP</b>    | United Nations Development Programme                                |
| <b>UNFCCC</b>  | United Nations Framework Convention on Climate Change               |
| <b>UV</b>      | Ultra Violet  |
| <b>VAT</b>     | Value Added Tax   |
| <b>WEEE</b>    | Waste of Electrical and Electronic Equipment                        |
| <b>WMC</b>     | Warangal Municipal Corporation                                      |
| <b>WOW</b>     | Waste Out of Wealth   |
| <b>WPLF</b>    | Waste Processing & Landfill   |
| <b>WTE</b>     | Waste to Energy   |

## CHEMICALS AND COMPOUNDS

|                                  |                                       |
|----------------------------------|---------------------------------------|
| As                               | Arsenic                               |
| C                                | Carbon                                |
| C <sub>6</sub> H <sub>5</sub> OH | Phenol / Carbolic Acid                |
| Cd                               | Cadmium                               |
| CH <sub>4</sub>                  | Methane                               |
| Cl                               | Chloride                              |
| CN                               | Cyanide                               |
| CO                               | Carbon monoxide                       |
| Co                               | Cobalt                                |
| CO <sub>2</sub>                  | Carbon dioxide                        |
| Cr                               | Chromium                              |
| Cu                               | Copper                                |
| F                                | Fluoride                              |
| H <sub>2</sub> S                 | Hydrogen sulphide                     |
| HCl                              | Hydrochloric acid                     |
| HF                               | Hydrogen fluoride                     |
| Hg                               | Mercury                               |
| K                                | Potassium                             |
| K <sub>2</sub> O                 | Potassium Oxide                       |
| KF                               | Potassium fluoride                    |
| Li-ion                           | Lithium-ion                           |
| LSHS                             | Low Sulphur Heavy Stock               |
| Mn                               | Manganese                             |
| MS                               | Multi station                         |
| N                                | Nitrogen                              |
| Ni                               | Nickel                                |
| NO                               | Nitrogen monoxide                     |
| NO <sub>x</sub>                  | Nitrogen oxides                       |
| P                                | Potassium                             |
| P <sub>2</sub> O <sub>5</sub>    | Phosphorus pentoxide                  |
| PAHs                             | Polychlorinated Aromatic Hydrocarbons |
| Pb                               | Lead                                  |
| PCBs                             | Polychlorinated biphenyl              |
| PCDD                             | Polychlorinated di-benzodioxins       |
| PCDF                             | Polychlorinated di-benzofurans        |
| PET                              | Polyethylene terephthalate            |

|                       |                                     |
|-----------------------|-------------------------------------|
| <b>pH</b>             | Acidity or alkalinity of a solution |
| <b>PM</b>             | Particulate Matter                  |
| <b>POP</b>            | Persistent Organic Pollutants       |
| <b>PP</b>             | Polypropylene                       |
| <b>Sb</b>             | Antimony                            |
| <b>Sn</b>             | Tin                                 |
| <b>SO<sub>2</sub></b> | Sulphur oxide                       |
| <b>SO<sub>4</sub></b> | Sulphate                            |
| <b>Th</b>             | Thorium                             |
| <b>Tl</b>             | Thallium                            |
| <b>TOC</b>            | Total organic carbon                |
| <b>TPH</b>            | Tonnes per Hour                     |
| <b>V</b>              | Vanadium                            |
| <b>VOC</b>            | Volatile Organic Compound           |
| <b>Zn</b>             | Zinc                                |

## METRIC CONVERSION TABLE

### AREA

|       |                  |  |
|-------|------------------|--|
| ha    | Hectares         | 1 hectare = 2.47 acres or 1,07,639 square feet (sq ft) |
| sq.km | Square kilometre | 1 sq. km = 0.386102 square mile (sq mi)                |

### LENGTH

|         |            |                     |
|---------|------------|---------------------|
| km      | Kilometre  | 1 km = 1000 m       |
| m       | Meter      | 1 m = 1000 cm       |
| cm      | Centimetre | 1 cm = 1000 mm      |
| mm      | Millimetre | 1 mm = 1000 $\mu$ m |
| $\mu$ m | Micrometre |                     |

### VOLUME

|                        |   |  |
|------------------------|---|--|
| l                      | Litre   | 1 l = 0.001 m m <sup>3</sup>                         |
| m <sup>3</sup> or cu.m | Cubic metre                                     | 1 m <sup>3</sup> or cu.m = 10,00,000 cm <sup>3</sup> |
| cm <sup>3</sup>        | Cubic centimetre                                | 1 cm <sup>3</sup> = 1e+21 Nm <sup>3</sup>            |
| Nm <sup>3</sup>        | Normal cubic metres                             |  |
| TEQ / Nm <sup>3</sup>  | Dioxin toxic equivalent per normal cubic metres |  |
| KLD                    | Kilolitre per day                               |  |

### MASS

|         |                        |                         |
|---------|------------------------|-------------------------|
| MT or T | Metric tonne or tonne  | 1 MT or T = 1000 kg     |
| kg      | Kilogram               | 1 kg = 1000 g           |
| g       | Gram                   | 1 g = 10,00,000 $\mu$ g |
| $\mu$ g | Microgram              |                         |
| gsm     | Grams per square metre |                         |

### ENERGY

|      |              |                   |
|------|--------------|-------------------|
| MW   | Megawatt     | 1 MW = 1000 KW    |
| kW   | Kilowatt     | 1 KW = 1000 W     |
| kcal | Kilocalories | 1 kcal = 1000 cal |

### TEMPERATURE

|    |         |                              |
|----|---------|------------------------------|
| °C | Celsius | 1°C = 33.800 Fahrenheit (°F) |
|----|---------|------------------------------|

## CURRENCY CONVERSION CHART

| <b>INDIAN NUMBERING SYSTEM</b>         | <b>INTERNATIONAL NUMBERING SYSTEM</b>  |
|--|--|
| One lakh<br><b>1,00,000</b>            | One hundred thousand<br><b>100,000</b> |
| Ten lakhs<br><b>10,00,000</b>          | One million<br><b>1,000,000</b>        |
| One crore<br><b>1,00,00,000</b>        | Ten millions<br><b>10,000,000</b>      |
| Ten crores<br><b>10,00,00,000</b>      | Hundred millions<br><b>100,000,000</b> |
| Hundred crores<br><b>100,00,00,000</b> | One billion<br><b>1,000,000,000</b>    |





1

# **Municipal Solid Waste Plan: Step-Wise Guidance**

## IN THIS SECTION

|     |   |    |
|-----|---|----|
| 1.1 | Requirements and stipulations by the Rules  | 3  |
| 1.2 | Guiding Principles for Municipal Solid Waste Management                               | 4  |
| 1.3 | Overview of Developing a Municipal Solid Waste Management Plan in an Urban Local Body | 8  |
| 1.4 | Seven Step Approach for Municipal Solid Waste Management Planning                     | 14 |

# 1. MUNICIPAL SOLID WASTE MANAGEMENT PLAN: STEP-WISE GUIDANCE

As many of the municipal authorities are still to develop in-house capabilities to independently govern their solid waste, the central and state governments continue to play a crucial role by formulating policies, programmes, and regulations and by providing technical and financial assistance for infrastructure development including management of municipal solid waste (MSW) in urban areas. Although municipal solid waste management (MSWM) is an essential service and a mandatory function of municipal authorities across the country, it is still being managed in an unplanned manner, giving rise to environmental degradation and serious health problems especially for women and children. This clearly underlines the need for preparing a strategic and detailed MSWM plan by the urban local bodies (ULBs). Every ULB should undertake the preparation of a MSWM plan, addressing short term and long term actions.

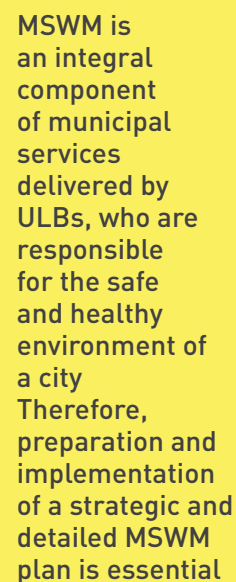

MSWM is an integral component of municipal services delivered by ULBs, who are responsible for the safe and healthy environment of a city. Therefore, preparation and implementation of a strategic and detailed MSWM plan is essential.

## 1.1 REQUIREMENTS AND STIPULATIONS BY THE RULES



Clause 15(a) of Solid Waste Management (SWM) Rules, 2016 stipulate that the local authorities shall “prepare a solid waste management plan as per state policy and strategy on solid waste management within six months from the date of notification of state policy and strategy and submit a copy to respective departments of State Government or Union territory Administration or agency authorised by the State Government or Union territory Administration”

This chapter provides stepwise guidance to local authorities in the preparation of MSWM plans. MSWM is essentially a municipal function; it is mandatory for all municipal authorities to provide this service efficiently to keep the cities and towns clean and to dispose the MSW in an environmentally acceptable manner, complying with the SWM Rules, 2016.

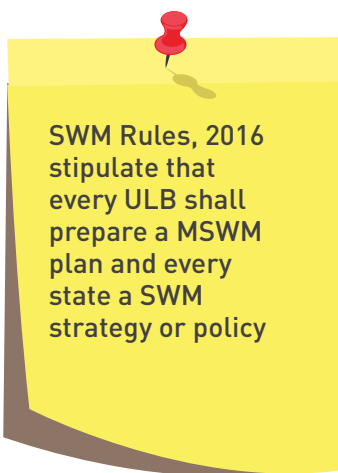

SWM Rules, 2016 stipulate that every ULB shall prepare a MSWM plan and every state a SWM strategy or policy.

It is also pertinent that MSWM systems adopt measures (as per the Supreme Court Directives, 1998) which not only reduce environmental degradation but also look at how high levels of toxins are affecting the health of men, women, and children. The state level municipal acts clearly mention the mandatory functions and additional discretionary functions that the ULBs must perform. ULBs, therefore, have to prioritise their mandatory functions by duly considering their current status and deficiencies.

It is imperative to take stock of the existing situation and develop an MSWM plan, which addresses all aspects of MSWM in compliance with the SWM Rules, 2016 and in alignment with the respective

A long term MSWM Plan: once every 20-25 years

A short term MSWM Plan – once every 5 years

Review of short term plan: once every 2-3 years

State Sanitation Strategy under the National Urban Sanitation Policy (NUSP), and which follows the principles of the Integrated Solid Waste Management (ISWM) hierarchy.

The MSWM plan encompasses:

- (i) institutional strengthening;
- (ii) human resources development;
- (iii) technical capacity building;
- (iv) financial capacity and arrangements (public private partnership [PPP] framework);
- (v) community participation;
- (vi) legal framework and mechanism for enforcement; and
- (vii) public grievance or complaint redressal.

The MSWM plan should consider a long term planning horizon of 20–25 years. Short term implementation plans covering 5 years each should be slotted within the long term plan for ease of implementation. The short term plan should be reviewed and updated once every 2–3 years for any midcourse correction as required. Local authorities should ensure that the short term plan is aligned with long term planning and implementation.

## 1.2 GUIDING PRINCIPLES FOR MUNICIPAL SOLID WASTE MANAGEMENT

### 1.2.1 THE INTEGRATED SOLID WASTE MANAGEMENT SYSTEM

MSWM and adoption of processing technologies are dependent on the quantity and characteristics of the total waste generated in a local authority, the financial resources available, and in-house capability of local authorities to oversee project implementation.



The Integrated Solid Waste Management (ISWM) proposes a waste management hierarchy with the aim to reduce the amount of waste being disposed, while maximizing resource conservation and resource efficiency. The ISWM hierarchy ranks waste management operations according to their environmental, economic, and energy impacts. Source reduction or waste prevention, which includes reuse, is considered the best approach (tier 1); followed by recycling (tier 2); and composting of organic matter of waste, resulting in recovery of material (tier 3). The components of waste that cannot be prevented or recycled can be processed for energy recovery (tier 4). Tier 5 is disposal of waste in sanitary landfill, which is the least preferred option. Based on this waste management hierarchy and local conditions, an appropriate system and technology should be selected in the MSWM plan. For example, if the land for composting organic material is close to habitation, biomethanation may be a preferred choice despite the lower ranking and higher cost as compared to the composting in the ISWM hierarchy.

ISWM is a strategic approach to MSWM in a sustainable manner by considering the generation, segregation, transfer, sorting, treatment, recovery, and disposal of waste in an integrated manner, with an emphasis on maximising efficiency of resource use

**Figure 1.1: Integrated Solid Waste Management System Hierarchy**

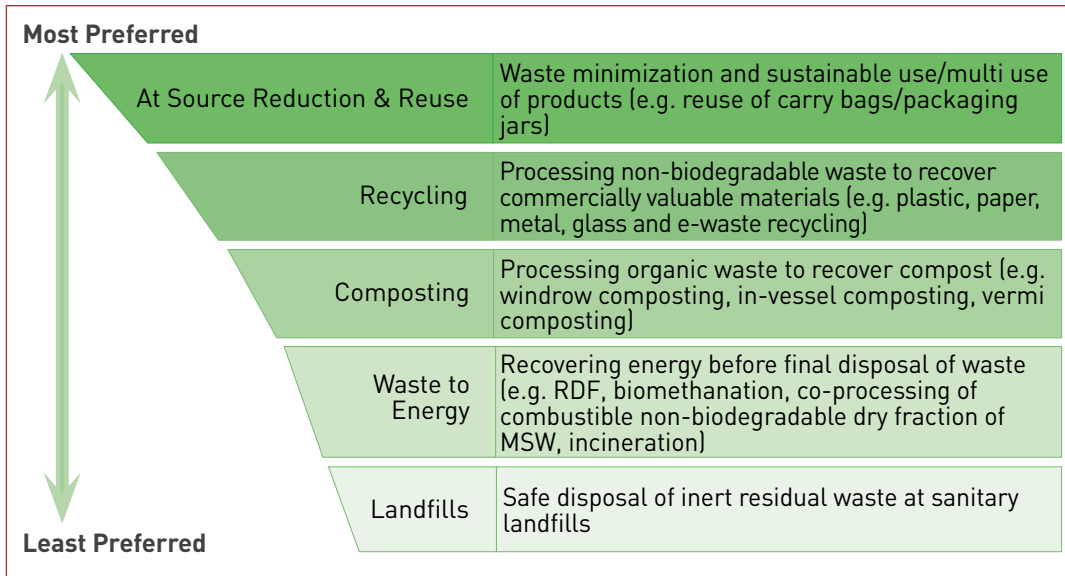

The ISWM hierarchy ranks waste management strategies according to their environmental benefits.

- At source reduction and reuse:** The most preferred option for waste management in the ISWM hierarchy is to prevent the generation of waste at various stages including in the design, production, packaging, use, and reuse of products. Waste prevention helps to reduce handling, treatment, and disposal costs and various environmental impacts such as leachate, air emissions, and generation of greenhouse gases (GHG). Minimisation of waste generation at source and reuse of products are the most preferred waste prevention strategies.
- Waste recycling:** The next preferred option for waste management in the ISWM hierarchy is recycling of waste to recover material resources through segregation, collection, and re-processing to create new products. In the waste management hierarchy, composting is considered as an organic material recovery process and is often considered at the same hierarchical level as inorganic waste recycling.
- Waste to energy:** Where material recovery from waste is not possible, energy recovery from waste through production of heat, electricity, or fuel is preferred. Biomethanation, waste incineration, production of refuse derived fuel (RDF), co-processing of combustible non-biodegradable dry fraction from MSW in cement kilns and pyrolysis or gasification are some waste-to-energy technologies.
- Waste disposal:** Residual inert wastes at the end of the hierarchy are to be disposed in sanitary lined landfills, which are constructed in accordance with stipulations prescribed in SWM Rules, 2016. All over the world, landfills which integrate the capture and use of methane are preferred over landfills which do not capture the landfill gas. As per the hierarchy, the least preferred option is the disposal of waste in open dumpsites. However, Indian laws and rules do not permit disposal of organic matter into sanitary landfills and mandate

Preferential order of waste management options as per the ISWM hierarchy:  
 At Source Reduction and Reuse  
 Waste Recycling  
 Composting  
 Waste to Energy  
 Waste Disposal

that only inert rejects (residual waste) from the processing facilities, inert street sweepings, etc. can be landfilled. In cases where old dumps are to be closed, there is a possibility of capturing methane gas for further use. However, repeated burning of waste significantly decreases the potential of capturing methane.

The hierarchy indicates that all options of source waste minimisation should be utilised before appropriate treatment technologies are selected and implemented.

ISWM is closely linked to the 3R approach (reduce, reuse, and recycle), which also preliminarily emphasises the importance of waste reduction, reuse, and recycling over other forms of waste processing or management. The adoption of these principles helps in minimising the amount of waste to be disposed, thus also minimising the public health and environmental risks associated with it. Maximisation of resource recovery at all stages of solid waste management is advocated by both approaches.

### **1.2.2 EXTENDED PRODUCER RESPONSIBILITY**

Extended producer responsibility (EPR) is a policy approach wherein a producer is held responsible for the post-consumer stage of a product, typically for defined tasks of separate collection (e.g., for e-waste or hazardous waste components), reuse (e.g., disposal-refund systems for bottles), recycling (e.g., for used cars), and storage and treatment (e.g., for batteries). EPR programs are commonly made mandatory through legislation, but can also be adopted voluntarily (i.e., retail take-back programs). National and state level involvement is necessary to ensure that EPR initiatives are successfully implemented. However, ULBs should also encourage local level initiatives based on the principles of EPR (refer to Section 2.1.2 of Part II for further guidance.)

### **1.2.3 DECENTRALISED WASTE MANAGEMENT SYSTEMS**

Decentralised community level waste management systems are preferred to centralised waste management solutions under certain circumstances. Decentralised waste management systems or community level waste management systems reduce the burden of handling large volumes of MSW at a centralised location, with corresponding reduction in costs of transportation and intermediate storage.

Some of the advantages of decentralised waste management include the following:

- Decentralised systems allow for lower level of mechanisation than the centralised solutions, and provide job opportunities for informal workers and small entrepreneurs.
- Decentralised options can be tailor made for the local waste stream, climate, social, and economic conditions.
- Decentralised systems reduce the cost incurred for the collection, transportation, and disposal of waste by the ULBs.

However, ULBs should be aware of some of the limitations of decentralised waste management such as the following:

- difficulty in obtaining land in many urban areas;
- difficulty in maintaining scientific and hygienic conditions due to lack of sufficient space and training and capacity of workers;
- uncertain quality of end products; and
- difficulty in ensuring economic viability of the system, especially when qualified staff is required.

Collection of recyclables at the community level, preferably through involvement of the informal sector, and management of organic waste through home composting systems and community level composting systems are preferred (refer to Section 1.4.5.8 of Part II for further details).

#### **1.2.4 INTEGRATION OF THE INFORMAL SECTOR**

In India the informal sector, comprising of the kabadi system and waste pickers, plays a significant role in collection and processing of recyclable material. There is a significant thrust in various national and state level policies to recognise, identify, and integrate informal sector workers into formal waste management processes and initiatives. Creation of livelihoods, social acceptance, and security for informal sector workers and regularising the recycling sector are all benefits of integrating the informal sector. This may be done effectively by organising them into self-help groups (SHGs) or cooperatives, to capacitate them to work as entrepreneurs in a business entity. In the future, they may own small recycling facilities which are managed scientifically and hygienically (Section 1.4.5.9 of Part II further elaborates these aspects).

## 1.3 OVERVIEW OF DEVELOPING A MUNICIPAL SOLID WASTE MANAGEMENT PLAN IN AN URBAN LOCAL BODY

The preparation of an MSWM plan follows a seven step process, complying with SWM Rules, 2016 and other guidelines provided by the Government of India

Figure 1.2: Seven-Step Approach for Developing a Plan

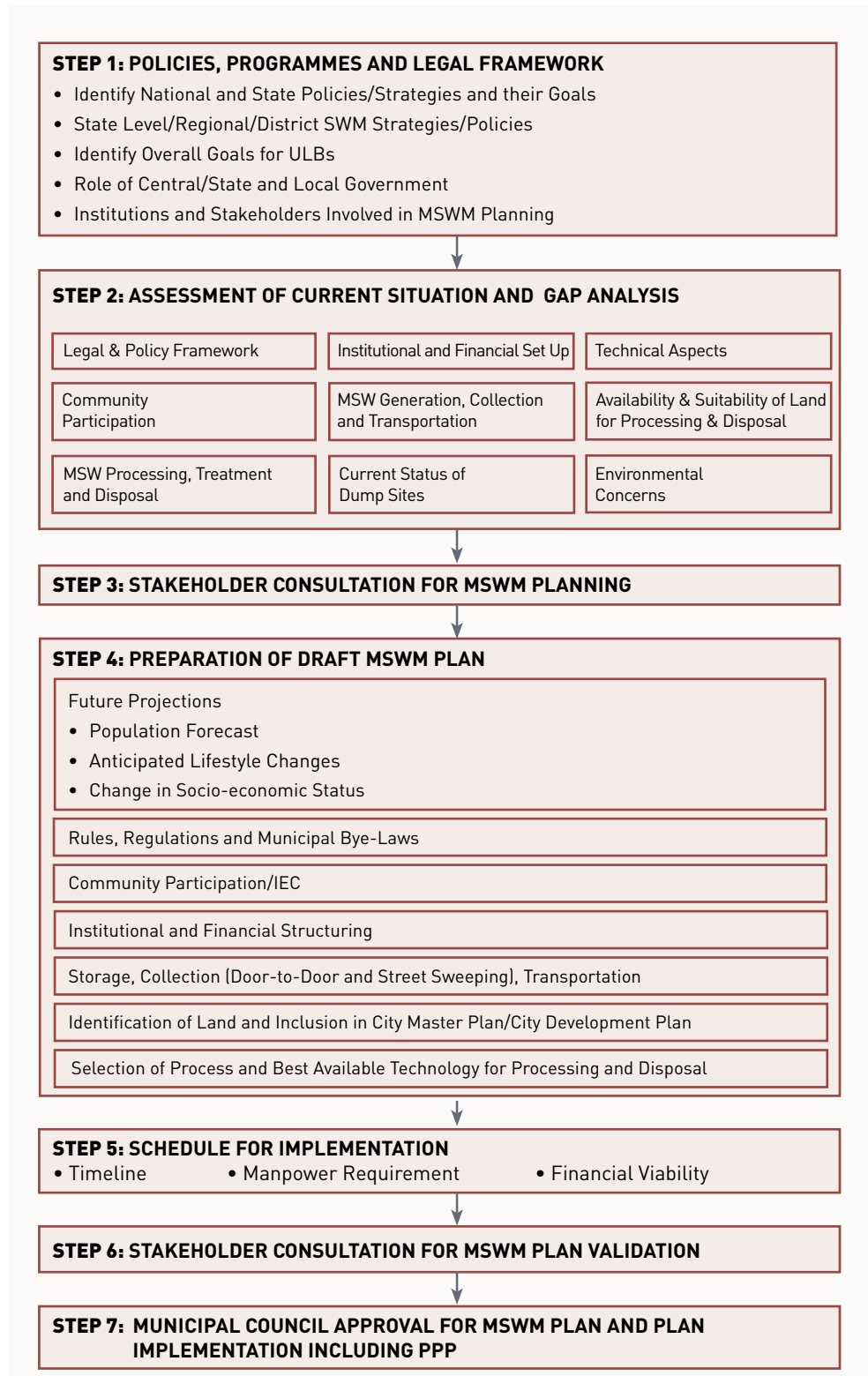



Planning for the MSW management services follows a seven-step process (as illustrated in Figure 1.2), which should be undertaken by all ULBs to ensure compliance with SWM Rules, 2016 and other guidelines provided by the Government of India and respective state governments. The MSWM plan is prepared for 20–25 years and embedded with several short term plans (5 years), which shall be reviewed once every 2–3 years. The following steps provide an overview of the planning process. Each step is further elaborated in Section 1.4.

### **Step 1: Policies, Programmes and Legal Framework**

Step 1 entails a detailed review and analysis of national, state, and municipal level laws, rules, policies, programmes, and guidance related to MSWM. The ULB shall prepare a list of all mandatory and recommended actions required as per SWM Rules, 2016 and other policy guidance and shall ensure that the MSWM plan is developed within these framework conditions.



Step 1: Review and analysis of policies, programmes and legal framework

### **Step 2: Assessment of Current Situation and Gap Analysis**

The municipal authority should then carry out a critical assessment of the current status of SWM in the city as per the SWM Rules, 2016; NUSP; service level benchmarks (SLBs) for SWM service delivery (prescribed by the Ministry of Urban Development [MoUD]), the directives of the State Government and the local Municipal Acts governing the ULBs. The assessment should clearly identify deficiencies or gaps that need to be bridged to meet legal obligations. Gaps with respect to human resources, institutional capacity, infrastructure, financial resources, inclusiveness in service provision, conducive regulatory framework, availability of essential data, land availability, stakeholder willingness, awareness levels, as well as information, education, and communication (IEC) needs of the community should also be identified.

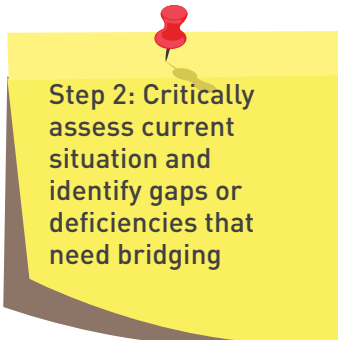

Step 2: Critically assess current situation and identify gaps or deficiencies that need bridging



All aspects of the existing MSWM system need to be considered in detail before MSWM plan can be prepared



## Assessment of Current Municipal Solid Waste Management Situation in the City – What to do?

### Ward-wise and Consolidated Details

- Demographic data of population (which includes sex-disaggregated data), number of households, shops and establishments, population growth pattern, waste generation data
- Physical and chemical composition of waste
- Inventory of human resources at various levels
- Inventory of equipment, bins, vehicles, and available land for municipal solid waste management (MSWM) facilities
- Public private partnership (PPP) status in providing services, extent of private sector participation (PSP) in delivery of service, and cost benefits or quality of service derived
- Involvement of community participation in MSWM with an overview of the kind of community engagement, the outreach services, the number of men and women, and also the activities in engaging communities
- Note on the kind of information, education, and communication (IEC) material developed, whether they target a particular aspect of MSWM and whether the message is gender-sensitive and not merely reinforcing stereotyped roles of men and women

### Storage at Source and Segregation

- Details of waste storage at source and source segregation (including the number of fractions in which waste is segregated)

### Primary Collection System in Practice

- Door-to-door collection, collection from community bins or any other method, requirements of collectors, frequency of collection, percentage of coverage under each collection method including a proper gap analysis

### Street Sweeping

- Frequency of street sweeping, coverage, inclusiveness of slums and informal settlements, and safety provisions

### Secondary Storage

- Secondary storage in covered street bins, containers, masonry, concrete bins, enclosures, dhalaos, open waste storage sites, or any other method, bin-population ratio, or no secondary storage (direct transportation of waste)

### **Transportation**

- Type and number of vehicles used, quantity and percentage of waste transported each day in covered vehicles and open vehicles, frequency of transportation from secondary storage sites, percentage of manual loading in relation to mechanical loading

### **Processing of Waste**

- Quantity and percentage of waste processed, technology adopted, percentage of residual waste sent to disposal site, realisation of revenues from the processing facility, beneficiaries of the revenues

### **Disposal of Waste**

- If the city has a sanitary landfill? If yes, area, designated site, and capacity of the landfill, volume of the current cell and expected life, quantity of waste deposited annually at the landfill (over the life of the landfill)
- Identifying location of existing dump sites and issues with these sites
- Land availability for MSWM as per city development plan or city master plan

### **Financial Assessment**

- The budgetary allocations and actual annual expenditure on MSWM services in relation to total revenue budget of the municipal authority
- Cost per tonne of various components of MSWM service
- Assessment of tax or user fees levied for providing MSWM service and extent of cost recovery

### **Assessment of Social Impacts**

- Estimate the impacts of the existing waste management system on the informal sector of kabadi system and waste pickers, either negatively (hygienic impacts) or positively (revenues for the informal sector)

### **Assessment of Environmental and Health Impacts**

- Impacts on the environment and public health due to existing waste management practices, impact on groundwater, soil, etc.
- Assess existing MSWM facilities and related land use issues and old dumpsite closure issues
- Analyse gaps (including socioeconomic and gender-related disparities that may exist) focusing on deficiencies of the existing system by reflecting all issues mentioned above
- Compare the current situation with service level benchmarks (SLBs) prescribed by the Government of India

### **Step 3: Stakeholder Consultation for Planning**

MSWM has a direct relation with the community and other waste generators. Due to the number of institutions and stakeholders involved in MSWM, it is important that the MSWM plan, which aims to bridge the gaps or improve the level of service, is developed through a consultative process. Stakeholders' views, including their willingness to participate and pay for the service, should be considered. ULBs shall ensure that women, as important providers of MSWM services as well as beneficiaries of these services, shall be adequately involved in the stakeholder consultations and decision making processes.

### **Step 4: Preparation of Draft Municipal Solid Waste Management Plan**

Identified gaps, future population projections and waste generation rates, current and future quality and quantity of waste (based on changing lifestyles and economic status), inputs from stakeholders, financial situation, and technical capabilities of the local body should be assessed. The municipal authority should prepare its draft short term and long term MSWM plan, considering the provisions of the local Municipal Act, SWM Rules, NUSP, and SLBs. Requirements for equipment, vehicles, staffing, land revenues etc., for providing door-to-door collection, street sweeping, secondary storage, transportation, processing, and final disposal of waste should be considered.

Waste minimisation or reduction, waste reuse, and waste recycling practices (3Rs) have a significant impact on the waste composition and quantities of waste to be handled and disposed. ULBs should therefore plan for an effective IEC campaign to promote the concept of 3Rs to minimise waste generation. Decentralised approaches for treatment and disposal of waste will also reduce waste quantities to be transported and handled as compared to centralised plants, and should therefore be included in the MSWM plan, wherever appropriate.

The size of the city; projected waste generation rate; waste characterisation; geographical location; climatic conditions; hydro-geological conditions and environmental, social, and economic considerations have an impact on the selection of appropriate systems and technologies for processing and disposal of waste.

The choice of technologies should be guided by proven performance track records within or outside India, technical feasibility under local conditions, financial viability or potential for cost recovery and environmental regulations.

The institutional framework for providing MSWM services and its monitoring and supervision through municipal departments or PPP need to be planned. Depending on the size of the city, a dedicated



Adoption of novel technologies, whose performance has not been proved in the Indian context and whose performance is dependent on very specific input waste characteristics should be avoided.

MSWM department, an MSWM cell, or responsible staff should be made accountable for MSWM and implementation of the MSWM plan in the city. Duties of the responsible staff should be detailed out and disclosed to the general public. Capacity building needs of staff must be addressed.

Identifying appropriate benchmarks for performance and delivery of MSWM services is an integral part of the planning process. As a minimum, the SLB indicators need to be regularly monitored. Performance of all contracted services shall also be appropriately monitored, reported, and analysed. A management information system (MIS) should be set up to record and monitor all information or data on MSWM.

#### **Step 5: Schedule for Implementation**

An implementation plan, indicating allocation of resources and specifying timelines should be prepared. The implementation plan should address institutional strengthening; raising financial resources through rationalising taxes and supported by user fees as per the relevant regulations; accessing loans from financial institutions; and obtaining government grants, specific project development, and rollout. The institutional and financial operating plan should be an integral part of the MSWM plan. PPP for infrastructure development and service delivery may be fully explored during this exercise. A macro-level time plan for implementation of key activities proposed under the short term and long term plans should be included in the MSWM plan.

#### **Step 6: Stakeholder Consultation for Municipal Solid Waste Management Plan Validation**

Provision of effective MSWM services is substantially dependent on community behaviour and practices. Segregation of waste at source, delivering waste to doorstep collectors, avoiding littering, participating in waste recycling, buyback programmes and, most importantly, exploring options for waste minimisation are all dependent on active and appropriate public involvement and support. Citizens should be made aware of the full scale of MSWM services provided by the ULBs and their potential involvement in implementing the plan. Including women in the plan validation and decision-making process is critical for ensuring successful plan implementation. The financial, health, and environmental benefits accruing under the MSWM plan should be determined and highlighted.

## Step 7: Municipal Council Approval for Municipal Solid Waste Management Plan and Implementation Including Public Private Partnership

The final MSWM plan is to be presented to the elected body of the local authority to seek approval and to officially formalise the plan. Municipal council should be made aware of the short term and long term actions and should also approve the financial plan for implementation of these actions. PPP or private operators should also be made aware of the MSWM plan. Contracting models should be transparent and performance based. Both the ULB and PPP operator should be accountable for their roles to ensure successful and sustainable project implementation.

## 1.4 SEVEN STEP APPROACH FOR MUNICIPAL SOLID WASTE MANAGEMENT PLANNING

### 1.4.1 STEP 1: POLICIES, PROGRAMMES AND LEGAL FRAMEWORK

Figure 1.3: Step 1 in Municipal Solid Waste Management Plan

| STEP 1 |  |
|--------|--|
| Step 2 | <b>STEP 1: POLICIES, PROGRAMMES &amp; LEGAL FRAMEWORK</b> <ul style="list-style-type: none"><li>• Identify National and State Policies/Strategies and their Goals</li><li>• State Level/Regional/District SWM Strategies/Policies</li><li>• Identify Overall Goals for ULBs</li><li>• Role of Central/State and Local Government</li><li>• Institutions and Stakeholders Involved in MSWM Planning</li></ul> |
| Step 3 |  |
| Step 4 |  |
| Step 5 |  |
| Step 6 |  |
| Step 7 |  |

#### 1.4.1.1 IDENTIFY NATIONAL AND STATE POLICIES OR STRATEGIES AND THEIR GOALS

The Government of India has undertaken a number of initiatives to address MSWM issues since 2000.<sup>1</sup> The policy interventions by the Government of India in MSWM can be traced back to 1960s, when the Ministry of Food and Agriculture (MoA) announced loans for composting of solid waste. However, a focused policy approach towards managing solid waste gained momentum only after the plague outbreak in Surat in 1994. The J.S. Bajaj Committee constituted in 1995 by the Planning Commission immediately after the plague outbreak, made wide-ranging recommendations including waste segregation at source, primary collection, levy of user charges, use of appropriate equipment and vehicles, and focus on composting and landfilling. Parallel to this, the Ministry of Health and Family Welfare initiated a National Mission

Identify relevant policies, programmes and applicable legal framework

<sup>1</sup> Toolkit for Solid Waste Management (2012), Jawaharlal Nehru National Urban Renewal Mission, Ministry of Urban Development, Government of India. <http://jnurm.nic.in/wp-content/uploads/2012/11/SWM-toolkit.pdf>

on Environmental Health and Sanitation while the Central Public Health and Environmental Engineering Organisation (CPHEEO) under MoUD prepared a draft policy paper that detailed funding issues and requirements for MSWM.

The Ministry of Environment, Forests and Climate Change (MoEFCC) notified the Municipal Solid Waste (M&H) Rules in September 2000. The rules provide detailed guidelines on various aspects of MSWM and identify the Central Pollution Control Board (CPCB) and the State Pollution Control Boards (SPCBs) as nodal agencies to monitor its implementation directly in the union territories and the states respectively. The Ministry of Environment Forests and Climate Change has recently revised the rules and renamed it as Solid Waste Management Rules, 2016.

Other policy initiatives which inform and guide provision of MSWM services include the recommendations of the Technical Advisory Group on MSWM (2005) and the Inter-Ministerial Task Force on Integrated Plant Nutrient Management (2005); the Hazardous Waste (Management, Handling & Transboundary Movement) Rules (1989, 2008); Bio-Medical Waste Management Rules (2016); the Plastic Waste Rules (2016); and the E-Waste Rules (2016). All of these cover specific types of waste that are not regulated by the MSW (M&H) Rules, 2000. However, they provide guidance to the management of certain streams of waste which may otherwise inadvertently find their way into the municipal waste streams.

Launched in 2014 under the flagship programme namely Swachh Bharat Mission aims to provide the sanitation facilities with respect to scientific municipal solid waste management and liquid waste management to every citizens. SBM stipulates to build the capacities of urban local bodies strong in order to design, execute and operate all systems related to service provision. This requires close linkage between planning, operationalising and sensitizing of the sanitation and waste management services within the departments as well as the citizens for achieving the overall goal of SBM. The initiative has also encouraged the participation of private sector by providing the suitable environment for their active and reliable participation in the sector.

Introduced in 2008, the National Urban Sanitation Policy (NUSP) broadly covers aspects of urban sanitation. MSWM is an important focus area in the NUSP. The NUSP stipulates that MSWM should also be covered in the state sanitation strategy (SSS) and the city sanitation plan (CSP). This requires close linkages between the waste management and the sanitation planning in a particular ULB. The National Mission on Sustainable Habitat, which was approved in 2008 under the National Action Plan on Climate Change (NAPCC), highlights the importance of adopting recycling strategies to avoid greenhouse gas (GHG) emissions.



In order to better manage MSW within their jurisdiction, ULBs should be aware of the other different categories of waste that should not be allowed to mix with MSW

There are the rules, regulations, policies, and reforms that guide the MSWM service delivery (Table 1.1). Provisions for floating tax-free bonds by ULBs, income tax relief to waste management agencies, introduction of double accounting system in ULBs, development of model municipal bye-laws are other major policy or regulatory directives which guide ULBs in certain aspects of planning for and operationalising MSW services. Overarching guidelines for private sector participation (PSP) and PPP arrangements have also been drawn by the Department of Economic Affairs. The “Toolkit for Public Private Partnership Frameworks in Municipal Solid Waste Management” was developed by the Ministry of Urban Development.

**Table 1.1: Important Policy Landmarks and Initiatives by Government of India<sup>2</sup> on Solid Waste Management**

| YEAR      | RULES, POLICIES, SCHEMES, FINANCIAL PLANS   |
|-----------|---|
| 1989      | The Hazardous Waste (M&H) Rules   |
| 1994–1995 | MSWM strategy paper by NEERI<br>J.S. Bajaj Committee (The High Powered Committee on Urban Solid Waste Management)   |
| 1998      | Bio-medical Waste (M&H) Rules<br>Supreme Court appointed Barman Committee   |
| 2000      | MSW (M&H) Rules<br>CPHEEO Manual on MSW   |
| 2005      | Report of the Technology Advisory Group on SWM<br>JNNURM (2005–2012)—40 MSW projects costing Rs. 2,186 Cr sanctioned from a total of 65 cities covered<br>UIDSSMT (2005–2012)—51 MSW projects costing Rs. 327 Cr sanctioned from a total of 632 cities covered<br>12 <sup>th</sup> Finance Commission (2005–2010)—Rs. 2,500 Cr for 423 Class I cities |
| 2006      | Strategy and Action Plan-Use of compost in cities   |
| 2007      | 11 <sup>th</sup> Five-Year Plan (2007–2012)—Rs. 2,210 Cr for MSWM   |
| 2008      | National Urban Sanitation Policy (NUSP)<br>Service Level Benchmarks (SLBs) in MSWM<br>Hazardous Waste (Management, Handling & Transboundary Movement) Rules<br>National Mission on Sustainable Habitat (NAPCC)  |
| 2010      | 13 <sup>th</sup> Finance Commission (2010–2015)—Establishing standards for delivery of essential services   |
| 2011      | Plastic Waste (M&H) Rules<br>E-Waste (M&H) Rules<br>Draft Bio-medical Waste (M&H) Rules   |
| 2014      | Swachh Bharat Mission, October 2014   |
| 2016      | Waste Management Rules, 2016 comprising of Solid Waste Management Rules, Plastic Waste Management Rules, Bio-Medical Waste Management Rules, E-Waste Management Rules, Hazardous and Other Wastes (Management and Transboundary Movement) Rules, 2016 and Construction and Demolition Waste Management Rules, 2016.                                   |

<sup>2</sup> Toolkit for Solid Waste Management (2012), Jawaharlal Nehru National Urban Renewal Mission, Ministry of Urban Development, Government of India. <http://jnnurm.nic.in/wp-content/uploads/2012/11/SWM-toolkit.pdf>



### 1.4.1.2 STATE LEVEL MUNICIPAL SOLID WASTE MANAGEMENT STRATEGIES OR POLICIES

MSWM plans should take cognisance of state level SWM strategies and policies. These policies provide further guidance to ULBs to implement the SWM Rules, 2016.

While various states are in the process of defining the state level MSWM strategy, some states like Karnataka and, most recently, Andhra Pradesh have notified state level MSWM strategies.



#### **Karnataka State Policy on Integrated Waste Management**

The State Government of Karnataka adopted a policy on integrated solid waste management (ISWM) in 2004 with the objective of developing and implementing scientific and sustainable methods for municipal solid waste management (MSWM). Funds were made available under 11<sup>th</sup> Finance and 12<sup>th</sup> Finance Commissions for purchase of land, development of landfill sites, procurement of tools, equipment & vehicles and IEC activities.

The primary objectives of the Karnataka State policy on ISWM are to:

- provide directions for MSWM activities in an environmentally, socially, and financially sustainable manner;
- establish an integrated and self-contained operating framework for MSWM; and enhance the ability of ULBs to provide effective waste management services to their citizens.

Some of the principles of the state policy on ISWM include:

- promoting public awareness regarding minimizing and avoiding multiple handling of waste;
- defining the roles and responsibilities of various stakeholders in an operating framework;
- developing systems for effective resource utilisation and deployment;
- promoting recovery of value from municipal solid waste (MSW); and
- developing treatment and final disposal facilities as per statutory requirements.

In order to enhance the stakeholders' involvement in MSWM, the state policy also proposes the following innovations:

- The responsibility of source segregation and primary collection shall be entrusted to the waste generator level (community-based organisations);
- Information, education, and communication (IEC) activities and awareness programs shall be developed and maintained;
- The role of non-government organisations (NGOs) as a communication bridge among the ULB, community, self-help groups (SHGs), and resident welfare associations (RWAs) shall be defined and utilized to help in promoting awareness programme and to engage with communities in understanding difficulties, gaps, and challenges in implementation. There shall be recommendations and consultations with NGOs or RWAs on how to ensure an effective MSWM system;
- ULBs shall allow RWAs or SHGs to contract with private operators for various waste management activities, under specified guidelines and structures.

The state policy on various activities of MSWM includes the following:

- **Primary collection:** The ULBs shall charge a user fee for door-to-door collection. The MSW from bulk generators shall be collected and transferred directly to the secondary transport system.
- **Street sweeping and drain cleaning:** ULBs shall enter into appropriate contractual agreement with private operators for street sweeping and should engage in fair wage practices.
- **Secondary collection and transportation:** The ULBs shall abide by the statutory guidelines of SWM Rules, 2016 and adopt the rule of thumb of usage of metal containers and reduced multiple handling by using dumper placers or tractors with tipping trailer mechanism.
- **Treatment and disposal:** The ULBs shall make a well-informed decision while selecting treatment technologies and shall contract private partners on a tipping fee basis. The policy follows the SWM Rules, 2016 and maintains that all Class I cities in the state shall have both compost plants and landfill sites, while other cities or towns with a population of less than 1 lakh shall have only suitable engineered landfill sites.

Facilitating establishment of regional facilities and promoting decentralised waste management facilities, as appropriate, should be included in the key provisions of the state level strategy

### 1.4.1.3 IDENTIFY AND ANALYSE REGIONAL OR DISTRICT SOLID WASTE MANAGEMENT PLANS

Technical, financial, and managerial challenges of MSWM in cities can be addressed by considering regional arrangements for MSWM.<sup>3</sup>

Some of the benefits of regional MSWM facilities are the following:

- enable authorities to take advantage of economies of scale by collecting inert waste generated across their respective jurisdictions. These facilities reduce the financial and technical burden on each individual authority and help authorities address MSW management in a cost effective manner. They also enable access to technologies requiring a higher order of resources other than available with a single ULB.
- results in more efficient use of land and other scarce natural resources within the region.



Guidance for establishing regional facilities shall be provided by the state governments. A solid waste management cell may be constituted within the Urban Development Department at state level or within the Directorate or Commissionerate of Municipal Administration or its equivalent department. Policy decisions regarding criteria for clustering of ULBs, structure of partnerships and guidance on cost and revenue sharing, and ensuring protection of human rights of all workers or labourers shall be taken by this state level nodal agency.

<sup>3</sup> Municipal Solid Waste Management on a Regional Basis; Ministry of Urban Development; available at: [http://www.urbanindia.nic.in/programme/uwss/mswm/msw\\_guide\\_note.pdf](http://www.urbanindia.nic.in/programme/uwss/mswm/msw_guide_note.pdf)

### 1.4.1.3.1 Objectives of Regional Solid Waste Management Plans

A regional MSWM facility serves multiple ULBs and facilitates regional level disposal of MSW. In cases where land is not available for processing and disposal, regional processing and disposal facilities may be proposed. To the extent possible, efforts should be made to treat waste locally. Only in cases where there is scarcity of land or expertise, regional processing facilities shall be proposed.

With a view to reduce expenditure of hauling small quantities of waste to regional facilities, transfer stations may be established. Regional systems benefit both large municipal bodies, which experience scarcity of land resources, and smaller municipalities, which are challenged by limited technical and financial resources for establishing their own facilities.

Regional approach facilitates establishment of MSW processing and disposal facilities for ULB clusters, and benefits both large and small ULBs



Availability of land in urban areas is one of the major constraints in management of waste. With an increase in urban population, the land requirements for management of waste also increase. It is however not economically viable for each small ULB to maintain and operate a treatment and sanitary landfill facility.

ULBs are therefore encouraged to develop organic waste processing facilities locally; inerts and process rejects may be hauled from a transfer facility to a centralised or regional processing facility. In cities with a population of over 1 lakh, where the dry and inert waste is being transferred to a regional facility, a transfer station should be constructed for the storage of waste; the capacity may be decided based on a viable size for transport up to the regional facility. Long haul container systems should be used to transport this waste to the regional waste processing or landfill facility.



The Suchitwa Mission of the State Government of Kerala initiated a study to compare the costs of providing sanitary landfills in all of its 5 city corporations and 49 municipalities. The State of Kerala is constrained by the lack of suitable land for landfill construction. Therefore, regional sanitary landfill facilities (SLFs) are suggested. A comparative study on the land and cost requirements for an SLF for a single ULB and the requirements for a regional SLF are given below.

| NO | ITEM  | INDIVIDUAL SLF FOR EACH ULB | REGIONAL SLF |
|----|---|-----------------------------|--------------|
| 1  | Land requirement (hectare)                          | 2316                        | 957          |
| 2  | Cost of land (Rs per ha)                            | 0.40 crores                 | 0.18 crores  |
| 3  | Savings on land cost (Rs)                           | 754 crores                  |              |
| 4  | Operation and Maintenance (O&M) cost per tonne (Rs) |                             | 388          |
| 5  | Savings per annum on O&M (Rs)                       | 13 crores                   |              |

Source: Suchitwa Mission. <http://www.sanitation.kerala.gov.in/>

### 1.4.1.3.2 Institutional Aspects of Regional Approaches

A regional facility entails an institutional arrangement that enables the association of partnering municipalities to provide specific MSWM services. Some of the attributes of a regional approach are the following:<sup>4</sup>

- It is constituted specifically to provide a particular service (MSW processing or disposal).
- It is governed by a board of directors, a council, or an executive body which is unique to the organisation.
- It is usually not dependent on taxes for funding, but raises fund through service tipping fees paid by partnering local bodies.
- It may or may not involve the participation of a private sector service provider.
- It often requires special legislation and ordinances for its establishment.

### 1.4.1.3.3 Implementation of Regional Municipal Solid Waste Management Plans

Regional projects can be implemented through any of the following:<sup>5</sup>

**Inter-municipal agreements:** These are contracts between two or more municipalities who combine their resources to perform a specific task together. The primary advantages of inter-municipal agreements are flexibility and customisation. Inter-municipal agreements are often better suited for limited regional projects. One of the challenges to these agreements is the difficulty in obtaining capital financing because each participating municipality might have to raise money for the project individually.

**Authorities, trusts, and special districts:** These can be created by governments dedicated to organise their regional programs. These entities have the power to impose regulations, contract with private companies, issue bonds, levy taxes or assessments, or use other means to raise funds for specific projects.

**Regional councils:** These are another approach used for inter-municipal cooperation to organise and manage all types of cooperative projects. The council provides flexibility and helps in bringing public and private partners together to make decisions.

**Private sector participation:** This can be used for different services like transporting MSW to the regional landfill system, financing,

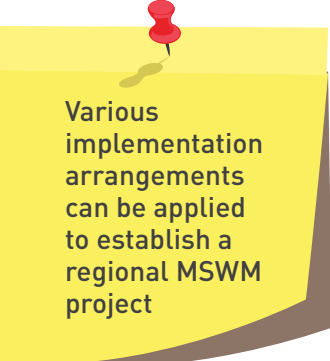

Various implementation arrangements can be applied to establish a regional MSWM project

4 'Moving Towards the Regional Approach, Water and Sanitation Program', Water and Sanitation Program (2007). Available at [http://www.wsp.org/sites/wsp.org/files/publications/519200880608\\_SWM\\_dec\\_07.pdf](http://www.wsp.org/sites/wsp.org/files/publications/519200880608_SWM_dec_07.pdf)

5 'Improving Solid Waste Management in India', D. Zhu, et al., (2008). Available at: [http://www.tn.gov.in/cma/swm\\_in\\_india.pdf](http://www.tn.gov.in/cma/swm_in_india.pdf)

construction, and operation. Regional organisations can enter into binding agreements with businesses to provide specified and improved services at less cost. Contracts between local governments and businesses generally are governed by the public contracting laws of the state.

Some of the guiding principles that should be taken into consideration while planning, developing, implementing, and managing regional MSW projects are discussed briefly below.

#### 1.4.1.3.4 Land Allocation for Regional Municipal Solid Waste Projects

Land for a regional MSW project can be provided through any of the following mechanisms:

- provided and owned by the state government or by one of the authorities participating in the regional MSW project;
- acquired by one of the participating authorities and allocated by passing appropriate resolutions, without any state government assistance;
- acquired by the state government and vested with a particular municipality or a group of municipalities; and
- provided by the private sector participant.

Before the selection of any site for the development of a regional MSW facility, it should be ensured that the land use cannot be changed by the competent authority for the duration of the project to ensure bankability and viability of the project. Moreover, the following should be noted:

- The area of land being provided should be sufficient to enable the type of regional MSW facility intended to be developed using specified technology.
- The location should enable optimum number of authorities to have viable access to the facility.
- Land that is already within the possession of either the state government or any authority may be preferred over lands that require acquisition from private or other entities.
- Acquisition of privately owned land may be undertaken in cases where no government land is available.
- Land that has been identified for development or implementation of regional MSW projects shall be notified as having been allocated for the purpose of regional MSW projects only.



Land identified for a regional facility cannot be assigned to other uses to ensure and protect the viability of proposed MSWM facilities

- The state government should control land use in and around the regional MSW facility in accordance with development controls to prevent encroachment or development of habitations, structures, etc.

#### 1.4.1.3.5 Solid Waste Quantity and Tipping Fee

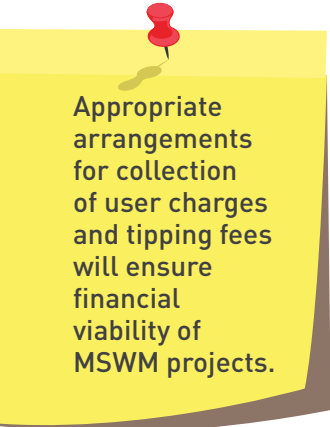

Appropriate arrangements for collection of user charges and tipping fees will ensure financial viability of MSWM projects.

- Depending on the type of waste processing facility to be established, each authority shall have to assure a certain quality and quantity of MSW it supplies to the project.
- The tipping fee should be structured so as to enable viable implementation of the project depending on the circumstances and the location of the project.
- In order to guarantee their ability to pay the tipping fee, each participating authority shall make appropriate arrangements such as imposing and collecting fees from within its jurisdiction for the provision of MSW services. An escrow account and charge structure with respect to the identified revenue streams may be created to provide for security of payment of the tipping fee.
- State governments may also resort to an intercept mechanism whereby, the State Government may provide the required payments directly, for and on behalf of the Authority. Under the proposed structure, the participating authorities will contractually agree to the State intercept mechanism.

#### 1.4.1.3.6 Collection and Transportation of Municipal Solid Waste

The authorities participating in a regional MSW project should undertake to improve the efficiency of their MSW collection and transportation systems in a phased and time-bound manner to ensure that the minimum quantity of waste reaches the processing facility or disposal site on a regular basis.



### Examples of Regional or Inter-Municipal Arrangements currently under Development<sup>6</sup>

**Gujarat:** Regional landfill sites have been identified in Gujarat: 45 sites have been proposed for 161 municipalities; with a maximum transport distance of 25 km. Proposals envisage private sector involvement and the Gujarat State Waste Management Company will be the sole contracting agent. Memorandum of understanding will be signed between the cooperating municipalities and the state nodal agency. Nine sites are at an advanced stage of construction of sanitary landfill facilities.

**Kerala:** A study conducted by Suchitwa Mission recommended that the 14 districts in the state be divided into 6 zones, each with its own landfill site for receiving waste from all towns in that particular zone. The feasibility study for construction of one regional landfill has commenced.

**West Bengal:** In the Kolkata Metropolitan Development Authority area, six municipalities propose to use one common landfill site. Regional landfills are also being planned in other parts of the state such as the Asansol Municipal Corporation and Durgapur Municipal Corporation. The municipalities of Raniganj, Jamuria, and Kulti, under the nodal Asansol Durgapur Development Authority, have developed a regional engineered landfill facility. A public private partnership was formed for project implementation.

**Maharashtra:** The Mumbai Metropolitan Regional Development Authority has decided to develop a regional landfill facility to cater to 2,500 tons of waste with a design period of 25 years. Urban local bodies (ULBs) in the metropolitan region from six municipal corporations or councils are envisaged to use this facility such as Kalyan-Dombivali, Bhiwandi-Nizampur, Ulhasnagar, Ambarnath, and Kulgaon-Badlapur.

**Orissa:** The cities of Bhubaneswar and Cuttack have associated to commission a common municipal solid waste management facility for treating approximately 600 tonnes of waste from both ULBs. The Orissa Industrial Infrastructure Development Corporation is acting as transaction advisory to facilitate this project. The selected concessionaire will be responsible for designing and constructing the requisite transfer station; transporting waste from the transfer station to the waste management facility; and identifying, designing, constructing, and operating waste management facilities based on appropriate technologies selected by the concessionaire.

**Andhra Pradesh:** The state government has developed a strategy and issued comprehensive guidelines for setting up regional facilities. 124 ULBs have been clubbed into 19 clusters. Five facilities were established and operated through private sector concession agreements.

<sup>6</sup> Adopted from "Moving Towards the Regional Approach, Water and Sanitation Program", Water and Sanitation Program (2007); and further updated by the Expert Committee for revision of MSWM manual (2013-15).

#### 1.4.1.4 ROLE OF CENTRAL, STATE AND LOCAL GOVERNMENTS

While the onus of providing MSWM services in urban areas lies with the ULBs, central and state governments have a significant role to play in defining the framework within which service provision can be planned and executed by ULBs. The following are prescribed authorities and their roles and responsibilities in relation to ensuring the implementation of the provisions of the SWM Rules, 2016.

**Table 1.2: Role of Central, State and Local Governments in Municipal Solid Waste Management**

| LEVEL OF GOVERNMENT | ROLE   |
|---------------------|--|
| Central Government  | <ul style="list-style-type: none"> <li>• Legal &amp; Policy Framework: The SWM Rules, 2016 by the Ministry of Environment, Forest &amp; Climate Change (MoEFCC) mandate provision of MSWM services by municipal authorities in urban areas in the country.</li> </ul> <p>Clause 5: Duties of Ministry of Environment, Forest and Climate Change.-</p> <p>(1) The Ministry of Environment, Forest and Climate Change shall be responsible for over all monitoring the implementation of these rules in the country. It shall constitute a Central Monitoring Committee under the Chairmanship of Secretary, Ministry of Environment, Forest and Climate Change comprising officer not below the rank of Joint Secretary or Advisor from the following namely,-</p> <p>Ministry of Urban Development, Ministry of Rural Development, Ministry of Chemicals and Fertilizers, Ministry of Agriculture, Central Pollution Control Board, Three State Pollution Control Boards or Pollution Control Committees by rotation, Urban Development Departments of three State Governments by rotation, Rural Development Departments from two State Governments by rotation, Three Urban Local bodies by rotation, Two census towns by rotation, FICCI, CII, Two subject experts</p> <p>(2) This Central Monitoring Committee shall meet at least once in a year to monitor and review the implementation of these rules. The Ministry of Environment, Forest and Climate Change may co-opt other experts, if needed. The Committee shall be renewed every three years.</p> <p>Clause 6: Duties of Ministry of Urban Development.- (1) The Ministry of Urban Development shall coordinate with State Governments and Union territory Administrations to,-</p> <p>(a) take periodic review of the measures taken by the states and local bodies for improving solid waste management practices and execution of solid waste management projects funded by the Ministry and external agencies at least once in a year and give advice on taking corrective measures;</p> <p>(b) formulate national policy and strategy on solid waste management including policy on waste to energy in consultation with stakeholders within six months from the date of notification of these rules;</p> <p>(c) facilitate States and Union Territories in formulation of state policy and strategy on solid management based on national solid waste management policy and national urban sanitation policy;</p> |



**Table 1.2: Role of Central, State and Local Governments in Municipal Solid Waste Management [contd.]**

| LEVEL OF GOVERNMENT | ROLE   |
|---------------------|--|
|                     | <p>(d) promote research and development in solid waste management sector and disseminate information to States and local bodies;</p> <p>(e) undertake training and capacity building of local bodies and other stakeholders;and</p> <p>(f) provide technical guidelines and project finance to states, Union territories and local bodies on solid waste management to facilitate meeting timelines and standards.</p> <p>Clause 7: Duties of Department of Fertilisers, Ministry of Chemicals and Fertilisers.-<br/>(1) The Department of Fertilisers through appropriate mechanisms shall,-</p> <p>(a) provide market development assistance on city compost; and</p> <p>(b) ensure promotion of co-marketing of compost with chemical fertilisers in the ratio of 3 to 4 bags: 6 to 7 bags by the fertiliser companies to the extent compost is made available for marketing to the companies.</p> <p>Clause 8. Duties of Ministry of Agriculture, Government of India.- The Ministry of Agriculture through appropriate mechanisms shall,-</p> <p>(a) provide flexibility in Fertiliser Control Order for manufacturing and sale of compost;</p> <p>(b) propagate utilisation of compost on farm land;</p> <p>(c) set up laboratories to test quality of compost produced by local authorities or their authorised agencies; and</p> <p>(d) issue suitable guidelines for maintaining the quality of compost and ratio of use of compost visa-a-vis chemical fertilizers while applying compost to farmland.</p> <p>Clause 9. Duties of the Ministry of Power.-The Ministry of Power through appropriate mechanisms shall,-</p> <p>(a) decide tariff or charges for the power generated from the waste to energy plants based on solid waste.</p> <p>(b) compulsory purchase power generated from such waste to energy plants by distribution company.</p> <p>Clause 10. Duties of Ministry of New and Renewable Energy Sources- The Ministry of New and Renewable Energy<br/>Sources through appropriate mechanisms shall,-</p> <p>(a) facilitate infrastructure creation for waste to energy plants; and</p> <p>(b) provide appropriate subsidy or incentives for such waste to energy plants.</p> |

**Table 1.2: Role of Central, State and Local Governments in Municipal Solid Waste Management [contd.]**

| LEVEL OF GOVERNMENT | ROLE   |
|---------------------|--|
|                     | <p>Clause 14: Duties of Central Pollution Control Board.-The Central Pollution Control Board shall, -</p> <ul style="list-style-type: none"> <li>(a) co-ordinate with the State Pollution Control Boards and the Pollution Control Committees for implementation of these rules and adherence to the prescribed standards by local authorities;</li> <li>(b) formulate the standards for ground water, ambient air, noise pollution, leachate in respect of all solid waste processing and disposal facilities;</li> <li>(c) review environmental standards and norms prescribed for solid waste processing facilities or treatment technologies and update them as and when required;</li> <li>(d) review through State Pollution Control Boards or Pollution Control Committees, at least once in a year, the implementation of prescribed environmental standards for solid waste processing facilities or treatment technologies and compile the data monitored by them;</li> <li>(e) review the proposals of State Pollution Control Boards or Pollution Control Committees on use of any new technologies for processing, recycling and treatment of solid waste and prescribe performance standards, emission norms for the same within 6 months;</li> <li>(f) monitor through State Pollution Control Boards or Pollution Control Committees the implementation of these rules by local bodies;</li> <li>(g) prepare an annual report on implementation of these rules on the basis of reports received from State Pollution Control Boards and Committees and submit to the Ministry of Environment, Forest and Climate Change and the report shall also be put in public domain;</li> <li>(h) publish guidelines for maintaining buffer zone restricting any residential, commercial or any other construction activity from the outer boundary of the waste processing and disposal facilities for different sizes of facilities handling more than five tons per day of solid waste;</li> <li>(i) publish guidelines, from time to time, on environmental aspects of processing and disposal of solid waste to enable local bodies to comply with the provisions of these rules; and</li> <li>(j) provide guidance to States or Union territories on inter-state movement of waste.</li> </ul> |
| State Government    | <ul style="list-style-type: none"> <li>- The SWM Rules, 2016 indicate that the Secretary-in charge of the Department of Urban Development or Local Self Government department of the concerned State or the Union territory, as the case may be, shall have the overall responsibility for the enforcement of the provisions of these rules in the metropolitan cities.</li> <li>- The Urban Development Department in charge of municipal authorities in the State or Union Territory shall:</li> </ul> <p>Clasue 11: Duties of the Secretary-in-charge, Urban Development in the States and Union territories.- (1) The Secretary, Urban Development Department in the State or Union territory through the Commissioner or Director of Municipal Administration or Director of local bodies shall:-</p>   |

**Table 1.2: Role of Central, State and Local Governments in Municipal Solid Waste Management [contd.]**

| LEVEL OF GOVERNMENT | ROLE  |
|---------------------|---|
|                     | <ul style="list-style-type: none"> <li>(a) prepare a state policy and solid waste management strategy for the state or the union territory in consultation with stakeholders including representative of waste pickers, self help group and similar groups working in the field of waste management consistent with these rules, national policy on solid waste management and national urban sanitation policy of the ministry of urban development, in a period not later than one year from the date of notification of these rules;</li> <li>(b) while preparing State policy and strategy on solid waste management, lay emphasis on waste reduction, reuse, recycling, recovery and optimum utilisation of various components of solid waste to ensure minimisation of waste going to the landfill and minimise impact of solid waste on human health and environment;</li> <li>(c) state policies and strategies should acknowledge the primary role played by the informal sector of waste pickers, waste collectors and recycling industry in reducing waste and provide broad guidelines regarding integration of waste picker or informal waste collectors in the waste management system.</li> <li>(d) ensure implementation of provisions of these rules by all local authorities;</li> <li>(e) direct the town planning department of the State to ensure that master plan of every city in the State or Union territory provisions for setting up of solid waste processing and disposal facilities except for the cities who are members of common waste processing facility or regional sanitary landfill for a group of cities; and</li> <li>(f) ensure identification and allocation of suitable land to the local bodies within one year for setting up of processing and disposal facilities for solid wastes and incorporate them in the master plans (land use plan) of the State or as the case may be, cities through metropolitan and district planning committees or town and country planning department;</li> <li>(h) direct the town planning department of the State and local bodies to ensure that a separate space for segregation, storage, decentralised processing of solid waste is demarcated in the development plan for group housing or commercial, institutional or any other non-residential complex exceeding 200 dwelling or having a plot area exceeding 5,000 square meters;</li> <li>(i) direct the developers of Special Economic Zone, Industrial Estate, Industrial Park to earmark at least five percent of the total area of the plot or minimum five plots or sheds for recovery and recycling facility.</li> <li>(j) facilitate establishment of common regional sanitary land fill for a group of cities and towns falling within a distance of 50 km (or more) from the regional facility on a cost sharing basis and ensure professional management of such sanitary landfills;</li> <li>(k) arrange for capacity building of local bodies in managing solid waste, segregation and transportation or processing of such waste at source;</li> <li>(l) notify buffer zone for the solid waste processing and disposal facilities of more than five tons per day in consultation with the State Pollution Control Board; and</li> <li>(m) start a scheme on registration of waste pickers and waste dealers.</li> </ul> |

**Table 1.2: Role of Central, State and Local Governments in Municipal Solid Waste Management [contd.]**

| LEVEL OF GOVERNMENT | ROLE   |
|---------------------|--|
|                     | <p>Clause:16: Duties of State Pollution Control Board or Pollution Control Committee.-</p> <p>(1) The State Pollution Control Board or Pollution Control Committee shall,-</p> <ul style="list-style-type: none"> <li>(a) enforce these rules in their State through local bodies in their respective jurisdiction and review implementation of these rules at least twice a year in close coordination with concerned Directorate of Municipal Administration or Secretary-in-charge of State Urban Development Department;</li> <li>(b) monitor environmental standards and adherence to conditions as specified under the Schedule I and Schedule II for waste processing and disposal sites;</li> <li>(c) examine the proposal for authorisation and make such inquiries as deemed fit, after the receipt of the application for the same in Form I from the local body or any other agency authorised by the local body;</li> <li>(d) while examining the proposal for authorisation, the requirement of consents under respective enactments and views of other agencies like the State Urban Development Department, the Town and Country Planning Department, District Planning Committee or Metropolitan Area Planning Committee, as may be applicable, Airport or Airbase Authority, the Ground Water Board, Railways, power distribution companies, highway department and other relevant agencies shall be taken into consideration and they shall be given four weeks time to give their views, if any;</li> <li>(e) issue authorisation within a period of sixty days in Form II to the local body or an operator of a facility or any other agency authorised by local body stipulating compliance criteria and environmental standards as specified in Schedules I and II including other conditions, as may be necessary;</li> <li>(f) synchronise the validity of said authorisation with the validity of the consents;</li> <li>(g) suspend or cancel the authorization issued under clause (a) any time, if the local body or operator of the facility fails to operate the facility as per the conditions stipulated: provided that no such authorization shall be suspended or cancelled without giving notice to the local body or operator, as the case may be; and</li> <li>(h) on receipt of application for renewal, renew the authorisation for next five years, after examining every application on merit and subject to the condition that the operator of the facility has fulfilled all the provisions of the rules, standards or conditions specified in the authorisation, consents or environment clearance.</li> </ul> <p>(2) The State Pollution Control Board or Pollution Control Committee shall, after giving reasonable opportunity of being heard to the applicant and for reasons thereof to be recorded in writing, refuse to grant or renew an authorisation.</p> <p>(3) In case of new technologies, where no standards have been prescribed by the Central Pollution Control Board, State Pollution Control Board or Pollution Control Committee, as the case may be, shall approach Central Pollution Control Board for getting standards specified.</p> |

**Table 1.2: Role of Central, State and Local Governments in Municipal Solid Waste Management [contd.]**

| LEVEL OF GOVERNMENT   | ROLE   |
|-----------------------|--|
|                       | <p>(4) The State Pollution Control Board or the Pollution Control Committee, as the case may be, shall monitor the compliance of the standards as prescribed or laid down and treatment technology as approved and the conditions stipulated in the authorisation and the standards specified in Schedules I and II under these rules as and when deemed appropriate but not less than once in a year.</p> <p>(5) The State Pollution Control Board or the Pollution Control Committee may give directions to local bodies for safe handling and disposal of domestic hazardous waste deposited by the waste generators at hazardous waste deposition facilities.</p> <p>(6) The State Pollution Control Board or the Pollution Control Committee shall regulate Inter-State movement of waste.</p>  |
| District/ Region      | <p>Clause 12: Duties of District Magistrate or District Collector or Deputy Commissioner.- The District Magistrate or District Collector or as the case may be, the Deputy Commissioner shall, -</p> <p>(a) facilitate identification and allocation of suitable land as per clause (f) of rules 11 for setting up solid waste processing and disposal facilities to local authorities in his district in close coordination with the Secretary-in-charge of State Urban Development Department within one year from the date of notification of these rules;</p> <p>(b) review the performance of local bodies, at least once in a quarter on waste segregation, processing, treatment and disposal and take corrective measures in consultation with the Commissioner or Director of Municipal Administration or Director of local bodies and secretary-in-charge of the State Urban Development.</p>  |
| Municipal Authorities | <p>As per the 74<sup>th</sup> CAA, the SWM Rules, 2016 and the State Municipal Laws, ULBs are primarily responsible for the provision of municipal solid waste management services.</p> <p>Clause 15: Duties and responsibilities of local authorities and village Panchayats of census towns and urban agglomerations.- The local authorities and Panchayats shall,-</p> <p>(a) prepare a solid waste management plan as per state policy and strategy on solid waste management within six months from the date of notification of state policy and strategy and submit a copy to respective departments of State Government or Union territory Administration or agency authorised by the State Government or Union territory Administration;</p> <p>(b) arrange for door to door collection of segregated solid waste from all households including slums and informal settlements, commercial, institutional and other non residential premises. From multi-storage buildings, large commercial complexes, malls, housing complexes, etc., this may be collected from the entry gate or any other designated location;</p> <p>(c) establish a system to recognise organisations of waste pickers or informal waste collectors and promote and establish a system for integration of these authorised waste-pickers and waste collectors to facilitate their participation in solid waste management including door to door collection of waste;</p> |

**Table 1.2: Role of Central, State and Local Governments in Municipal Solid Waste Management [contd.]**

| LEVEL OF GOVERNMENT | ROLE  |
|---------------------|---|
|                     | <p>(d) facilitate formation of Self Help Groups, provide identity cards and thereafter encourage integration in solid waste management including door to door collection of waste;</p> <p>(e) frame bye-laws incorporating the provisions of these rules within one year from the date of notification of these rules and ensure timely implementation;</p> <p>(f) prescribe from time to time user fee as deemed appropriate and collect the fee from the waste generators on its own or through authorised agency;</p> <p>(g) direct waste generators not to litter i.e throw or dispose of any waste such as paper, water bottles, liquor bottles, soft drink cans, tetra packs, fruit peel, wrappers, etc., or burn or burry waste on streets, open public spaces, drains, waste bodies and to segregate the waste at source as prescribed under these rules and hand over the segregated waste to authorised the waste pickers or waste collectors authorised by the local body;</p> <p>(h) setup material recovery facilities or secondary storage facilities with sufficient space for sorting of recyclable materials to enable informal or authorised waste pickers and waste collectors to separate recyclables from the waste and provide easy access to waste pickers and recyclers for collection of segregated recyclable waste such as paper, plastic, metal, glass, textile from the source of generation or from material recovery facilities; Bins for storage of bio-degradable wastes shall be painted green, those for storage of recyclable wastes shall be printed white and those for storage of other wastes shall be printed black;</p> <p>(i) establish waste deposition centres for domestic hazardous waste and give direction for waste generators to deposit domestic hazardous wastes at this centre for its safe disposal. Such facility shall be established in a city or town in a manner that one centre is set up for the area of twenty square kilometers or part thereof and notify the timings of receiving domestic hazardous waste at such centres;</p> <p>(j) ensure safe storage and transportation of the domestic hazardous waste to the hazardous waste disposal facility or as may be directed by the State Pollution Control Board or the Pollution Control Committee;</p> <p>(k) direct street sweepers not to burn tree leaves collected from street sweeping and store them separately and handover to the waste collectors or agency authorised by local body;</p> <p>(l) provide training on solid waste management to waste-pickers and waste collectors;</p> <p>(m) collect waste from vegetable, fruit, flower, meat, poultry and fish market on day to day basis and promote setting up of decentralised compost plant or biomethanation plant at suitable locations in the markets or in the vicinity of markets ensuring hygienic conditions;</p> <p>(n) collect separately waste from sweeping of streets, lanes and by-lanes daily, or on alternate days or twice a week depending on the density of population, commercial activity and local situation;</p> |

**Table 1.2: Role of Central, State and Local Governments in Municipal Solid Waste Management [contd.]**

| LEVEL OF GOVERNMENT | ROLE  |
|---------------------|---|
|                     | <ul style="list-style-type: none"> <li>(o) set up covered secondary storage facility for temporary storage of street sweepings and silt removed from surface drains in cases where direct collection of such waste into transport vehicles is not convenient. Waste so collected shall be collected and disposed of at regular intervals as decided by the local body;</li> <li>(p) collect horticulture, parks and garden waste separately and process in the parks and gardens, as far as possible; (q) transport segregated bio-degradable waste to the processing facilities like compost plant, biomethanation plant or any such facility. Preference shall be given for on site processing of such waste;</li> <li>(r) transport non-bio-degradable waste to the respective processing facility or material recovery facilities or secondary storage facility;</li> <li>(s) transport construction and demolition waste as per the provisions of the Construction and Demolition Waste management Rules, 2016;</li> <li>(t) involve communities in waste management and promotion of home composting, bio-gas generation, decentralised processing of waste at community level subject to control of odour and maintenance of hygienic conditions around the facility;</li> <li>(u) phase out the use of chemical fertilizer in two years and use compost in all parks, gardens maintained by the local body and wherever possible in other places under its jurisdiction. Incentives may be provided to recycling initiatives by informal waste recycling sector.</li> <li>(v) facilitate construction, operation and maintenance of solid waste processing facilities and associated infrastructure on their own or with private sector participation or through any agency for optimum utilisation of various components of solid waste adopting suitable technology including the following technologies and adhering to the guidelines issued by the Ministry of Urban Development from time to time and standards prescribed by the Central Pollution Control Board. Preference shall be given to decentralised processing to minimize transportation cost and environmental impacts such as-             <ul style="list-style-type: none"> <li>a) biomethanation, microbial composting, vermi-composting, anaerobic digestion or any other appropriate processing for bio-stabilisation of biodegradable wastes;</li> <li>b) waste to energy processes including refused derived fuel for combustible fraction of waste or supply as feedstock to solid waste based power plants or cement kilns;</li> </ul> </li> <li>(w) undertake on their own or through any other agency construction, operation and maintenance of sanitary landfill and associated infrastructure as per Schedule 1 for disposal of residual wastes in a manner prescribed under these rules;</li> <li>(x) make adequate provision of funds for capital investments as well as operation and maintenance of solid waste management services in the annual budget ensuring that funds for discretionary functions of the local body have been allocated only after meeting the requirement of necessary funds for solid waste management and other obligatory functions of the local body as per these rules;</li> <li>(y) make an application in Form-I for grant of authorisation for setting up waste processing, treatment or disposal facility, if the volume of waste is exceeding five metric tones per day including sanitary landfills from the State Pollution Control Board or the Pollution Control Committee, as the case may be;</li> </ul> |

**Table 1.2: Role of Central, State and Local Governments in Municipal Solid Waste Management [contd.]**

| LEVEL OF GOVERNMENT | ROLE  |
|---------------------|---|
|                     | <p>(z) submit application for renewal of authorisation at least sixty days before the expiry of the validity of authorisation;</p> <p>(za) prepare and submit annual report in Form IV on or before the 30th April of the succeeding year to the Commissioner or Director, Municipal Administration or designated Officer;</p> <p>(zb) the annual report shall then be sent to the Secretary -in-Charge of the State Urban Development Department or village panchayat or rural development department and to the respective State Pollution Control Board or Pollution Control Committee by the 31st May of every year;</p> <p>(zc) educate workers including contract workers and supervisors for door to door collection of segregated waste and transporting the unmixed waste during primary and secondary transportation to processing or disposal facility;</p> <p>(zd) ensure that the operator of a facility provides personal protection equipment including uniform, fluorescent jacket, hand gloves, raincoats, appropriate foot wear and masks to all workers handling solid waste and the same are used by the workforce;</p> <p>(ze) ensure that provisions for setting up of centers for collection, segregation and storage of segregated wastes, are incorporated in building plan while granting approval of building plan of a group housing society or market complex; and</p> <p>(zf) frame bye-laws and prescribe criteria for levying of spot fine for persons who litters or fails to comply with the provisions of these rules and delegate powers to officers or local bodies to levy spot fines as per the bye laws framed; and</p> <p>(zg) create public awareness through information, education and communication campaign and educate the waste generators on the following; namely:-</p> <ul style="list-style-type: none"> <li>(i) not to litter;</li> <li>(ii) minimise generation of waste;</li> <li>(iii) reuse the waste to the extent possible;</li> <li>(iv) practice segregation of waste into bio-degradable, non-biodegradable (recyclable and combustible), sanitary waste and domestic hazardous wastes at source;</li> <li>(v) practice home composting, vermi-composting, bio-gas generation or community level composting;</li> <li>(vi) wrap securely used sanitary waste as and when generated in the pouches provided by the brand owners or a suitable wrapping as prescribed by the local body and place the same in the bin meant for non- biodegradable waste;</li> <li>(vii) storage of segregated waste at source in different bins;</li> <li>(viii) handover segregated waste to waste pickers, waste collectors, recyclers or waste collection agencies; and</li> <li>(ix) pay monthly user fee or charges to waste collectors or local bodies or any other person authorised by the local body for sustainability of solid waste management.</li> </ul> |



**Table 1.2: Role of Central, State and Local Governments in Municipal Solid Waste Management [contd.]**

| LEVEL OF GOVERNMENT | ROLE  |
|---------------------|---|
|                     | <p>(zh) stop land filling or dumping of mixed waste soon after the timeline as specified in rule 23 for setting up and operationalisation of sanitary landfill is over;</p> <p>(zi) allow only the non-usable, non-recyclable, non-biodegradable, non-combustible and non-reactive inert waste and pre-processing rejects and residues from waste processing facilities to go to sanitary landfill and the sanitary landfill sites shall meet the specifications as given in Schedule-I, however, every effort shall be made to recycle or reuse the rejects to achieve the desired objective of zero waste going to landfill;</p> <p>(zj) investigate and analyse all old open dumpsites and existing operational dumpsites for their potential of bio- mining and bio-remediation and wheresoever feasible, take necessary actions to bio-mine or bio-remediate the sites;</p> <p>(zk) in absence of the potential of bio-mining and bio-remediation of dumpsite, it shall be scientifically capped as per landfill capping norms to prevent further damage to the environment.</p> |

#### 1.4.1.4.1 Guidance on State and Urban Local Body Institutional Linkages



Every state government and union territory shall constitute a state level advisory body through the urban development department within 6 months from the date of notification of SWM Rules, 2016. The state level advisory body shall meet at least once in 6 months to review all the matters related to implementation of SWM Rules, 2016 and implementation of state policy and strategy on MSWM, and to give advice to state government regarding necessary measures for expeditious and appropriate implementation of these rules. The copies of the review report shall be forwarded to all the prescribed authorities under the SWM Rules, 2016 for necessary action.

24. Annual report:-

- (1) The operator of facility shall submit the annual report to the local body in Form-III on or before the 30th day of April every year.
- (2) The local body shall submit its annual report in Form-IV to State Pollution Control Board or Pollution Committee and the Secretary-in-Charge of the Department of Urban Development of the concerned State or Union Territory in case of metropolitan city and to the Director of Municipal Administration or Commissioner of Municipal Administration or Officer in -Charge of Urban local bodies in the state in case of all other local bodies of state on or before the 30th day of June every year
- (3) Each State Pollution Control Board or Pollution Control Committee as the case may be, shall prepare and submit the consolidated annual

report to the Central Pollution Control Board and Ministry of Urban Development on the implementation of these rules and action taken against non complying local body by the 31<sup>st</sup> day of July of each year in Form-V.

- (4) The Central Pollution Control Board shall prepare a consolidated annual review report on the status of implementation of these rules by local bodies in the country and forward the same to the Ministry of Urban Development and Ministry of Environment, Forest and Climate Change, along with its recommendations before the 31<sup>st</sup> day of August each year.
- (5) The annual report shall be reviewed by the Ministry of Environment, Forest and Climate Change during the meeting of Central Monitoring Committee.

## 25. Accident reporting-



In case of an accident at any solid waste processing or treatment or disposal facility or landfill site, the Officer- in- charge of the facility shall report to the local body in Form-VI and the local body shall review and issue instructions if any, to the in- charge of the facility.

### 1.4.2 MUNICIPAL SOLID WASTE MANAGEMENT PLAN: LINK TO SERVICE LEVEL BENCHMARKS

As a part of the on-going endeavour to introduce greater accountability among urban local bodies to improve urban services, the MoUD has prepared Service Level benchmarks (SLBs) at the national level for service provision in 4 key sectors – water supply, sewerage, municipal solid waste management and storm water management. Devolution of the 13<sup>th</sup> Finance Commission Grants to ULBs has been linked to their assessment and achievement of SLBs.

Current SLBs and future targets for improved service levels are to be furnished annually by ULBs to the concerned departments in respective States and notified in the Gazette. Release of performance related grants is contingent on the assessment of SLBs by the concerned state level department and the MoUD. Service Level Benchmarking for all 4 core sectors is one of the nine reform conditions (condition no.8) stipulated by 13<sup>th</sup> Finance Commission, to be fulfilled by the States and Urban Local Bodies every year, starting from Financial Year 2010-11 to 2014-15.

Monitoring performance and improvements is envisaged as the goal of the Service Level Benchmarking programme. Benchmarking should be used as a tool for undertaking objective performance analysis by ULBs to improve their activities. The benchmarking of services enables state

ULBs should assess their current compliance with prescribed SLBs and should determine milestones for achieving identified targets within a specified timeline

level agencies and local level service providers to initiate a process of performance monitoring and evaluation against agreed targets.

The following SLBs have been developed by MoUD for measuring and monitoring provision of solid waste management services by ULBs.

**Table 1.3: Service Level Benchmarks for Solid Waste Management<sup>7</sup>**

| S.NO. | INDICATOR                                      | UNIT & DEFINITION  | VALUE |
|-------|--|--|-------|
| 1.    | Household level coverage of SWM services       | As % of households and establishments that are covered by daily doorstep collection system   | 100%  |
| 2.    | Efficiency of MSW collection                   | As % of total waste collected by ULB and authorized service providers versus the total waste generated within the ULB, excluding recycling or processing at the generation point | 100%  |
| 3.    | Extent of MSW segregation                      | As % of segregated waste from households and establishments (segregation should at least be at the level of separation of wet and dry waste at source)                           | 100%  |
| 4.    | Extent of recovered MSW                        | As % of waste collected (this is an indication of the quantum of waste collected, which is either recycled or processed)   | 80%   |
| 5.    | Extent of scientific disposal of MSW           | As % of waste disposed in a sanitary landfill sites versus total quantum of waste disposed in all sanitary landfills and dumping sites   | 100%  |
| 6.    | Efficiency in redressal of customer complaints | As % of total number of SWM related complaints resolved in 24 hours versus total number of SWM complaints received within the period   | 80%   |
| 7.    | Extent of cost recovery in SWM services        | As % recovery of all operating expenses related to SWM services that the ULB is able to meet from the operating revenues of sources related exclusively to SWM                   | 100%  |
| 8.    | Efficiency in collection of SWM charges        | Current year revenues collected as a % of the total operating revenues for the corresponding period  | 90%   |

Detailed guidance on the measurement and evaluation of the Service Level Benchmarks for SWM service provision are given in the SLB Handbook of the MoUD.

<sup>7</sup> "Handbook of Service Level Benchmarking", Ministry of Urban Development (2008).

### 1.4.3 STEP 2: ASSESSMENT OF CURRENT SITUATION OR STATUS AND GAP ANALYSIS

Figure 1.4: Step 2 in Municipal Solid Waste Management Plan

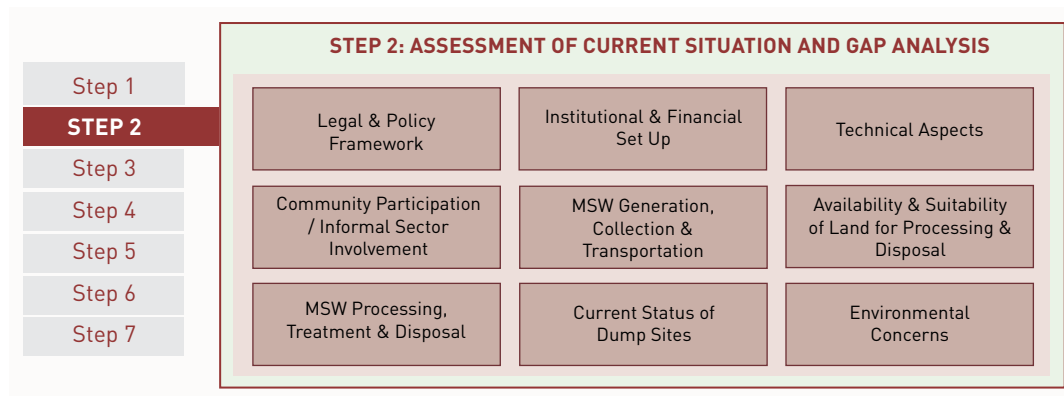

The MSWM department in the ULB should collect baseline information that needs to be assessed as indicated in Table 1.4. Baseline information shall be gathered from ward level records, citywide MSWM records, and field investigations as required (Figure 1.5).

Figure 1.5: An Overview of Baseline Information Required for Strategic Planning

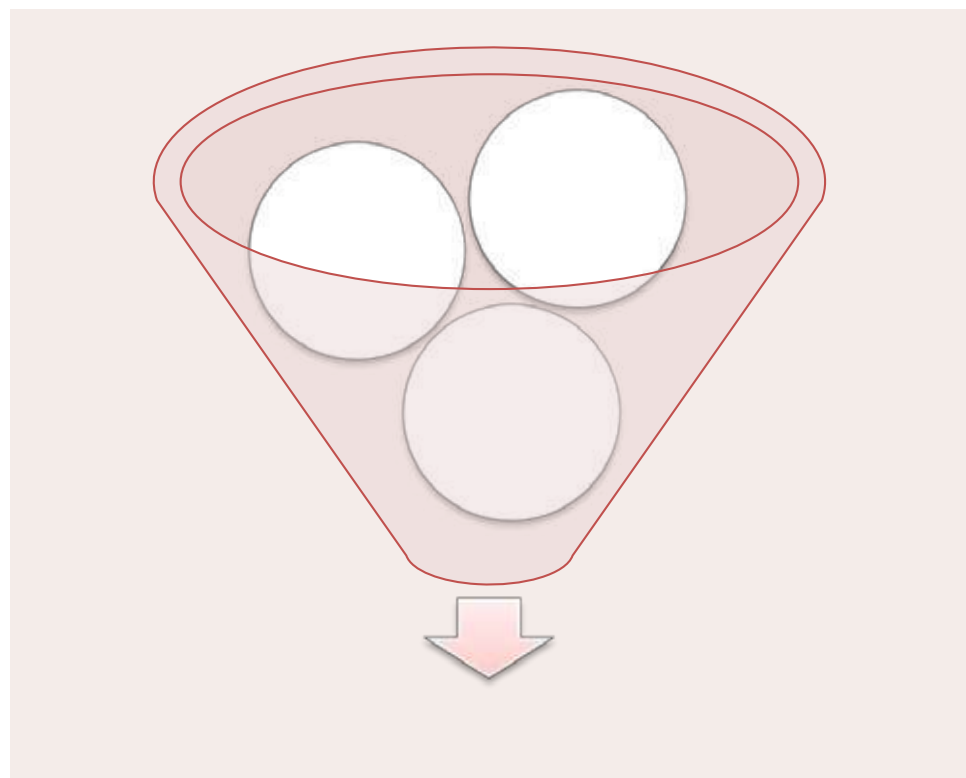

The main objective of the baseline study is to understand the existing solid waste system as accurately as possible; analyse system deficiencies in the context of SWM Rules, 2016; and utilise that information for further planning, implementation, and monitoring processes. Local conditions shall be considered while assessing the inadequacy of existing service and planning for the future with due consideration of local demography, physical location, growth objectives of the ULB, as well as social and environmental conditions.

### 1.4.3.1 GAP ANALYSIS

The assessment of information on the current status of waste management in the ULB in relation to the requirements of existing regulation, policies, guidelines, and identified service level benchmarks (SLBs) will result in an identification of key shortfalls in achieving the desired level of services and shall form the basis for preparing a plan to improve the MSWM system. Figure 1.6 illustrates a schematic diagram depicting the issues to be considered while assessing gaps in MSW service provision.

**Figure 1.6: Considerations for Gap Analysis**

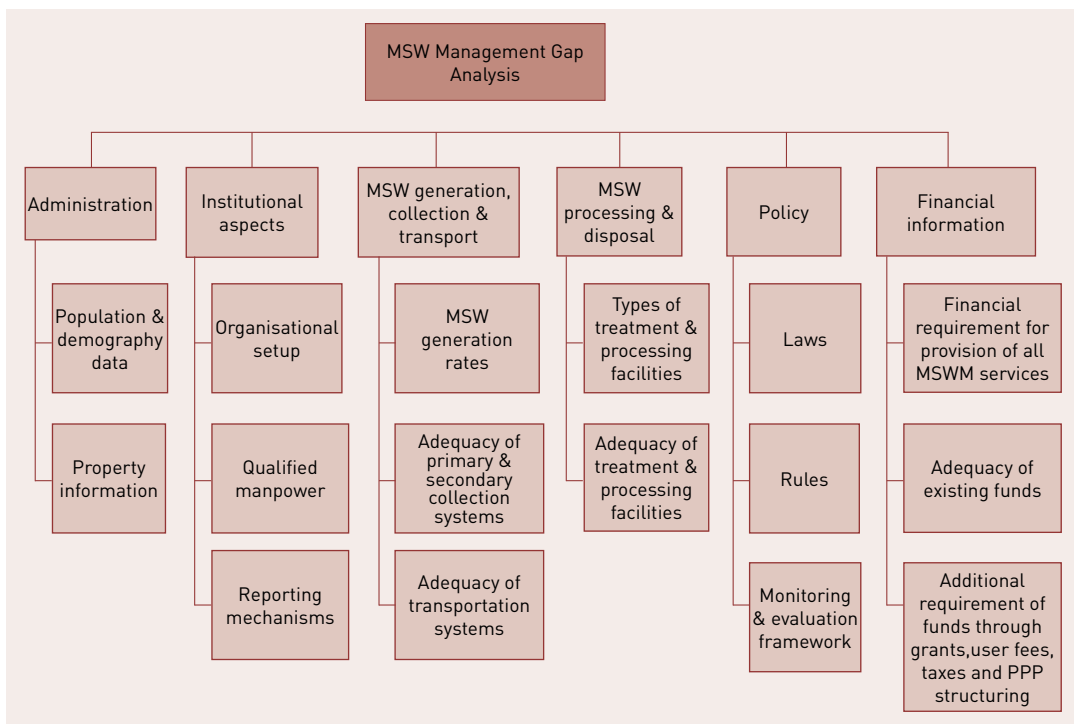

An indicative list of specific information to be collected and analysed for establishing the baseline of SWM service provision is given in Table 1.4.

**Table 1.4: Matrix for Collection of Baseline Information**  
(including statutory requirements as per SWM Rules, 2016 and SLBs)

| INFORMATION AT CITY LEVEL  | INFORMATION AT WARD LEVEL  | IDENTIFICATION OF STAKEHOLDERS   |
|--|--|--|
| <b>Administration</b>  |  |  |
| <ul style="list-style-type: none"> <li>Identify electoral and administrative wards and zones within the ULB</li> <li>Prepare a detailed city map showing total area in km<sup>2</sup>, ward boundaries, and city level demographic details, roads, drainage network, and land use pattern</li> <li>Depict on map areas served by door-to-door collection, community bin collection system, and areas not served</li> <li>Details of jurisdiction area and decadal growth of the city in the last 3 decades</li> <li>City level information on number of households, non-residential premises, institutional or bulk generators, industries and markets (information on a map)</li> <li>Number of election or administrative wards</li> <li>Details of existing monitoring and reporting system including a complaint redressal system</li> </ul>                                   | <ul style="list-style-type: none"> <li>Ward level population and demography details</li> <li>Number and location of slums (notified and non-notified) and their population</li> <li>Identify number of MSW generators in each ward (households, commercial establishments, institutional or bulk generators, industries, and markets) (information on a map)</li> <li>Details of existing monitoring and reporting system including a complaint redressal system</li> </ul>  |  |
| <b>Institutional Aspects</b>   |  |  |
| <ul style="list-style-type: none"> <li>Organisational structure of the ULB</li> <li>Organisational structure of SWM department in the city with full details of incumbents and their numbers, roles, and responsibilities</li> <li>Number and level of engineers with the municipal authority in relation to the SWM department</li> <li>Number and level of sanitary workers employed by the ULB for street cleaning, drain cleaning, transportation, processing and disposal of waste (regular and contractual)</li> <li>Provisions for workers (access to toilets, storage facility, linkages with community level crèches or anganwadis, PPE, etc.)</li> <li>Sweeper/road length ratio, sweeper/supervisor ratio, sweeper/population ratio, sweeper/bin ratio</li> <li>Details of MSWM tasks outsourced to external entities through various contracting procedures</li> </ul> | <ul style="list-style-type: none"> <li>Ward level human resources details</li> <li>Number of junior engineers at ward level</li> <li>Number of chief sanitary inspectors or officers</li> <li>Number of sanitary inspectors</li> <li>Number of sanitary supervisors</li> <li>Number of sanitary workers</li> <li>Provisions for workers (access to toilets, storage facility, linkages with community level crèches or anganwadis, PPE, etc.)</li> <li>Sweeper/road length ratio, sweeper/supervisor ratio, sweeper/population ratio, sweeper/bin ratio</li> <li>Details of MSWM tasks outsourced to external entities through various contracting procedures</li> </ul> | <ul style="list-style-type: none"> <li>Identification of operators in the city, extent of their coverage, the user fees levied by them, and level of their performance</li> <li>List of known recyclers in the ULB</li> <li>Approximate number of waste pickers and persons involved in the kabadi system within the ULB jurisdiction</li> <li>Identification of NGOs, voluntary groups, SHGs involved in SWM</li> </ul> |

**Table 1.4: Matrix for Collection of Baseline Information**  
(including statutory requirements as per SWM Rules, 2016 and SLBs) [contd.]

| INFORMATION AT CITY LEVEL   | INFORMATION AT WARD LEVEL  | IDENTIFICATION OF STAKEHOLDERS  |
|---|--|---|
| <b>Natural Environment</b>  |  |   |
| <ul style="list-style-type: none"> <li>• Climate, rainfall, temperature, wind speed and direction, dispersion conditions</li> <li>• Topography and drainage conditions</li> <li>• Land use and land cover</li> <li>• Soil type</li> <li>• Groundwater table</li> <li>• Surface water sources</li> <li>• Sensitive natural areas (mangroves, eco-sensitive zones)</li> </ul>   | <ul style="list-style-type: none"> <li>• Climate, rainfall, temperature, wind speed and direction, dispersion conditions</li> <li>• Topography and drainage conditions</li> <li>• Land use and land cover</li> <li>• Soil type</li> <li>• Groundwater table</li> <li>• Surface water sources</li> <li>• Sensitive natural areas (mangroves, eco-sensitive zones)</li> </ul>  |   |
| <b>MSW Generation, Collection and Transportation</b>  |  |   |
| <ul style="list-style-type: none"> <li>• Total quantity of waste generation, waste generation rates, seasonal fluctuations (TPD)</li> <li>• Total quantity of MSW collected (TPD)</li> <li>• Extent of population practicing waste storage at source and waste segregation</li> <li>• Extent of waste recycling or recovery</li> <li>• Per capita waste collected per day</li> <li>• Details of primary waste storage facilities</li> <li>• Number and type of community bins and secondary storage depots, their location, and type of waste collected (segregated or nonsegregated)</li> <li>• Coverage of population in daily street sweeping</li> <li>• Extent of coverage of slums and informal settlements</li> <li>• Waste transportation: number of vehicles and types of vehicles for primary, secondary, and tertiary transportation (differentiated for main waste types)</li> <li>• Details and route map for waste transportation in the city with identified service areas for different routes or vehicles or door-to-door collection beats (information to be marked on a map)</li> <li>• Number of trips made by vehicles in each shift</li> <li>• Quantity of solid waste transported by each vehicle</li> <li>• Percentage of waste collected each day</li> <li>• Frequency of collection from street bins</li> <li>• Number and identification of nuisance spots in the city where waste is indiscriminately disposed of (information to be marked on a map)</li> </ul> | <ul style="list-style-type: none"> <li>• Quantity and characteristics of waste generated and collected per ward</li> <li>• Waste quantities from different generators (residential, commercial, institutional, markets, bulk generators and businesses)</li> <li>• Quantity of construction and demolition waste</li> <li>• Quantity of E-Waste</li> <li>• Quantity of Plastic waste</li> <li>• Quantity of Biomedical waste</li> <li>• Status of at source waste collection</li> <li>• Door-to-door waste collection beat mapping (information to be marked on a map)</li> <li>• Door-to-door staffing involved</li> <li>• Waste collection frequency</li> <li>• Details of number and type of vehicles used for transportation and transportation routes (information to be marked on a map)</li> <li>• Number and identification of nuisance spots in the ward where waste is indiscriminately disposed of (information to be marked on a map)</li> </ul> | <ul style="list-style-type: none"> <li>• Role and extent of informal sector (waste pickers or kabadi system)</li> <li>• Involvement of RWAs or SHGs in collection of recyclables</li> <li>• Role of market associations</li> <li>• Role of institutions like universities, cantonments, government offices, etc.</li> <li>• Role of commercial enterprises, hotel associations, etc.</li> </ul> |

**Table 1.4: Matrix for Collection of Baseline Information**  
(including statutory requirements as per SWM Rules, 2016 and SLBs) [contd.]

| INFORMATION AT CITY LEVEL   | INFORMATION AT WARD LEVEL  | IDENTIFICATION OF STAKEHOLDERS  |
|---|--|---|
| <ul style="list-style-type: none"> <li>• Number and type of bins for secondary collection</li> <li>• Number and type of handcarts used for primary collection</li> </ul>  |  |   |
| <b>MSW Processing, Treatment and Disposal</b>   |  |   |
| <ul style="list-style-type: none"> <li>• Presence or absence of waste treatment or processing and disposal facilities in the ULB (location to be marked on a map)</li> <li>• Land available (location and area) for centralised and decentralised systems for processing and treatment</li> <li>• Land available (location and area) for sanitary landfill and dumping waste (marked on a map)</li> <li>• Technology adopted in each of the facilities</li> <li>• Percentage of MSW treated daily through the compost plants (decentralised and centralised), both windrow composting and vermicomposting</li> <li>• RDF plants</li> <li>• Waste to energy plants</li> <li>• Special waste treatment facilities, if any</li> <li>• Quantity and characterisation of waste treated or processed in each facility</li> <li>• Quantity of products sold from each treatment or processing facility</li> <li>• Total quantity of MSW disposed at sanitary landfill (TPD)</li> <li>• Total quantity of MSW disposed at dumpsite (TPD)</li> <li>• Quantity and characteristics of rejects from each facility and their disposal mechanism</li> <li>• Capacity, design life, technology, environmental management systems in each of the processing or treatment facility</li> <li>• Waste disposal methods adopted</li> <li>• Number of dumpsites and sanitary landfills (location on a map)</li> <li>• Sanitary landfill facilities and dumpsites - current capacity, waste disposed each day, expected life of landfill, landfill facilities (location on a map)</li> </ul> | <ul style="list-style-type: none"> <li>• Existing decentralised waste processing and/ or disposal systems, their size, and technology adopted (information to be marked on a map)</li> <li>• Reject management systems from decentralised facilities</li> <li>• Material recycling facilities</li> <li>• Land available (location and area) for decentralised processing and treatment (information on a map)</li> <li>• Land available (location and area) for dumping waste (location and area marked on a map)</li> </ul> | <ul style="list-style-type: none"> <li>• Private sector, NGOs or RWAs or SHGs, civil bodies, individuals involved in MSW processing at decentralised and centralised levels and extent of their coverage</li> </ul> |
| <b>Policy</b>   |  |   |
| <ul style="list-style-type: none"> <li>• Mandates or provisions of national, state, regional laws or rules, regulations, and policies related to MSWM and status of their implementation</li> <li>• Existing monitoring and evaluation mechanism for assessing MSWM</li> </ul>  | <ul style="list-style-type: none"> <li>• Ward level monitoring mechanism or regulations related to MSWM and status of their implementation</li> </ul>  |   |



**Table 1.4: Matrix for Collection of Baseline Information**  
(including statutory requirements as per SWM Rules, 2016 and SLBs) [contd.]

| INFORMATION AT CITY LEVEL  | INFORMATION AT WARD LEVEL   | IDENTIFICATION OF STAKEHOLDERS |
|--|---|--------------------------------|
| <b>Financial Information</b>   |   |                                |
| <ul style="list-style-type: none"> <li>Annual revenue and capital incurred by ULB for MSWM (direct expenditure and contracting costs)</li> <li>Costs per tonne of waste collected, treated, processed, and disposed</li> <li>User charge prescribed for door-to-door collection service revenues (demand and collection)</li> <li>Revenue generation from user charges or percent recovery</li> <li>Revenue generation from resource recovery</li> <li>Operation &amp; maintenance costs for MSWM</li> <li>Cost recovery for MSWM services</li> <li>Revenue generation from sale of products from various processing and treatment technologies</li> <li>Location and number of households paying user charges (location to be marked on a map)</li> </ul> | <ul style="list-style-type: none"> <li>User charge prescribed for door-to-door collection service revenues (demand and collection)</li> <li>Revenue generation from user charges or percent recovery</li> <li>Location and number of households paying user charges (location to be marked on a map)</li> </ul> |                                |

### 1.4.3.2 DATA COLLECTION METHODOLOGY

Detailed information for assessing the adequacy of MSWM services may not be readily available with the ULB. Collection of data mentioned in Table 1.4 could overburden smaller ULBs. Therefore, efforts may be made to collect secondary data from previous surveys or studies undertaken for other purposes. Some data may also be available with service providers, city planning departments, etc. Essential information may also be collected from field level supervisors after imparting requisite training on the type and manner of data to be collected from their respective wards.

Primary data shall be collected only when authentic secondary data is unavailable. Primary data may be collected through conducting surveys and measurements at the point of generation using data collection formats.

Availability of authentic data is a pre-requisite for strategic planning and implementation of MSWM Plan within a ULB

#### 1.4.3.2.1 Representative Data

Where the collection of primary data from the entire planning area is not possible, representative samples may be collected. The size of the representative sample shall be guided by consideration of the variations

in demography and income levels in constituent areas and seasonal variations.

### 1.4.3.3 QUANTIFICATION AND COMPOSITION OF WASTE

As an essential requirement each ULB should assess the quantity and composition of waste generated to plan for and design MSWM systems effectively. The quantity and composition of MSW generated in the ULB determine collection, processing, and disposal options that could be adopted. They are dependent on the population, demographic details, principal activities in the city or town, income levels, and lifestyle of the community.

Waste generation is strongly dependent on the local economy, lifestyle, and infrastructure. It has been well established that waste generation of an area is proportional to average income of the people of that area. It is also observed that generation of organic, plastic, and paper waste is high in high income areas.

An assessment states that the per capita waste generation is increasing by about 1.3% per year. With an urban growth rate of 3.0%–3.5% per year, the annual increase in waste quantities may be considered at 5% per year. Impacts of increasing ULB jurisdiction should also be considered while assessing future waste generation rates.

Several studies were conducted by Central Pollution Control Board (CPCB) over the last 2 decades to arrive at waste generation details and composition of MSW generated in the country. Summaries of the several findings are listed below:

- **1996:** The characterisation studies carried out by National Environmental Engineering Research Institute (NEERI) in 1996 indicate that MSW contains large organic fraction (30%–40%); ash and fine earth (30%–40%); paper (3%–6%); along with plastic, glass, and metal (each less than 1%). The calorific value of refuse ranges between 800 and 1,000 kilocalorie per kilogram (kcal/kg) and carbon-to-nitrogen (C/N) ratio ranges between 20 and 30. Study revealed that quantum of waste generation varies between 0.2 and 0.4 kg/capita/day in the urban centres and goes up to 0.5 kg/capita/day in metropolitan cities. The study was carried out in 43 cities of varying sizes, as detailed out in Table 1.5. The results were presented in a report published by NEERI “Strategy Paper on Solid Waste Management in India” (1996).

**Table 1.5: Per-capita Waste Generation Rates from NEERI Study in 1996<sup>8</sup>**

| POPULATION RANGE (IN MILLION) | NO. OF CITIES SURVEYED | AVERAGE PER CAPITA VALUE (KG/CAPITA/DAY) |
|-------------------------------|------------------------|--|
| 0.1 to 0.5                    | 12                     | 0.21                                     |
| 0.5 to 1.0                    | 15                     | 0.25                                     |
| 1.0 to 2.0                    | 9                      | 0.27                                     |
| 2.0-5.0                       | 3                      | 0.35                                     |
| >5.0                          | 4                      | 0.50                                     |

- **1999-2000:** The study conducted by CPCB through Environment Protection Training and Research Institute (EPTRI) in 1999–2000 in 210 Class I cities and 113 Class II towns indicated that Class I cities generated 48,134 tons per day (TPD) of MSW while Class II towns generated 3,401 TPD of MSW. The study revealed that waste generation rate in Class I cities was approximately 0.34 kg/capita/day while the waste generation rate in Class II towns was found to be 0.14 kg/capita/day.
- **2004-2005:** NEERI’s study “Assessment of Status of Municipal Solid Wastes Management in Metro Cities and State Capitals” in 2004–2005 assessed 59 cities (35 metro cities and 24 state capitals). Studies have revealed that waste generation rate varies from 0.12 to 0.60 kg/capita/day. Analysis of physical composition indicates that total compostable matter in the waste is 40%–60%, while recyclable fraction is 10%–25%. The moisture content in the MSW is 30%–60%, while the C/N ratio is 20–40.

It is essential to consider socio-economic conditions while planning, as they have a direct impact on per capita waste generation and composition.

**Table 1.6: Physical Composition of Municipal Solid Waste<sup>9</sup>**

| YEAR | COMPOSITION (%) |       |                |       |       |      |       |        |
|------|-----------------|-------|----------------|-------|-------|------|-------|--------|
|      | Biodegradables  | Paper | Plastic/Rubber | Metal | Glass | Rags | Other | Inerts |
| 1996 | 42.21           | 3.63  | 0.60           | 0.49  | 0.60  | -    | -     | 45.13  |
| 2005 | 47.43           | 8.13  | 9.22           | 0.50  | 1.01  | 4.49 | 4.016 | 25.16  |

- **2010-2011:** The survey conducted by the Central Institute of Plastics Engineering and Technology (CIPET) at the instance of CPCB has reported generation of 50,592 TPD of MSW in 2010–2011 in the same 59 cities.
- **2014-2015:** As per CPCB, 1,43,449 TPD of MSW was generated for 34 states and union territories during 2013–2014. The average rate of waste generation in India, based on this data, is 0.11 kg/capita/day. Out of the total waste generated, approximately 1,17,644 TPD (82%) of MSW was collected and 32,871 TPD (22.9%) was processed or treated.

<sup>8</sup> National Environmental Engineering Research Institute Study (1996).

<sup>9</sup> 'Improving Solid Waste Management in India', Zhu., D. et.al., [2008]. Available at: [http://www.tn.gov.in/cma/swm\\_in\\_india.pdf](http://www.tn.gov.in/cma/swm_in_india.pdf)

Other studies and observations indicate that waste generation rate is between 200 and 300 gm/capita/day in small towns and cities with a population below 2,00,000. It is usually 300–350 gm/capita/day in cities with a population between 2,00,000 and 5,00,000; 350–400 gm/capita/day in cities with a population between 5,00,000 and 10,00,000; and 400–600 gm/capita/day in cities with a population above 10,00,000. However, these are only indicative figures which need to be verified while planning city specific MSWM systems.

#### 1.4.3.3.1 Waste Quantification

**Current practice:** Waste generation rates are quantified by measuring the load of waste in collection vehicles either at a municipal or private weighbridge in the city. Alternately, the volumes of different vehicle used for transportation of waste are considered and a rule of thumb of 400–500 kilogram per cubic meter ( $\text{kg/m}^3$ ) is applied for determining the quantity of waste transported per trip per type of vehicle. A summation of the quantities of waste transported by each vehicle type multiplied by the total number of trips to the landfill by similar vehicles determines the total quantity of waste transported in the ULB. The practice of an eye estimate of waste quantity transported is not reliable as many times trucks carrying waste are half full or carry light material.



##### **Current Practice for Estimation of Quantity of Transported Waste**

Total Waste Collected = Quantity of Waste Transported by Each Vehicle x No. of Trips

The quantity of waste measured at transfer stations or processing or disposal sites also does not accurately reflect waste generation rates, since these measurements do not include:

- waste disposed at unauthorised places, vacant lots, alleys, ditches; etc.;
- waste recovered by kabadi system;
- waste recovered by informal waste collectors or waste pickers from the streets, bins, and intermediate transfer points, etc.

10 Adapted from "Strategic Planning Guide for Municipal Solid Waste Management". Environmental Resources Management (ERM), (2000), prepared for the World Bank, SDC and DFID by Waste-Aware, London; Available at: [http://www.worldbank.org/swm/erm/start\\_up.pdf](http://www.worldbank.org/swm/erm/start_up.pdf)



### Sampling for Waste Quantification

Municipal solid waste is very heterogeneous in nature and its composition varies with place and time. Even samples obtained from the same place (sampling point) on the same day, but at different times may show totally different characteristics.

**Long term Planning:** For the purpose of long term planning, the average amount of waste disposed by a specific class of generators can be estimated only by averaging data from several samples collected continuously for 7 days at multiple representative locations within the ULB jurisdiction in each of the 3 main seasons (summer, winter, and rainy seasons). Waste quantities should be aggregated over the 7-day period, weighed, and averaged. These quantities can then be extrapolated to the entire urban local body (ULB) and per capita generation assessed.

This should be repeated once every 3–5 years at the time of the review of the MSWM plan.

**Short term Planning:** Select at least 100 representative sampling locations per 1,00,000 population including households of low, mid, and high income levels; commercial establishments; institutional generators; hospitals and health care establishments; small and medium-sized enterprises; hotels; function halls; vegetable markets; sports complexes or facilities; places of worship (temples, mosques, etc.); and other significant representative groups. Storage bags sufficient for 3–7 days can be distributed to each waste generator who may be advised to deposit all waste generated daily in the given bag which is to be handed over to the specified waste collector on the subsequent day in the morning; the bags so distributed may be collected daily for a minimum of 3–7 days continuously and weighed immediately after collection using a sensitive weighing machine. Record may be kept of the waste generated by different categories of waste generators. The waste collected from each category may thereafter be mixed categorywise and segregated component-wise, and each component may be weighed separately to arrive at the waste composition in different categories of waste generators. This representative waste quantity and quality when extrapolated to the entire ULB and divided by the population will give the per capita waste generation rates.



### Quantifying Total Waste for Processing or Disposal

Municipal solid waste (MSW) in the Indian context does not include waste material such as newspapers, tins, bottles, etc. that are sold directly by waste generators to the informal sector and hence do not enter into the MSW stream.

Quantities of waste generated in the city need to be assessed to establish adequacy of existing systems and to plan for augmentation of treatment and disposal facilities. Waste moving through the system should be quantified at multiple locations to assess the actual quantities of waste available for processing and direct disposal.

Waste generated from households, markets, and other commercial establishments and institutions should be quantified; an appropriate sampling mechanism can be used (Sampling point A) given in the following figure. Entire waste collected from the city shall be weighed at weighbridges set up at transfer stations or en route to processing and disposal facilities.

### Waste Flow Diagram Depicting Points of Quantification<sup>10</sup>

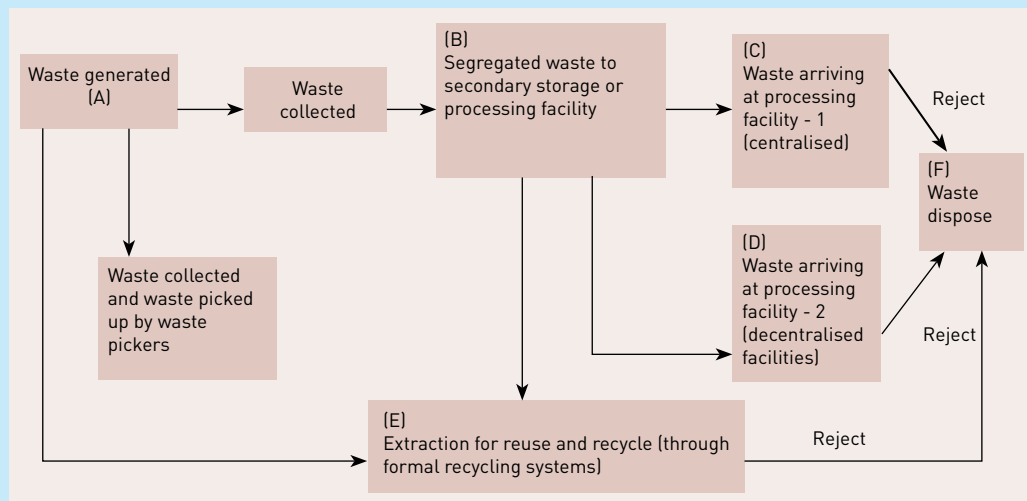

Larger cities may have more than one transfer station. In smaller cities where there may not be any transfer station, the processing and disposal facilities may be the first point where waste from the entire city is deposited. The sum of the waste quantities recorded at transfer points or the quantity of waste deposited directly at the processing facility and landfill site shall indicate the quantum of MSW that is to be handled by the ULB (Sampling point B) on a daily basis. This figure cannot be taken as waste quantity generated in the city, since certain quantity of waste is picked up from the system by the informal sector or waste pickers to earn their living, or by the agency entrusted with waste collection before the waste reaches the processing or disposal site. Besides, some percentage of waste is not collected at all due to system deficiencies.

The total waste generated in the city is a sum of waste deposited at the processing facility, directly at the landfill site, waste segregated en route to processing and disposal site, and the waste not collected at all. It is therefore difficult to arrive at an exact figure of waste generation in the city

The following should be noted:

- Based on the processing or treatment scheme selected, segregated waste streams may be sent to a single integrated waste management facility or more than one facility, each handling a specific waste stream. Waste quantities that are processed by each of such facilities shall be measured (e.g., Sampling points C, D, E, F in waste flow diagram).
- By subtracting quantity B from quantity A, quantification of waste not entering into the municipal waste management stream can be assessed (waste not collected, littered, picked up by waste picker, or bought up by informal sector at the generator).
- A weighbridge should be placed at a suitable location to weigh waste before being transferred to different treatment or processing and disposal facilities.
- Quantities of rejects that are being sent to the landfill facility from each of the processing facilities shall also be measured. For instance, in the waste flow diagram above, a weighbridge at an appropriate location may be used to quantify waste going to points B, C, D, and F. Waste collected by decentralized collection centres has to be weighed at the decentralized facility (point D).
- Cities with population less than 2,00,000 should tie up with private weighbridges for daily weighment of waste being managed by the ULB.



### 1.4.3.3.2 Determining Waste Composition

MSW composition and characteristics vary considerably, not only between cities but also within a ULB; daily, seasonal, and temporal fluctuations are usually observed. MSW is heterogeneous in nature and consists of varied waste fractions, requiring multiple samples at multiple locations.

The quartering and coning method (Figure 1.7) is one of the best techniques for determining the composition and characteristic of municipal waste. The sample is reduced to a more manageable size as the actual classification is carried out by hand.

Selection of sampling sites is a critical first step in this process. The following aspects shall be considered:

- Waste sampling sites and frequency of sampling shall be in accordance with guidance given in Section 1.4.3.3.1.
- The sample collection sites should be representative and include all major sources of waste generation including residential areas (including slums), commercial, business, and market areas (vegetable market, meat market, slaughterhouse, grain market, etc.).
- Sample sites should also be representative of all income groups within the ULB.

#### Quartering and Coning Sampling Procedure:

- Take 10 kg of municipal waste mixed from outside and inside of the waste pile, sourced from random entities in an identified sampling location.
- Samples from all heterogeneous sampling points shall be mixed thoroughly.
- The sample is placed as a uniform heap.
- The heap is divided into four portions using straight lines perpendicular to each other.
- Waste from opposing corners of the divided heap is removed to leave half of the original sample. The remaining portions are again thoroughly mixed and the quartering process is repeated until a desired size is obtained (10 kg of waste can be handled or segregated efficiently).
- The last remaining opposing fractions of waste shall be mixed and analysed for identifying physical and chemical properties of the waste.
- Chemical analysis of the waste sample follows the physical constituent analysis and shall be performed in a laboratory accredited by the Ministry of Environment, Forests and Climate Change (MoEFCC).<sup>11</sup>



Quartering and coning method is a well-established technique for waste characterisation

11 List of accredited laboratories by Ministry of Environment, Forests and Climate Change (MoEFCC), (2013); available at [http://www.envfor.nic.in/legis/env\\_lab.htm](http://www.envfor.nic.in/legis/env_lab.htm)

Figure 1.7: Characterisation of Municipal Solid Waste through Quartering Method<sup>12</sup>

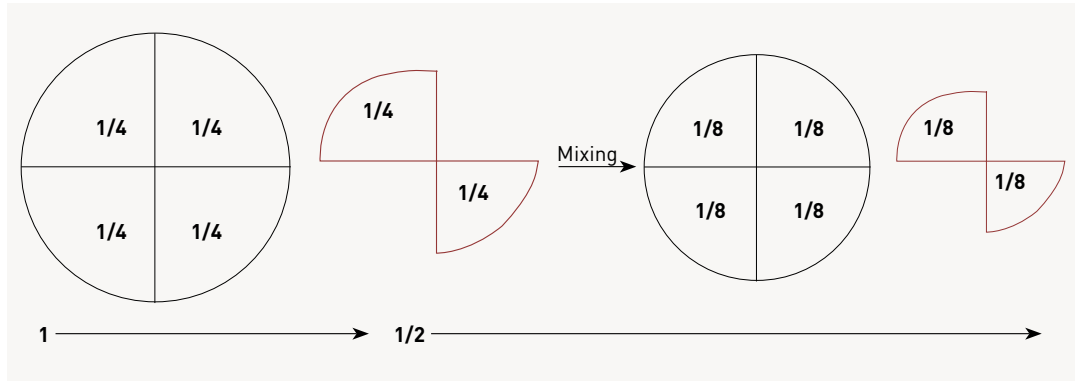

**Proportion of Waste Constituents:** The size distribution of waste constituents in the waste stream is important because of its significance on the selection of appropriate collection, transportation, processing, treatment, and disposal practices. The waste characterisation method mentioned above shall be followed to assess proportions of waste constituents.

### 1.4.3.3.3 Physical Characteristics of Municipal Waste

#### 1. Density of Waste

The density of waste (mass per unit volume,  $\text{kg/m}^3$ ) determines the storage and transportation volume requirements. MSW density in India is typically around  $450\text{--}500 \text{ kg/m}^3$ .

Critical parameters for selecting the appropriate processing technology are: waste quantity and characteristics, such as density, moisture, calorific value, toxicity etc.



#### Impact of Density on Waste Transportation Choices

The efficacy of using compactor bins and refuse compactors is dependent on the initial density of waste. Low density wastes (e.g., packaging wastes, plastic waste) may be hauled most efficiently through the use of compactors, where a compaction ratio as high as 2.5:1 is achievable. Compactors offer little or no advantage and are not cost-effective for transportation of wastes with high densities (e.g., street sweeping waste). In general, compactors may be used for all municipal wastes, except inert wastes.

#### Method for Bulk Density Measurement

Materials and Apparatus:

- Wooden box of  $1 \text{ m}^3$  capacity
- Wooden box of  $1 \text{ ft}^3$  capacity
- Spring balance weighing upto 50 kg.

<sup>12</sup> Adapted from "Toolkit for Solid Waste Management" JnNURM, (2012) and Manual on MSWM (First Edition), CPHEEO (2000) available at: <http://jnnurm.nic.in/toolkits-report-primers.html>



**Procedure:** A composite sample of MSW collected from different parts of the heap should be taken in the smaller 1 ft<sup>3</sup> box and weighed with the help of a spring balance. After weighing, contents of this smaller box (1 ft<sup>3</sup>) should be emptied into the bigger 1 m<sup>3</sup> box. This is repeated until the larger box is filled to the top. Once the larger box is filled, the weight of the waste is noted. The waste should not be compacted by pressure. Repeat the entire procedure thrice and take the average weight to arrive at the weight per cubic meter.

## 2. Moisture Content

Moisture content of MSW is usually expressed as the weight of moisture per unit weight of wet material.



$$\text{Moisture Content (\%)} = \frac{\text{Wet weight} - \text{dry weight}}{\text{Wet weight}} \times 100$$

*Note: Wet weight: initial weight of sample with moisture content*

*Dry weight: weight of the sample after drying the sample to remove moisture*

A typical range of moisture content is 20%–45%, representing the extremes of waste characteristics in an arid climate and in the wet season of a region having large precipitation. Values greater than 45% are however not uncommon. Moisture increases the weight of MSW, and therefore the cost of collection and transportation also increase. To prevent an increase in weight, waste should be insulated from rainfall or other extraneous water.

Moisture content is a critical determinant in the economic feasibility of incineration processes since energy (i.e., heat) must be supplied for evaporation of water and in raising the temperature of the water vapour. Moisture content is generally found to be high in wastes containing a higher proportion of food wastes.

## 3. Calorific Value

Calorific value of waste is defined as the amount of heat generated from combustion of a unit weight of the waste, expressed as kilojoule per kilogram (kJ/kg). The calorific value is determined experimentally using a bomb calorimeter, in which the heat generated from the combustion of a dry sample is measured at a constant temperature of 25°C. Since the test temperature is below the boiling point of water, the combustion water remains in the liquid state. However, during combustion the temperature of the combustion gases remains above 100°C, so that the water resulting from combustion is in the vapour state.

Municipal solid waste with high moisture content results in higher collection and transportation costs

Determining calorific value of waste is important to determine the potential for recovering RDF from waste and its utilisation in cement, power, and waste to energy plants

#### 4. Bio-Chemical Characteristics

Chemical characteristics of waste are essential in determining the efficacy of any treatment process.

- **Chemical characteristics:** These include pH; nitrogen, phosphorus, and potassium (N-P-K); total organic carbon; C/N ratio; and calorific value.
- **Biochemical characteristics:** These include carbohydrates, proteins, natural fiber, and biodegradable factor.
- **Toxicity:** Toxicity profile of MSW includes heavy metals, persistent organic pollutants, pesticides, and insecticides. Toxicity characteristic leaching procedure (TCLP) is used for ascertaining the toxicity profile of MSW.

Bio-chemical characteristics of waste determine the suitability of specific treatment processes. ULBs should use this information to select the most appropriate treatment process

#### 1.4.4 STEP 3: STAKEHOLDER CONSULTATION FOR MUNICIPAL SOLID WASTE MANAGEMENT PLANNING

Figure 1.8: Step 3 in the Municipal Solid Waste Management Plan



##### 1.4.4.1 DEPARTMENTS INVOLVED IN MUNICIPAL SOLID WASTE MANAGEMENT PLANNING (INTERNAL STAKEHOLDERS)

The main responsibility for preparing an MSWM plan lies with the ULB, specifically the SWM division. A core team or advisory team, also called the internal stakeholders, should be constituted for developing the MSWM plan.

##### 1.4.4.1.1 Plan Preparation – Core Team

The core team or internal stakeholder group consists of the following:

1. Commissioner or chief executive of the ULB
2. Head of the SWM department
3. Environmental engineer in the SWM department
4. Head of the town planning department

Pro-active involvement of internal and external stakeholders helps in developing an inclusive and strategic MSWM framework

5. Heads of the water supply, public health or sanitation, and sewerage departments
6. Head of the accounts department
7. Ward level officials in the SWM department, including sanitary inspectors, technical officers, and engineers

Specific responsibilities of each of these officials are given below:

- Commissioner or chief executive of ULB
  - Responsible and accountable for MSWM plan preparation and implementation
- Head of the MSW management department in the ULB
  - Responsible for establishing the baseline and analysing gaps in MSWM service provision
  - Responsible for coordinating various departments and stakeholders to be involved in development of MSWM plan
  - Responsible for assessing options and suggesting viable alternatives to be ratified by the stakeholders
- Environmental engineer (if appointed by the ULB) and ward level officials of the SWM department
  - Inform the planning process with field level consultations and information.
- Head of town planning department
  - Responsible for identifying viable locations for establishing SWM facilities and ensuring appropriate land use controls
- Heads of water supply, public health or sanitation, and sewerage departments
  - Explore potential cross-linkages and advise the MSWM plan process
- Head of accounts department.
  - Advice on potential revenues, costs, and implementing practices for appropriately recording SWM revenue and expenditure

Key persons to be consulted by core team before finalisation of the draft plan:

- Political head or mayor or chairman of ULB: Advising on the MSWM plan process with local level concerns and ensuring that the plan equitably addresses local MSWM issues

- Representatives of the SWM cell at the state level and CMA/DMA level to ensure that the planning process is in line with policies and strategies of the state, and to ensure the potential of exploring opportunities for regional level planning for MSWM service provision
- District magistrate or collector of the district in which the ULB is located: Responsible for allocation of land, ensuring implementation of regional level strategies, and identifying synergies with other ULBs in the region
- Representative from State Pollution Control Board: Responsible for ensuring compliance with SWM Rules, 2016 and compliance with other related statutory provisions for establishing and operating MSWM facilities
- Heads of concerned parastatal agencies related to urban service provision or city planning and land use issues

#### 1.4.4.1.2 Advisory Role

The municipal authority may also take advice from the following:

- Academicians and practicing professionals with SWM related expertise shall be involved.
- Where an environmental engineer is not hired by the ULB, an environmental engineer or planner may be co-opted in an advisory role.

#### 1.4.4.1.3 External Stakeholders

The first step for the local body is to define a methodology for reaching out to all stakeholders in an equitable manner at various stages of the MSWM planning and implementation. Informing and involving the community and creating channels for all stakeholders to participate in decision making are all very important steps for successful implementation of SWM strategies.

Typical stakeholders for an MSWM system include households, businesses, industries, informal sector, local government, NGOs, community-based organisations (CBOs), self-help groups (SHGs), women's groups, secondary school and college students, or members of other institutions who may have a role to play in ensuring the involvement of the community.

Stakeholders are to be consulted at least twice during the MSWM plan preparation, initially in defining the objectives and goals of the plan and later (Step 6) to discuss the proposed plan and seek their inputs



Stakeholder Consultations to be held at least twice while preparing the MWSM Plan

and approval. The ULB may constitute a stakeholder committee for the purpose, with members representing all concerned groups. These groups would need to represent the interest of men, women, youth, and marginalised or vulnerable groups who are all part of the MSWM process. Specifically, the involvement of women's groups during the planning phase is essential.

The initial consultation process (Step 3) should identify the following:

- the ability and willingness of stakeholders to cooperate in the operation and management of the service;
- the demand of stakeholders for different type of services like door to door collection, source segregation, etc., and frequency of service;
- their attitude toward participating in experiments or pilot projects, particularly projects relating to source segregation, reuse, recycling of waste, and final treatment and disposal;
- their willingness to work with different sections of society, such as waste pickers, municipal workers, and entrepreneurs; and
- their willingness to pay for the services, the mode of payment, and the frequency of payment.

#### **1.4.4.2 DEFINING THE GOALS AND OBJECTIVES OF THE MUNICIPAL SOLID WASTE MANAGEMENT PLAN**

Once the framework at national, state, and ULB level is defined and the stakeholders mapped, the next step will be for the ULB and the stakeholder group to define the goals and objectives of the MSWM plan.



A municipal solid waste management plan (also known as integrated municipal solid waste management plan) is a ratified document that defines the goals and objectives of municipal solid waste management, to be achieved over specific planning horizons and which gives details of specific actions that need to be implemented to meet these objectives.

## 1.4.5 STEP 4: PREPARATION OF DRAFT MUNICIPAL SOLID WASTE MANAGEMENT PLAN

Figure 1.9: Step 4: Preparation of Draft Municipal Solid Waste Management Plan

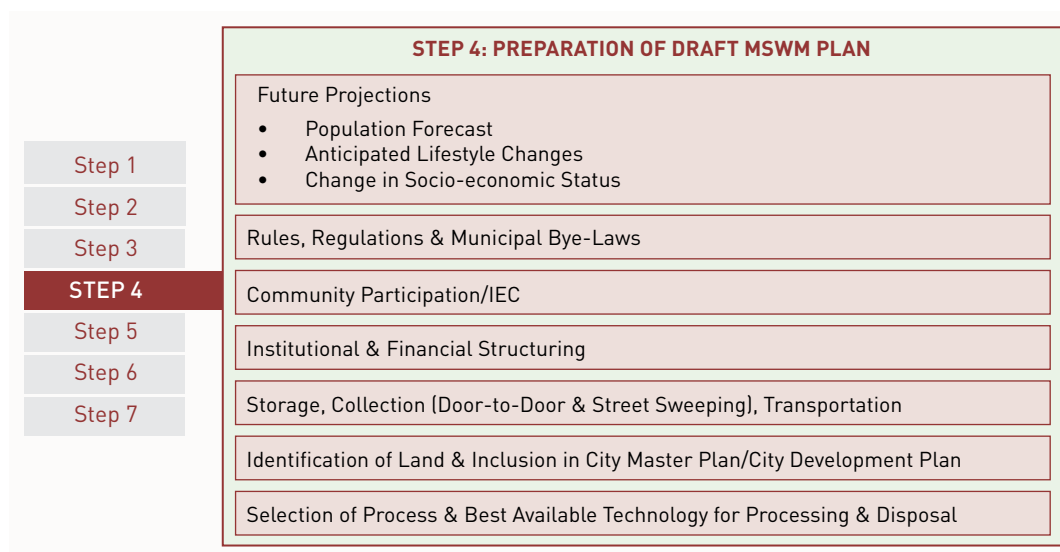

MSWM Plan should be integrated with local term development plans, National policies and strategies. It is desirable to review the plan once every 2-3 years

The MSWM plan cannot be developed in isolation. It has to consider objectives of other planning processes in force in the ULB. Objectives of the master plan and the city development plan shall be considered. Linkages with the city sanitation plans and National Urban Sanitation Policy (NUSP) shall also be ensured.

Depending on the existing plans for the urban area and the size of the area that the MSWM plan is prepared for, it is desirable to review the plan once every 2–3 years, with the objective of continuous improvement towards meeting service delivery standards.

The plan may be developed by considering several factors such as future population and waste generation projections, applicable laws and policies, institutional and financial structuring, inclusive and equitable community involvement, technical considerations in collection and transportation, availability of land, and best suited technologies for handling waste generated in the ULB, based on the ISWM hierarchy.

### 1.4.5.1 FUTURE PROJECTIONS

Estimating future waste generation quantities and composition is critical for developing MSWM plan. Planning horizons for MSW processing, treatment, or disposal projects typically extend to 20–30 years, depending on the nature of the facility. Forecasting future MSW generation is dependent on various factors, such as:

1. future population forecasts;
2. anticipated lifestyle changes; and
3. change in socio-economic profile of the ULB.

While preparing a MSWM plan, the following design periods (time-frame) have to be decided depending on the plan's necessity:

- (i) Short term plan: 5 years
- (ii) Long term plan: 20-25 years
- (iii) Mid term review between 2<sup>nd</sup> and 3<sup>rd</sup> year

Short term plan:  
5 years

Long term plan:  
20-25 years

Mid term review:  
between 2<sup>nd</sup> and  
3<sup>rd</sup> year

### 1.4.5.1.1 Forecasting Waste Generation



Future waste generation = Per capita waste generation x Projected population

### 1.4.5.1.2 Population Projection

Population projection is dependent on factors governing future growth and development in the considered jurisdiction. Growth in all development sectors should be considered. Special factors causing sudden immigration or influx of population should also be foreseen to the extent possible. Population growth can be estimated using multiple methods which are suited for cities of different sizes and stages of growth:

- i. **Arithmetic Increase Method:** If there has been a constant increase in population (in absolute numbers) over the past few decades, then for the purpose of future projection, arithmetic increase method could be used. In this method the increase of population per year/decade is calculated from past records and the average increase is added to the present population to find out population in next years/decade. This computation is suitable for historical, well settled and established cities.



### Population projection using the arithmetic increase method:

$$\text{Formula: } P = P_1 + k (t - t_1)$$

Arithmetic rate of growth:

$$K_a = \frac{P_2 - P_1}{t_2 - t_1}$$

P = population for projected year

P<sub>1</sub> = population in year a (base year)

P<sub>2</sub> = current population

t<sub>1</sub> = base year

t<sub>2</sub> = current year

t = period of the projection in decades

k = population growth rate (constant)

**Example:** If population of a city is 5,000 in 1971 and 7,050 in 2011, then projected population for 2021 is 7,563 (round off).

$$P_1 = 5,000$$

$$P_2 = 7,050$$

$$t_1 = 1971$$

$$t_2 = 2011$$

$$K = (7,050 - 5,000) / (2011 - 1971) = 51.25$$

$$P = 5,000 + (51.25) * (2021 - 1971) = 5,000 + 2562.5 = 7,562.5$$

Arithmetic increase method and geometrical increase method are the two most commonly used population projection methods

ii. **Geometrical Increase Method:** In this method the geometric mean of decadal averages is considered to be the rate of growth. This method is used for new and growing cities, which may have irregular growth patterns.

If the population growth rate is not available for a city, population growth trend has to be determined first. This could be done by comparing the population growth for the last 5 decades. If the decadal increase in population (in absolute numbers) is not constant, then the growth rate has to be determined first.







**Population projection using the geometrical increase method is calculated using the equation:**

$$\text{Formula: } P_b = P_a (1+r)t$$

$P_b$  = population of the year for which projection is to be made

$P_a$  = population of the base year

$r$  = the rate of growth divided by 100

$t$  = the number of years between 'a' and 'b'

**Example:** If population (2011) of a city is 1,000 with a growth rate of 1.8%, then projected population for 2021 is 1,195.

$$P_{2021} = P_{2011} \times (1 + 1.8/100)^{10}$$

$$= 1,000 \times 1.195$$

$$P_{2021} = 1,195$$

**In case decadal increase in population is not constant, then the growth rate has to be determined first**

Determination of Decadal Population Growth Rate (Geometric)

The population for (5 decades):

| YEAR | CENSUS POPULATION | GROWTH RATE |
|------|-------------------|-------------|
| 1971 | 5,000             |             |
| 1981 | 6,095             | 2%          |
| 1991 | 7,430             | 2%          |
| 2001 | 9,146             | 2.1%        |
| 2011 | 11,250            | 2%          |
| 2021 | 13,590            |             |

Formula for calculating growth rate:

$$r = \{(P_{1981} / P_{1971})^{1/t} - 1\} \times 100$$

(here  $t = 10$ )

$r$  = growth rate

After finding out the average growth rate (in percent), future projection could be done using the growth rate in the geometric increase method, as described above.

**iii. Incremental Increase Method:** In this method the increment in arithmetical increase is determined based on the past decades, and the average of that increment is added to the average increase.



**Population projection using the incremental increase method is calculated using the equation:**

$$\text{Formula: } P_n = P_0 + n_x + n(n+1)/2 \times Y \text{ where}$$

$P_n$  = Population after (n) decades from present (i.e last known census)

$P_0$  = Population in base year

$n$  = Period of projection in decades

$X$  = Average increase of population of known decades

$Y$  = Average of incremental increases of the known decades

- iv. **Graphical Method:** The graph between time and population is plotted from the available data and the curve is plotted. There are two approaches that could be adopted:
  - a. **Graphical method based on single city:** In this method the population curve of the city (i.e., present population vs. past decades) is smoothly extended for getting future value. This extension has to be done carefully. The line of best fit may be obtained by the method of least squares.
  - b. **Graphical method based on cities with similar growth pattern:** In this method the city in question is compared with other cities that have already undergone the same phases of development, which the city in question is likely to undergo. Based on this comparison, a graph between population and decades is plotted.
- v. **Decreasing Rate of Growth Method:** This method is applicable only in cases where the population growth rate shows a downward trend. In this method it is assumed that growth rate decreases, and the average growth rate decrease is calculated. Then the percentage increase is modified by deducting the decrease in growth rate.
- vi. **Logistic Method:** The ‘S’-shaped logistic curve for any city gives complete growth trend right from the beginning to the saturation limit of population.

#### **1.4.5.2 PER CAPITA WASTE GENERATION**

Per capita waste generation rates are to be established for each city based on the procedure specified in section 1.4.3.3.

#### **1.4.5.3 RULES, REGULATIONS AND MUNICIPAL BYE-LAWS**

The ULB shall consider all existing national and state rules and policies, identified in Step 1 and Step 2 of the planning process. Local bye-laws governing waste management, if any, shall also be considered. The framework for the plan shall be defined by these existing directives. The plan shall, at a minimum, seek to meet the objectives of all such policies and guidance. If applicable, due consideration shall be given to any legal directives on specific service provision, which may be time bound.

#### **1.4.5.4 PLANNING FOR AN INSTITUTIONAL STRUCTURE (TO BRIDGE THE GAPS)**

For planning an efficient and advanced MSWM system, it is essential to have an efficient institutional structure besides having adequate infrastructure and equipment. MSWM is both a managerial problem

and a technical issue. An effective institutional setup capable of designing, implementing, and monitoring the MSWM system needs to be established within the local authority. Currently, in many small and medium towns, sanitary inspectors look after MSWM. Whereas in many of the cities, the health officer, usually a medical doctor who does not have adequate exposure to technical and logistic practices in MSWM, heads the SWM department. It is therefore strongly recommended that ULBs should have an SWM cell or SWM department having staff with technical and managerial skills specific to MSW management.

The ULB shall follow their respective state government norms for staffing the SWM department (please refer to Annexure 2 for former Andhra Pradesh's staffing for SWM departments in ULBs).

However, in view of developments in the SWM sector, the Supreme Court then appointed an expert committee to look into all aspects of SWM. With a view to improve the situation, the Supreme Court's expert committee report on SWM recommended hiring professionals in MSW services to scientifically manage the waste issues. It is also recommended that in the cities where health officers are looking after MSWM or part thereof, in addition to their principal function of taking preventive health measures, they may be gradually made free from this responsibility and replaced by public health or environmental engineers.

The recommendations from the expert committee report are given below:

#### **1.4.5.4.1 Towns below 1 Lakh Population**

- One experienced Junior Engineer, if the population is more than 50,000 or in places with high floating population.
- One qualified sanitation diploma holder or Chief Sanitary Inspector or as Sanitary Officer if the population is more than 50,000.
- One qualified Sanitary Inspector per 50,000 population.
- One qualified Sanitary Sub-inspector per 25,000 population.
- One Sanitary Supervisor per 12,500 population.

#### **1.4.5.4.2 Cities between 1 and 2.5 Lakh Population**

- One experienced graduate engineer or Equivalent Health Officer.
- One experienced Junior Engineer per 1 lakh population.
- Qualified sanitation diploma holder Chief Sanitary Inspector or Sanitation Officer to look after the collection, transportation, processing and disposal of waste: 1 per 1 lakh population or part thereof; or 1 per 2 Sanitary Inspectors, whichever is less.



It is crucial to institutionalize within the ULB a dedicated SWM department or cell having staff with technical and managerial expertise specific to MSW management

- Qualified sanitation diploma holder Sanitary Inspector: 1 per 50,000 population or part thereof; or 1 per 80 sweepers, whichever is less.
- Qualified sanitation diploma holder Sanitary Sub-inspector: 1 per 25,000 population or part thereof; or 1 per 40 sweepers, whichever is less.
- Sanitary Supervisors (a person who can read, write, and report): 1 per 12,500 population or part thereof; or 1 per 20 sweepers, whichever is less.

#### **1.4.5.4.3 Cities between 2.5 and 5 Lakh Population**

- Public Health or Environmental Engineer or Civil Engineer having training in environmental or public health engineering in the Grade of Assistant Executive Engineer to be in charge of SWM department.
- Public Health or Environmental Engineer in the grade of Assistant Engineer to look after the transportation, processing and disposal of waste.
- One experienced Junior Engineer, per 2.5 lakh population.
- Chief Sanitary Inspector or Sanitary Officers to supervise storage, street sweeping, and primary collection of waste per 1 lakh population.
- Sanitary Inspectors, Sanitary Sub-inspectors, Sanitary Supervisors as per yardstick indicated in Section 1.4.5.4.2 above.

#### **1.4.5.4.4 Cities between 5 and 20 Lakh Population**

- Public Health or Environmental Engineer or Civil Engineer having training in environmental or public health engineering of the level of Executive Engineer to be in-charge of SWM department.
- Public Health or Environmental Engineer or Civil Engineer having training in environmental or public health engineering of the level of Assistant Executive Engineer per 5 lakh population.
- Public Health or Environmental Engineer or Civil Engineer having training in environmental or public health engineering of the level of Assistant Engineer per 2.5 lakh population.
- One experienced Junior Engineer, per 2.5 lakh population.
- Chief Sanitary Inspector or Sanitary Officers, Sanitary Inspectors, Sanitary Sub-inspectors and Sanitary Supervisors as per yardstick indicated in Section 1.4.5.4.2 above.

#### **1.4.5.4.5 Cities between 20 and 50 Lakh Population**

- Public Health Engineer or Environmental Engineer or Civil Engineer having training in environmental or public health engineering of the level of Superintending Engineer to be the Head of SWM Department.

- Public Health or Environmental Engineer or Civil Engineer having training in environmental or public health engineering of the level of Executive Engineer. One Executive Engineer per 20 lakh population or part thereof.
- Rest of the supervisors and staff as per the yardstick already indicated in Section 1.4.5.4.2 to 1.4.5.4.4 above.

#### 1.4.5.4.6 Cities above 50 Lakh Population

- Public Health Engineer or Environmental Engineer or Civil Engineer having training in environmental or public health engineering of the level of Chief Engineer to be in charge of SWM department.
- Superintending Engineer per 40 lakh population or part thereof.
- Rest of the officers, supervisor's etc. as per yardsticks already indicated in Section 1.4.5.4.2 to 1.4.5.4.5 above.



#### Health and Solid Waste Management Wings Differentiated in Andhra Pradesh

The Government of Andhra Pradesh, in order to focus on achieving the objectives of the Municipal Solid Waste (Management & Handling) Rules, 2000, has initiated several programs and initiatives. Strengthening capacity within urban local bodies (ULBs) to plan for and execute all actions along the solid waste management (SWM) chain has been given priority. The Commissioner & Director of Municipal Administration has issued orders in June 2013 to all district collectors and municipal commissioners to create two separate wings in the ULBs and to clearly demarcate the roles of health and SWM functionaries. Further, ULBs have been asked to stop outsourcing activities of the SWM and health departments, as these departments are now differentiated and are being staffed appropriately. Over 150 environmental engineer posts in various cadres have been sanctioned until 2013 to manage the SWM wing.

#### 1.4.5.5 TRAINING AND CAPACITY BUILDING

There is an urgent need to train and enhance the capacities of staff in MSWM activities. Professionalising the MSW sector will not only build the capacities of workers to perform more effectively and efficiently in the existing conditions, but will also inculcate a sense of responsibility and pride towards their profession. Provision of hygienic and safe working conditions for workers and encouraging the use of personal protective equipment (PPE) should also be part of this effort. The positive impact of such actions on the well-being of all workers (specifically the women) is far-reaching. These efforts will also lead to an improvement in service delivery and hence better management of activities.

It is important that the approach to capacity building in MSWM should not only focus on technology but also on different aspects including

Capacity building of staff is essential for enhancing their skills in monitoring MSWM service provision

governance, financing, planning, and improved service delivery. Figure 1.10 explains various capacity building approaches that can be adopted for different stakeholders based on the ULB's requirements.

**Figure 1.10: Capacity Building Approaches for Different Stakeholders<sup>13</sup>**

Training and capacity building activities for MSW staff include:

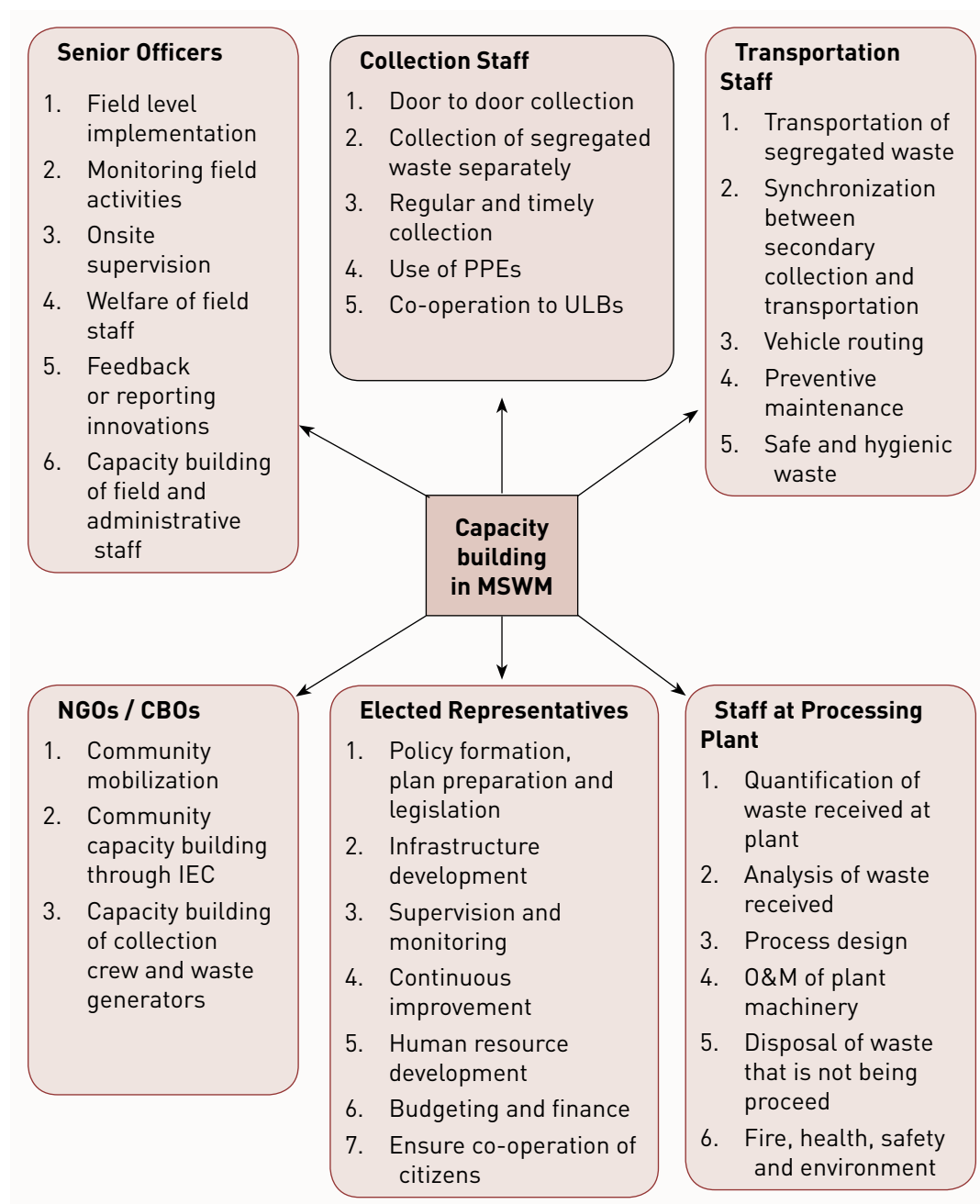

- **Special training:** The following should be trained: (i) unqualified staff and sanitation workers; (ii) ground level staff like sanitary supervisors (or equivalent); and (iii) sanitary inspectors, junior engineers, and senior officers. All officers and supervisors must be trained in skills required for an effective and efficient MSWM sector

<sup>13</sup> Toolkit for Solid Waste Management [2012], Jawaharlal Nehru National Urban Renewal Mission, Ministry of Urban Development, Government of India. <http://jnurm.nic.in/wp-content/uploads/2012/11/SWM-toolkit.pdf>

including instructing the sanitation workers. Best practices adopted by different cities in the state, country, and internationally should be made known to senior staff.

- **Refresher courses for supervisory staff:** Refresher courses should be conducted for officers and supervisors at least once every 5 years.
- **Study visits:** Learnings can be enhanced by visiting institutions or places where good practices have already been well established.
- **Professional growth opportunities:** Adequate professional growth opportunities should be built into the MSWM hierarchy to encourage supervisory staff members to remain in the department and hence avoid attrition.

### 1.4.5.6 FINANCIAL IMPLEMENTATION STRUCTURE

#### 1.4.5.6.1 Overall Cost Assessment (Full Cost Assessment)

The planning for an advanced MSWM system should be based on accurate financial calculations, taking into consideration all relevant costs including hidden costs and revenues. This important task within the planning process is to ensure financial viability of the MSWM system and its sustainability in the long run.<sup>14,15</sup>

ULBs generally fund their MSWM activities through a combination of government grants and internal revenues from property tax and non-tax revenues; some ULBs finance projects through public private partnership (PPP) arrangements. Very few ULBs resort to taking loans for MSWM services. Revenues from MSWM service provision and expenditure on various components of MSWM are usually not properly accounted for. Segregated financial information pertaining to MSWM service is required to assess the financial viability of service provision.

Full cost accounting (FCA) (Figure 1.11) provides a systematic framework for identifying and evaluating all costs associated with the integrated waste management options for ULBs as mentioned above.

- **Front-end costs:** These include the pre-operative investments and expenses necessary to implement MSW services.
- **Capital costs:** These include one-time fixed costs for plant and machinery and any cost of capital.
- **Operating costs:** These include daily expenses of managing MSW, refurbishment costs, and operation and maintenance (O&M) costs.

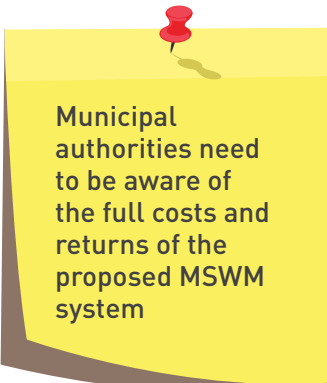

Municipal authorities need to be aware of the full costs and returns of the proposed MSWM system



MSWM services are traditionally financed through a combination of government grants and revenues

14 "Full Cost Accounting for Municipal Solid Waste Management: A Handbook", EPA, (1997), available at: <http://www.epa.gov/waste/conserve/tools/fca/docs/fca-hanb.pdf>

15 "Analysis of the Full Costs of Solid Waste Management for North Carolina Local Governments", DEHNR, (1997), available at <http://infohouse.p2ric.org/ref/01/00369.pdf>

- **Back-end costs:** These comprise expenditure required to wrap up O&M of MSW facilities at the end of their useful lives.
- **Contingent costs:** These include costs that might or might not be incurred at some point in the future, e.g., remediating future release of pollutants.
- **Environmental costs:** These are the implications on the environment that might occur due to MSW transportation, treatment, and disposal activities (e.g., costs for mitigating contaminated soil, polluted surface and groundwater bodies, and poor air quality due to indiscriminate burning of MSW).
- **Social costs:** These are costs incurred to mitigate adverse impacts on health and well-being of local community, on account of improper MSWM. In India, such impacts are generally not compensated. Impacts of MSW storage depots, as well as MSW treatment and disposal facilities on the health, quality of life, and value of property in the neighbourhood are considered. An assessment and consideration of these impacts is required before selecting waste management options, even though they are not easily quantifiable.

**Figure 1.11: Elements of Full Cost Accounting**

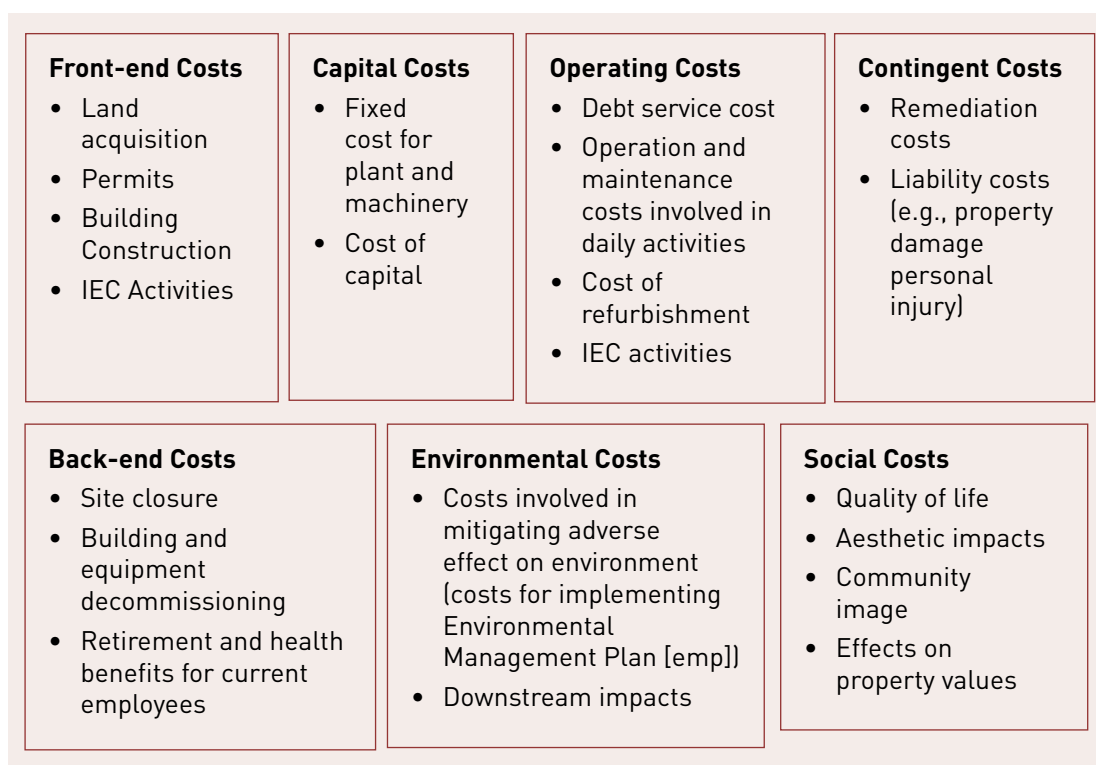

FCA reflects the real costs of the MSWM system:

- Front-end costs
- Capital costs
- Operating costs
- Contingent costs
- Back-end costs
- Environmental costs
- Social costs

These categories together cover the life cycle of MSW activities from the “cradle” (Front-end costs) to “grave” (back-end costs). FCA provides accurate and complete information on the real costs of managing municipal solid waste. It tends to uncover hidden and overlooked costs and allocates all costs to the specific activity. This helps decision-makers



to compare present and proposed services accurately, predict future costs reliably and evaluate privatisation options thoroughly.

### Other Advantages of Full Cost Accounting

- ULBs can use FCA as a planning tool for preparing budgets and determining future direction.
- FCA helps the ULBs to examine various financial scenarios and their resulting impacts in the future.
- FCA can also be used while analysing costs in the long term.
- FCA results can also be used for maintaining transparency between the ULBs and the general public. The results can be presented to the public through media (e.g., newspaper). However, FCA does not address non-monetary costs and benefits like social costs and public expectations. Results from FCA should be considered in conjunction with non-monetary costs to help ULBs to make better informed decisions for MSWM.

**Description of elements of full cost assessment:** The following section provides schemes on how to calculate and document the total costs of a stand-alone fully compliant MSWM system.

**Front-end Costs:** Front-end costs include pre-operative activities that are required before implementing any MSWM system (e.g., investigation costs such as topographical surveys; geotechnical, geological, hydrogeological investigations; environment impact assessment; etc.). Table 1.7 gives an overview of front-end costs involved in a typical MSWM system.

**Table 1.7: Indicative Front-end Costs in a Typical Municipal Solid Waste Management System**

| SL. NO | DESCRIPTION                     | NOS. | UNIT RATE | AMOUNT |
|--------|---------------------------------|------|-----------|--------|
| 1      | Obtaining permit for land       |      |           |        |
| 2      | Topographical survey            |      |           |        |
| 3      | Geotechnical investigation      |      |           |        |
| 4      | Geological investigation        |      |           |        |
| 5      | Hydrogeological investigation   |      |           |        |
| 6      | Waste characterisation          |      |           |        |
| 7      | Waste quantification            |      |           |        |
| 8      | Detailed design                 |      |           |        |
| 9      | Environmental impact assessment |      |           |        |
| 10.    | Others                          |      |           |        |

**Capital Costs:** Capital costs are one-time fixed costs associated with a project which may include the price of purchased assets such as land, vehicles, equipment, or other supplies. The capital costs involved in MSWM systems can be further divided based on activities:

- **Collection and transportation costs:** These include purchase of collection tools, storage bins, transportation vehicles, construction of transfer stations. An indicative format for assessing capital costs for collection and transportation is given in Table 1.8.
- **Processing and disposal costs:** These include cost of land buildings, plant machinery, process equipment, material handling equipment, pollution control equipment (electrostatic precipitators, bag filters, and other dust control equipment), transport vehicles, material recovery facilities, construction of sanitary landfill, laboratory facilities, rainwater drainage management, electrical equipment, backup of power, green belt, etc. An indicative format for assessing capital costs for processing and disposal is given in Table 1.9.

**Table 1.8: Indicative Format for Assessing Capital Costs for Collection and Transportation System for Municipal Solid Waste Management**

| S. NO | DESCRIPTION  | DTD | SS & DC | SC & T | CM | TOTAL (A) | 15% CON- TINGENCY (B) | UNIT RATE (INR) (A+B) | AMOUNT |
|-------|--|-----|---------|--------|----|-----------|-----------------------|-----------------------|--------|
| 1     | Pushcart bins (6 per pushcart)                         |     |         |        |    |           |                       |                       |        |
| 2     | Pushcarts  |     |         |        |    |           |                       |                       |        |
| 3     | Tricycle   |     |         |        |    |           |                       |                       |        |
| 4     | Tricycle bins (8 per tricycle)                         |     |         |        |    |           |                       |                       |        |
| 5     | Auto tipper (1 m <sup>3</sup> )                        |     |         |        |    |           |                       |                       |        |
| 6     | Metal tray, metal plate                                |     |         |        |    |           |                       |                       |        |
| 7     | Tipper trucks  |     |         |        |    |           |                       |                       |        |
| 8     | 1.0 m <sup>3</sup> container with strips (dumper bins) |     |         |        |    |           |                       |                       |        |
| 9     | 3.0 m <sup>3</sup> skips (dumper bins)                 |     |         |        |    |           |                       |                       |        |
| 10    | 4.5 m <sup>3</sup> skips (dumper bins)                 |     |         |        |    |           |                       |                       |        |
| 11    | Dumper placers   |     |         |        |    |           |                       |                       |        |
| 12    | Refuse compactors                                      |     |         |        |    |           |                       |                       |        |
| 13    | Drain cleaning or jetting machine                      |     |         |        |    |           |                       |                       |        |
| 14    | Mechanized sweeper trucks (large or small)             |     |         |        |    |           |                       |                       |        |
| 15    | Others   |     |         |        |    |           |                       |                       |        |

(DTD: Door to Door, SS&DC: Street Sweeping and Drain Cleaning, SC&T: Street Collection and Transportation, CM: Cleaning of Markets)

**Table 1.9: Indicative Format for Assessing Capital Costs for Establishing Processing and Disposal Systems for Municipal Solid Waste Management**

| S.NO. | DESCRIPTION  | NOS. | UNIT RATE | AMOUNT |
|-------|--|------|-----------|--------|
| 1     | Land   |      |           |        |
| 2     | Buildings  |      |           |        |
| 3     | Process equipment (trommel, sieves, separators)      |      |           |        |
| 4     | Material handling (conveyors, loaders, elevators)    |      |           |        |
| 5     | Pollution control equipment                          |      |           |        |
| 6     | Transport (tippers, tractors)                        |      |           |        |
| 7     | Material recovery facility                           |      |           |        |
| 8     | Sanitary landfill                                    |      |           |        |
| 9     | Rainwater management (drains, ponds)                 |      |           |        |
| 10    | Diesel Generator set, transformer yard, cables       |      |           |        |
| 11    | Weighbridge  |      |           |        |
| 12    | Security   |      |           |        |
| 13    | Office, management information system, or laboratory |      |           |        |
| 14    | Others   |      |           |        |

**Operation & Maintenance Cost:** Operations and maintenance (O&M) cost is an ongoing cost and shall include all costs incurred in daily operation of the facility. It shall include labour and salaries; administrative and management cost; maintenance of vehicles and equipment; fuel or tyres; etc. Table 1.10 gives an overview of estimated O&M cost incurred in MSWM.

**Table 1.10: Indicative Format for Assessing Capital Costs for Collection and Transportation System for Municipal Solid Waste Management**

| S.NO | DESCRIPTION   | QUANTITY | UNIT RATE (RS) | TOTAL AMOUNT (RS) |
|------|---|----------|----------------|-------------------|
| I    | Collection and transportation vehicles and equipment                          |          |                |                   |
|      | All equipment (metal tray, brooms, personal protective equipment [PPE], etc.) |          |                |                   |
|      | Fuel  |          |                |                   |
|      | Vehicle maintenance cost (%) of vehicle cost                                  |          |                |                   |
|      | Cost of spares, tires, etc.   |          |                |                   |
|      | Others  |          |                |                   |

**Table 1.10: Indicative Format for Assessing Capital Costs for Collection and Transportation System for Municipal Solid Waste Management [contd.]**

| S.NO   | DESCRIPTION   | QUANTITY | UNIT RATE (RS) | TOTAL AMOUNT (RS) |
|--------|---|----------|----------------|-------------------|
| II     | Salaries of workers for collection and transportation   |          |                |                   |
|        | Supervisor  |          |                |                   |
|        | Sweepers, loaders, sanitary workers                     |          |                |                   |
|        | Driver  |          |                |                   |
|        | Others  |          |                |                   |
| III    | Salaries of workers at processing and disposal facility |          |                |                   |
|        | Plant in charge   |          |                |                   |
|        | Plant supervisors                                       |          |                |                   |
|        | Fitters   |          |                |                   |
|        | Electrician   |          |                |                   |
|        | Vehicle maintenance-in-charge                           |          |                |                   |
|        | Stores-in-charge  |          |                |                   |
|        | Landfill-in-charge                                      |          |                |                   |
|        | Weighbridge operator                                    |          |                |                   |
|        | Office-in-charge  |          |                |                   |
|        | Yard operation-in-charge                                |          |                |                   |
| Others |   |          |                |                   |
| IV     | Salaries of laboratory staff                            |          |                |                   |
|        | Quality assurance chemist                               |          |                |                   |
|        | Other lab staff   |          |                |                   |
|        | Others  |          |                |                   |
| V      | PPE   |          |                |                   |
|        | Face mask   |          |                |                   |
|        | Gum boot  |          |                |                   |
|        | Hand gloves   |          |                |                   |
|        | Uniform   |          |                |                   |
|        | Others  |          |                |                   |

Some of the other costs that need to be considered are:

- **Working capital costs:** These include interest on at least 2 months receivables and revenue from tipping fee, electricity sale, compost sale, and any other product sold. In addition, at least 2 months O&M costs have to be built in.
- **Finance costs:** These include depreciation, interest on debt, income taxes, sinking fund for refurbishment, insurances, bank guarantees, post-closure monitoring, etc.

### 1.4.5.6.2 Financial Viability of Municipal Solid Waste Management System

MSWM should be planned in a manner that it meets all statutory requirements. The level of sophistication could vary depending on the financial capability of the municipal authority. Sustainable design and implementation of systems should be ensured. MSWM projects should be made viable by ensuring cost recovery through levy of user fees from the beneficiaries, prescribing appropriate fees or tipping fees for the services rendered, sale of end products from the processing of waste, allocation of funds from municipal internal resources and government grants, viability gap funding from the government (if any), and introducing public private partnerships (PPPs) for efficiency and attracting private sector investments.

MSWM services are sustainable only if they are financially viable on a stand-alone basis. Therefore, the assessment of financial viability is an important step in planning MSWM system. The deficit in funding planned services, if any, should be estimated. Table 1.11 gives a format for assessing deficits over a time period.

**Table 1.11: Format for Assessing Financial Deficits for Provision of Municipal Solid Waste Management Services**

| S. NO | DESCRIPTION                  | YEAR 01 (RS) | YEAR 02 (RS) | YEAR 03 | YEAR.... | YEAR 20 (RS) |
|-------|------------------------------|--------------|--------------|---------|----------|--------------|
| 1     | Total cost                   |              |              |         |          |              |
| 2     | Revenue                      |              |              |         |          |              |
|       | Deficit (total cost-revenue) |              |              |         |          |              |

### 1.4.5.6.3 Identification of Sources for Finance

The extent of service provision by the ULBs is determined largely by the availability and allocation of finances to different services and functions. ULBs are empowered to derive their income from several sources such as taxes, fines, penalties, and remunerative enterprises. Apart from the above mentioned sources, ULBs also depend on grants and loans to meet their financial needs.<sup>16,17</sup>

The traditional sources of financing MSWM activities include:

- local taxes, e.g., property tax, water tax, conservancy tax, development fee, etc.;

16 "Environmental Fiscal Reforms in India: Where and How?", GIZ and TERI (2011).

17 "Economic Instruments in the Waste Management Sector", GIZ (2010).

Available at: <http://www.giz.de/de/downloads/gtz2010-en-foes-economic-instruments-waste-management.pdf>



Financial viability of the MSWM Plan can be ensured through consideration of several cost recovery mechanisms: user fees, sale of end products, municipal funds and grants from State and Central Governments, loans and funding from private sector through PPPs

Variable user charges are based on the quantity of waste generated and the level of service provision



To enhance the tax base cross subsidisation and higher charges for commercial, bulk generators etc. should be considered. Moderate rate, least exemptions and wider coverage of all classes of tax payers will fetch higher revenues

- user charges;
- rents from properties, license fees, and other non-tax revenues;
- grants from state and central government, e.g., Swachh Bharat Mission, state finance commission grants;
- loans from capital market, government, and financial institutions, e.g., Housing and Urban Development Corporation (HUDCO) and National Bank for Agriculture and Rural Development (NABARD);
- loans from international agencies, e.g., Asian Development Bank (ADB), Japan Bank for International Cooperation (JBIC), German Development Bank (KfW) and the World Bank;
- PPPs;
- Municipal bonds or debentures;
- revenue from sale of products from waste processing plants (if owned by the ULB);
- tipping fees from the private operator.

#### (a) Property Taxes

Traditionally, property tax in India is the single largest internal source of revenue to the ULBs, contributing as much as 25%–30% to their total revenue. Government grants are another major source of revenue, mainly utilised for paying wages to employees and for undertaking specific projects. Most of the ULBs use a sizable part of the property tax to support MSWM activities. However, since the assessment and collection of property tax is poor, ULBs are unable to allocate adequate funds for MSWM services. Further, the lumpsum approach of the property tax does not impose any incentive for at-source waste minimisation as discussed in Section 2.1 of Part II. Rationalisation of the property tax is required to ensure financial sustainability of these services.

#### (b) User Charges<sup>18</sup>

The following basic principles may be considered by ULBs for levying user or service fee for MSWM services.

- **“Polluter pays” principle:** Those responsible for waste generation should pay for its collection and safe disposal.
- **Proportionality:** The user fees should be in proportion to the quantity of waste generated and level of service provided to waste generators. Households generate much less waste as compared with commercial, institutional, and industrial establishments; and among the households, the poor generate less waste as

<sup>18</sup> “Economic Instruments in the Waste Management Sector”, GIZ (2010). Available at: <http://www.giz.de/de/downloads/gtz2010-en-foes-economic-instruments-waste-management.pdf>

compared with the rich households. Therefore, variable rate may be prescribed for different categories of waste generators keeping in mind their waste generation potential. At least three categories of service charge may be prescribed for:

- i. households;
  - ii. commercial, institutional, industrial waste generators; and
  - iii. bulk waste generator such as hotels, function halls, restaurants, and large commercial, institutional, and industrial establishment, etc.
- **Capacity to pay:** Affordability of the taxpayer may be kept in mind while fixing user charges. A fair service charge tariff will facilitate better compliance. Moderate rate, least exemptions, and wider coverage of all classes of taxpayers will fetch higher revenues.

The following criteria may be considered for enhancing the tax base in an ULB:

- **Subsidy for the poor:** The element of cross-subsidisation may be introduced to give relief to the poor and disadvantaged to ensure that they are not deprived of basic services.
- **Higher rates from nonresidential establishments:** Higher rates may be prescribed for commercial, institutional, and industrial establishments and bulk waste generators as they produce substantially more waste than households and usually have a better capacity to pay.
- **Willingness to pay:** People are usually willing to pay for a good service. However, it is desirable to ascertain their willingness to pay for different levels of services. Citizens may prefer a higher level of service and be willing to pay more for the same. This consultation will promote better compliance.
- **Introducing higher service fees:** From an assessment of the current scenario of MSWM service fees levied on ULBs, it does not seem practical to immediately introduce higher rates of service fees that may be required to make MSWM services self-sustaining. User fees may be increased gradually, synchronous with the provision of MSWM services. Efforts should be made to reach the level of full sustainability in 5 years. The service fee structure may be so devised that it is commensurate with the level of service provided and may be increased gradually with improved level of services, increasing the level of acceptability among citizens and ensuring their compliance. As an immediate action, SWM service fees may be increased by ULBs to cover the O&M cost in 3 years. Within the same ULB, where the level of service differs in different wards or areas, differential rates may be charged in



Efficient administration of service fee depends on 3A's:

- Accountability
- Acceptability
- Affordability

different areas in accordance with the level of service. Uniform rates may be applied to currently underserved areas, when full coverage is provided to these areas. However, services to the poor may continue to be subsidised, even when full service levels are achieved in such areas.



### Measures to Minimise the Burden of Service Charges Making Solid Waste Management Effective and Affordable

1. Street sweeping and its disposal should be charged to general taxes. Costs for provision of basic municipal solid waste management services such as general street cleaning, drainage cleaning, cleaning of public spaces, etc. can be met through general taxes which are typically used to finance public services.
2. Municipal authority should introduce 100% door-to-door collection. Door-to-door collection, transportation, processing, and disposal of waste may be completely entrusted to the private sector to ensure efficiency and to economize expenditure of the urban local body (ULB). User fees may be levied to cover full operation and maintenance (O&M) cost of collection and transportation and part of the cost of treatment and disposal of waste. Processing facilities may be created on a public-private partnership (PPP) basis to keep costs under control. Smaller municipalities should go in for simple contracts which can be financed and managed by the ULB.

### Steps for Determining Service Fee

Determining MSWM fee involves several considerations such as (i) capital and O&M cost of services, (ii) number and type of waste generators, (iii) level of service to be provided, (iv) willingness and ability to pay for the service, (v) levels of targeted subsidy, (vi) required establishment cost of the institutional arrangement for service delivery and cost recovery, etc. Evidence of the rationale used for defining MSWM fees could be a key factor in securing political commitment to regulate and enforce user fee collection.

The following steps may be taken by ULBs to determine service fee structure:

1. Understand tariff or fee base.
2. Set norms of tariff fixation.
3. Communicate with consumers.
4. Set method of collection of SWM service fees.

**Step 1: Understand tariff or fee base:** The first step of tariff setting is to understand the target for base of MSWM tariffs. ULBs need to understand the number and type of waste generators to estimate volumes and types of waste generated and MSWM expenditure. ULBs also need to identify service options. These considerations will form the basis for determining the tariff rate.

While determining SWM service fee, the capital, O&M, institutional, political and social arrangements should be considered



The following analysis is required to estimate levels and costs of service provision which are required for determining tariffs for different levels of customers:

**a) Classifications of waste generators**

Classify waste generators into different categories such as households, commercial, and institutional establishments and determine their numbers. This will help the ULBs in understanding the number and type of waste generators to be served and the frequency of service required. The following information may therefore be gathered from each of the waste generator groups:

- Household consumers
  - Current number of households in each settlement area such as ward
  - Status of collection service in different types of settlements such as door-to-door collection, community bin collection, or none
  - Frequency of collection
  - Level of service desired by the households; and willingness of the households to practice the 3R approach (reduce, reuse, recycle), to segregate the waste at source, to do home composting, etc.
  - Willingness to pay and ability to pay
- Commercial and institutional establishments
  - Number of shops and establishments
  - Number of institutions (offices, schools and colleges, temples)
  - Hospitals, hotels, restaurants, guesthouses, etc.
  - Number of industries (manufacturing industries)
  - Status of collection service such as door-to-door collection, community bin collection, or none
  - Frequency of collection
  - Level of service desired
  - Willingness to practise 3Rs and segregate the waste at source
  - Willingness to pay and ability to pay

The data may be analysed and classified into different groups such as: (i) poor and non-poor households; (ii) small and medium shops and establishments (less than 200, 500, 1000 ft<sup>2</sup> in area); (iii) large commercial establishments (more than 1,000 ft<sup>2</sup>); and (iv) bulk waste generators.

## b) Estimates of waste generation:

It is essential to have a fair estimate of the amount of waste generated in the city or town that will help in estimating the staffing and the vehicles and equipment required for primary collection, transportation, treatment, and disposal of waste.

- **Households:** ULBs should collect data on domestic waste generated per capita per day by different households in the city and its composition (organic and inorganic waste). Generally, higher income households generate more non-biodegradable and recyclable waste such as packaging materials, glass, metal, etc.
- **Non-residential premises:** ULBs should collect data on waste generated by shops, offices, workshops, hotels, marriage halls, malls, restaurants, etc.; and on non-hazardous health care and industrial waste generated daily in the city.
- **Bulk waste generators:** ULBs should collect data on estimated waste from public places, parks and gardens, large hotels, commercial establishments, non-residential complexes, vegetable and fruit markets, meat and fish markets, daily street cleaning and drain cleaning activities, and unauthorised disposal sites in the city.

The data will help in scientifically determining the variable rates for different categories as mentioned above. It will also give an indication of the actual cost incurred by the ULB in providing services. The scientific method for estimating waste generation rates in a city is given in section 1.4.3.3.1 of this chapter.

## c) Cost estimates

An analysis of costs for various levels of service provision is necessary to determine the fee structure. Cost components for MSWM services are the following:

- Collection
  - Types of collection vehicles and technology used
  - Staffing required for providing collection service
  - Capital cost of storage bins, collection vehicles
  - Cost of fuel, labour, materials, safety measures, maintenance, personal protective equipment (PPE), depreciation
  - Cost per tonne of waste collected per day
  - Overhead costs

- Transportation
  - Transportation cost from door-to-door collection site to the treatment or disposal site; or from community bins, transfer stations, or material recovery facility (MRF) to treatment or disposal site
  - Cost of transportation vehicles and equipment required
  - Cost of transfer station
  - Cost of fuel, labour, maintenance, safety measures, PPE, depreciation
  - Cost per tonne of waste transported
  - Overhead costs
- Processing
  - Type of processing technology adopted
  - Cost of construction of processing facility
  - Cost of O&M of the processing facility
  - Residual financial burden on the ULBs, including tipping fee (if PPP mode is adopted)
  - Cost per tonne of waste treated
  - Overhead costs
- Disposal
  - Land cost or lease cost
  - Sanitary landfill construction cost
  - Vehicles and equipment cost
  - Environmental protection costs in affected areas
  - Sanitary landfill O&M cost
  - Labour, fuel, amenities cost
  - Closure, monitoring & rehabilitation costs, capital and recurring cost of per tonne waste disposal
  - Overhead costs
- Administrative overheads
  - Daily office or staff expenditure
  - Billing and revenue collection charges
  - Public awareness
  - Information system and data collection or management information system (MIS)
  - Overhead costs

#### d) Service options

Service levels selected to cater to user's requirements, e.g., types of tools, equipment, and vehicles to be used; frequency of service to be provided; etc. will determine the cost of service. ULBs need to decide on the level of service it desires to provide keeping in mind the cost of services and its capability to recover the cost. Service levels need to be determined prior to fixing service fee. The followings are the options for the ULB:

- Consumers
  - Residential consumers in urban areas: Door-to-door collection of MSW from households on a daily basis may be considered necessary.
  - Non-residential consumers:
    - a. Door-to-door collection from commercial establishments and offices or curbside collection on a daily basis may be considered as an adequate service level.
    - b. For bulk waste generators such as hotels, restaurant, and large complexes, waste collection service can be given on a demand basis. The service levels may be determined contractually keeping in mind the amount and type of waste generated.
    - c. For vegetable and fruit market waste and construction waste generating sites, the ULB should provide waste storage containers and transport them on a regular basis as per contractual terms.
- Public Places
  - ULB is required to clean all public places and roads in residential and commercial areas, including street sweeping and cleaning of surface drains.
  - Special cleaning services could be provided on chargeable basis during or after special events in public places.

#### Step: 2 Norms of fee fixation

Key considerations for prescribing a fee structure for provision of MSWM services:

- Surveys have indicated that urban poor generate about 100 g/capita, whereas the rest generate above 200 g/capita/day. This justifies the variable charges for the different strata of society. Because they generate less quantity of waste and have lower capacity to pay, urban poor may be charged 50% lower fees than other income groups on the basis of equity.



### Criteria for Giving Subsidy to Urban Poor

Identification of urban poor is essential to enable access to urban services at a subsidized rate. The following process may be followed by the ULBs for identifying poor and vulnerable sections of the community to administer lower MSWM charges:

The economic status of families may be determined based on the type and size of dwelling units or localities and level of basic service provided to them. As a rule of thumb, people living in slums and informal settlements, devoid of basic services, may be considered to be eligible to pay lower rates of service fee. Besides slum dwellers, residents in dwelling units smaller than 25 m<sup>2</sup> could also be given the benefit.

- The commercial, institutional, and industrial establishments generate larger quantities of waste. The rate could be kept higher for large commercial establishments and bulk waste generators, considering the large quantity and volume of waste generated by them.
- A minimum of 50% of door-to-door collection costs (including O&M costs) should be recovered from households initially and 100% in case of non-residential premises.
- ULBs may charge higher rates in areas with higher levels of service and should aim at achieving 100% cost recovery within 3 years. In case of institutional, commercial, and industrial buildings, 100% O&M cost recovery may be made from the very beginning.



### Rationale for Determining Tariff for Door-to-door Collection Service

- 100% O&M cost recovery: institutional, commercial, and industrial waste
- 50% O&M cost in beginning and 100% in 3 years: general households
- 25% O&M cost in beginning and 50% in 3 years: poor households

#### Norms for Tariff Determination for Door-to-door Collection

- Tariff for nonresidential premises based on the size of the premises:
  - Up to 1,000 ft<sup>2</sup> (small tenements): Rs A
  - 1,001–2,000 ft<sup>2</sup> : Rs A x 2
  - 2,001–4,000 ft<sup>2</sup> : Rs A x 3
  - More than 4,000 ft<sup>2</sup> : Rs A x 4
- Bulk waste generators and vegetable, fruit, meat, fish markets: Fees fixed on the basis of volume and quantity of waste generated per day; fees should recover 100% of the O&M cost and should consider number of units served (in case of markets)
- No fee may be collected for cleaning and collecting waste from public places. Revenue from the general tax may be used to cover these costs.

### **Step 3: Communication with consumers**

To gain popular acceptance of MSWM service fee by the users, it is important that the process of determining the fee is transparent and communicated to all stakeholders. ULBs may organise public consultation to have citizens' views on the proposed service fee structure and levy of lower rates on the poor. This will facilitate better acceptance and payment of user fees.

### **Step 4: Mechanisms for recovery of municipal solid waste management user charges**

Presently, the use of economic instruments for recovery of SWM costs in India is not well established, although some instruments are used to a limited extent. However, the use of environmental fiscal reform through appropriate economic instruments for financing MSWM can fill some of the gaps that have been identified by the ULBs. Some of the possible methods for recovering MSWM charges are tabulated below in Table 1.12.

**Table 1.12: Mechanisms for Recovery of Municipal Solid Waste Management User Charges<sup>19</sup>**

| MECHANISM   | ADMINISTRATIVE COSTS: TAX AND DATA COLLECTION, MONITORING, IDENTIFICATION OF USER CHARGES   | SOCIAL EFFECTS: VERTICAL AND HORIZONTAL EQUITY; LINKAGES WITH ABILITY TO PAY  | ENVIRONMENTAL EFFECTS: LINKAGES TO WASTE GENERATION AND INCENTIVE TO REDUCE WASTE   | REVENUE GENERATION AND POTENTIAL COST RECOVERY  | POLITICAL AND PUBLIC ACCEPTANCE   |
|---|---|---|---|---|---|
| <ul style="list-style-type: none"> <li>Levy of SWM tax along with property taxes, determined on the basis of the unit area base system (ABS) (household or commercial establishments).</li> </ul> | <ul style="list-style-type: none"> <li>Shift to ABS will result in simple and transparent tax administration system.</li> <li>making monitoring easier.</li> <li>This will result in clear identification of small and large waste generators and their categories.</li> <li>This will facilitate collection of SWM charges along with annual property tax, thereby minimising cost of tax recovery.</li> </ul> | <ul style="list-style-type: none"> <li>Cross subsidisation can reduce the tax burden of poorer households.</li> <li>This can be horizontally equitable if amount paid is linked to the service levels and the quantity of waste generated.</li> </ul> | <ul style="list-style-type: none"> <li>Generation based solid waste tax would lead to bulk waste generators paying higher charges than smaller generators.</li> </ul> | <ul style="list-style-type: none"> <li>Solid waste tax can only be revised along with property tax, which is revised 5 yearly.</li> <li>This will depend on the existing collection efficiency of property tax which is very low, but is expected to increase with the shift to unit ABS of property taxation.</li> </ul> | <ul style="list-style-type: none"> <li>Unit ABS is already accepted and currently in place in many states.</li> <li>Any increase in SWM tax rates will need to be justified and will require political support for implementation.</li> </ul> |

<sup>19</sup> "Environmental Fiscal Reforms in India: Where and How?", GIZ and TERI (2011).

**Table 1.12: Mechanisms for Recovery of Municipal Solid Waste Management User Charges [contd.]**

| MECHANISM  | ADMINISTRATIVE COSTS: TAX AND DATA COLLECTION , MONITORING , IDENTIFICATION OF USER CHARGES  | SOCIAL EFFECTS: VERTICAL AND HORIZONTAL EQUITY; LINKAGES WITH ABILITY TO PAY   | ENVIRONMENTAL EFFECTS: LINKAGES TO WASTE GENERATION AND INCENTIVE TO REDUCE WASTE  | REVENUE GENERATION AND POTENTIAL COST RECOVERY   | POLITICAL AND PUBLIC ACCEPTANCE   |
|--|--|--|--|--|---|
| <ul style="list-style-type: none"> <li>Levy of separate solid waste user charges and using direct collection or “pay as you throw systems”.</li> </ul> | <ul style="list-style-type: none"> <li>This will add to the cost of tax administration as a separate arrangement and will have to be made for collection of user fee. If the responsibility of collection of user fees is passed on to the PPP partner, the municipal administration cost may reduce but actual cost may not as collection cost may be added by the contractors in their tipping fees. Besides, the concessionaires, not having legal powers may not be in a position to collect from defaulters and this will necessitate enforcement measures by the local authorities to recover dues from defaulters.</li> <li>“Pay-per-bag” systems may provide incentives to minimise waste generation or littering. This system can be implemented with adequate checks and balances.</li> <li>Measuring waste may be a problem.</li> </ul> | <ul style="list-style-type: none"> <li>This can be vertically and horizontally equitable if amount paid is linked to the unit area based service levels and the quantity of waste generated.</li> <li>This can be vertically equitable if charges levied vary with socioeconomic status: reduced rates for poor households and higher rates for rest.</li> </ul> | <ul style="list-style-type: none"> <li>This provides incentives for waste reduction and supports the proportionality principle (the more you generate, the more you pay).</li> </ul> | <ul style="list-style-type: none"> <li>Collection efficiency will be important in determining the cost recovery.</li> <li>Administrative costs for direct collection need to be determined.</li> <li>Flat rate charges and variable rate charges generate less variability in revenue.</li> <li>If based on service level or on quantity of waste delivered, this may encourage illegal dumping, since people may not want to pay higher charges.</li> </ul> | <ul style="list-style-type: none"> <li>This needs political support in introducing user fees in addition to property tax. The user fee structure needs to be designed scientifically, and increasing the charges from year to year could be difficult.</li> </ul> |





**Table 1.12: Mechanisms for Recovery of Municipal Solid Waste Management User Charges [contd.]**

| MECHANISM   | ADMINISTRATIVE COSTS: TAX AND DATA COLLECTION , MONITORING , IDENTIFICATION OF USER CHARGES   | SOCIAL EFFECTS: VERTICAL AND HORIZONTAL EQUITY; LINKAGES WITH ABILITY TO PAY                     | ENVIRONMENTAL EFFECTS: LINKAGES TO WASTE GENERATION AND INCENTIVE TO REDUCE WASTE  | REVENUE GENERATION AND POTENTIAL COST RECOVERY   | POLITICAL AND PUBLIC ACCEPTANCE  |
|---|---|--|--|--|--|
| <ul style="list-style-type: none"> <li>Levy of user charge linked to utility (water and electricity) bill.</li> </ul> | <ul style="list-style-type: none"> <li>This can be an efficient and cost-effective system in recovery of user charges, as defaulters will have a fear of disconnection of utility service in case of failure to pay. Administration cost will also go down substantially as user fees will get collected monthly or bimonthly along with utility charges. This will also result in maintaining a cash flow to ensure timely payment to the service provider.</li> <li>Willingness of concessionaire is necessary to undertake this responsibility on payment of a small fee; administration cost of ULB will thus be very low.</li> <li>Some cost may be incurred in the transfer of funds from the ULB to the concessionaire.</li> </ul> | <ul style="list-style-type: none"> <li>Will be horizontally and vertically equitable.</li> </ul> | <ul style="list-style-type: none"> <li>Provides no incentives for waste reduction but does have inbuilt equity.</li> </ul> | <ul style="list-style-type: none"> <li>Collection efficiency of user fees will increase substantially and help ULBs in paying the concessionaire on time and make PPP service sustainable .</li> </ul> | <ul style="list-style-type: none"> <li>Linking of the MSWM charge to the already existing utility billing system will require negotiations with utility company.</li> <li>Political and public acceptance may be a problem.</li> </ul> |

### (c) Municipal resources that include taxes and duties

Traditionally, property tax in India has been the main source of revenue for ULBs to finance municipal services including MSWM. Rationalisation of the property tax is required to ensure financial sustainability of these services.

### (d) Grants from central or state government

It has been widely recognised that ULBs are unable to meet the expenditure for their activities solely by internal resources. Hence, ULBs require substantial financial support from the central and state government in the form of grants and funds. Some of the grants and funds available to ULBs are:

- finance commission grants;
- central government grants (e.g., JnNURM, Swachh Bharat Abhiyan); and
- state finance commission grants allocated by the state to local authorities once every 5 years to support administrative, governance, and municipal service delivery.

### (e) Subsidies:

The Ministry of New and Renewable Energy (MNRE) has been promoting waste to energy projects—refuse derived fuel (RDF), biomethanation, biogas, and gasification—by providing financial incentives to proponents. The incentives are given to both private and public sector entrepreneurs and investors. The subsidy has been Rs15 million–Rs30 million per MW. For commercial projects, financial assistance is provided by way of interest subsidy to reduce the rate of interest to 7.5% capitalised with an annual discount rate of 12%. The assistance or subsidy is routed through financial institutions.

- Financial assistance up to 50% of capital cost of the project limited to Rs 3.00 crore per MW is provided to the project proponent for demonstration projects.
- In addition to the above, financial incentive at Rs. 15.00 lakh per MW is given to municipal corporations or ULBs for supplying the garbage free of cost at the project site and providing land on a long term lease (30 years and above) at a nominal rent.
- State nodal agencies are given an incentive at Rs. 5.00 lakh per MW of power for promotion, coordination, and monitoring of projects.

- There is also a provision for financing 50% of the preparation cost of detailed project reports (DPRs) or techno-economic feasibility reports, subject to a maximum of Rs. 2.00 lakh per report to the project proponent.

The Ministry of Environment and Forests and Climate Change (MoEFCC) and the Ministry of Agriculture (MoA) have subsidised compost plants up to 50% of the capital cost. The purpose of the subsidies has been to promote technologies which might otherwise not be taken up on purely financial grounds.

**(f) Loans from capital market or from government or financial institutions**

ULBs can also approach capital markets either directly or through an intermediary. The ULBs can also take advantage of funding for SWM from financial institutions which charge relatively lower rates of interest. Some of the financial institutions include the following:

- Housing and Urban Development Corporation (HUDCO)
- Infrastructure Development Finance Company (IDFC)
- Infrastructure Leasing and Financial Services (IL&FS)
- National Bank for Agriculture and Rural Development (NABARD)
- Indian Renewable Energy Development Agency (IREDA)
- Industrial Development Bank of India (IDBI)
- Industrial Finance Corporation of India (IFCI)
- Commercial banks, suppliers, creditors, and private venture capital funds

**(g) Loans and grants from bilateral and multilateral Donors**

ULBs could also consider the opportunity of funds from bilateral and multilateral donors like ADB, KfW, the World Bank, etc. for soft loans and grants for infrastructure projects, after due approval from the State. States could also access these funds and provide them to the ULBs.

**(h) Public private partnerships**

Private sector joining hands with the public sector has become essential for providing MSWM services and creating infrastructure for collection, transportation, treatment, and disposal of waste, resulting in efficient maintenance and cost-effective provision of services.

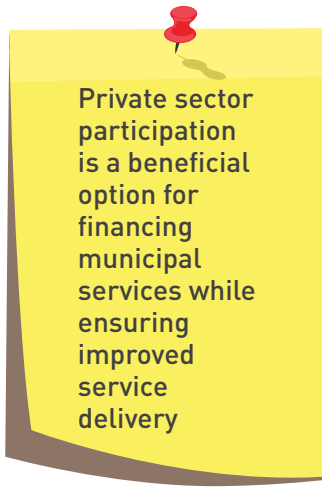

Private sector participation is a beneficial option for financing municipal services while ensuring improved service delivery

The success of PPPs depends on the three necessary conditions of competition, transparency, and accountability

Private sector participation (PSP) brings in efficient technology, financial resources, trained staff, managerial autonomy, and efficiency in operation at a relatively low cost along with accountability and flexibility in bringing about a change as and when required.

Public private partnership has distinct advantages and challenges which must be taken into consideration while embarking on the PPP mode of service delivery. The advantages include flexibility, increased efficiency, and contestability:

#### **Flexibility:**

- the private sector can easily hire qualified staff members and pay the salaries as per expertise.
- salaries and bonuses can be linked to staff performance, thereby providing incentives for efficiency and good work.
- employee can be easily terminated when performance is unsatisfactory.
- administration is more effective due to fewer bureaucratic responsibilities.
- there is less political interference with private sector involvement.
- decision-making process is faster and simpler.

#### **Increased efficiency:**

- new equipment or spare parts for equipment maintenance can be easily acquired.
- the private sector is more open to technology and expertise.
- the private sector has easy access to financial resources for new investments.
- full cost accounting is used.
- incentives for good performance and efficiency are offered.

#### **Contestability:**

Competition between the private and public sectors is effective in improving cost-effectiveness.

Some of the challenges for effective PPP implementation include:

- performance monitoring,
- customer satisfaction, and
- accountability to the beneficiaries for services rendered.

Regular monitoring and reviewing of performance of the private entity against predefined performance criteria by the ULBs is important for the success of PPP projects.

The ULB should ensure that the private sector player is selected through a transparent selection process after carefully prescribing minimum qualification and experience needed to perform the function effectively and the contract documents are prepared professionally. The ULB also has an obligation to ensure that the private sector partner adheres to the local, regional, and national legal requirements which entail workers' rights, workers' equitable remuneration, and other legal requirements or factors such as bonuses, maternal or paternal leave, annual leaves, clauses for termination with proper notice periods, setting up of staff committees, sexual harassment committees (now mandated by law), and other labour rights based units.

Management of PPPs is another critical issue, which will ultimately determine the success of the project. A well-defined action plan, including a plan to monitor specific indicators is essential to evaluate the performance of any project. The ULB should have appropriate inhouse capacity to regularly review the performance of all PSP or PPP projects. Further details on contract monitoring are included in section 5.4.7 of Part II.

#### (i) **Municipal bonds and debentures**

This is a good source of raising finance from the market and very popular in several developed countries. Tax-free municipal bonds can be issued for raising finances from the market for infrastructure development. Such bonds can be issued by ULBs having good financial health and good credit rating to attract investors to invest in municipal bonds. The amount invested is redeemable after a specific period with a definite rate of interest. Presently, the concept of municipal bonds is at a nascent stage in India and only a few ULBs with a large and buoyant revenue base (credit rating) have been successful in raising funds through them (e.g., Ahmedabad has raised funds several times through tax-free bonds and have been able to raise money for infrastructure development very swiftly).



Ahmedabad Municipal Corporation is one of the pioneering cities to issue municipal bonds and debentures

#### (j) **Revenue from sale of products derived from waste processing**

ULBs can minimise expenditure by seeking PSP. For waste processing, private sector entities can be entrusted with the responsibility of processing the municipal waste at their own cost, by allowing them to set up the waste processing facilities on municipal land and giving them the agreed quantity of waste at designated site for a fixed contract period. ULBs may set up such facilities at their own cost and carry out its O&M through expert agencies and earn revenues from the sale of end products like compost, RDF, or electricity.

### (k) Tipping fee, solid waste tax

This could be another source of revenue. The fee may be prescribed for large waste generators for processing and disposal of their waste at the landfill. This could be in the form of fixed monthly fee for providing access to the processing and disposal facility.

#### 1.4.5.6.4 Deficit Management

The ULB should endeavour to recover 100% of the total costs of services as estimated above through levy of user charges on “polluter pays” principle. This should include costs of door-to-door collection, transportation, processing, and final disposal of waste at the landfill. The cost of street sweeping, its transportation, and disposal should be met from the municipal general budget. Since it may not be immediately achievable to recover the costs of service indicated above through user fees, however it is important to initiate the process of recovering at least 100% of the cost of collection and transportation (O&M costs only) through levy of user fees within 3 years; subsequently the user fees may be gradually raised to cover the gap in recovery of processing cost and O&M costs. Table 1.13 indicates a format for recording the revenue required to bridge the financial viability of providing MSWM services.

**Table 1.13: Format for Assessing the Gap and Bridging the Financial Deficit for Municipal Solid Waste Management Services**

| S. NO | DESCRIPTION                    | YEAR<br>01 | YEAR<br>02 | YEAR<br>03 | YEAR<br>..... | YEAR<br>20 |
|-------|--------------------------------|------------|------------|------------|---------------|------------|
| 1     | Deficit                        |            |            |            |               |            |
| 2     | Target % to be met by user fee |            |            |            |               |            |
| 3     | Municipal fund                 |            |            |            |               |            |
| 4     | State subsidy or other sources |            |            |            |               |            |

Mechanisms for collecting user fees need to be put in place, and the user fee collection system should be institutionalised. If necessary, the Municipal Act 1872, needs to be suitably amended to enable these actions. A detailed cost recovery report should be prepared covering the whole gamut of MSWM. The ULB should allocate only the required resources as planned and attempt to work within the earmarked and identified resources. Any excess staffing or vehicles available or deployed should be phased out, resulting in a reduction of actual costs.

### 1.4.5.7 ANALYSIS OF APPROPRIATE PUBLIC PRIVATE PARTNERSHIP CONTRACT MODELS

ULBs should first assess whether they are able to provide MSWM services on their own or will need to outsource due to considerations of limited capacity, staffing, and other resources. In the latter case, the services to be outsourced should be deliberated upon and defined in sufficient detail and should fit into the larger MSWM plan for the ULB. ULBs may contract private service providers for specified solid waste collection, transportation, treatment, processing, and disposal services.

A contract between a public and private entity is an arrangement between two parties where the private party is paid a fee for investing in necessary infrastructure, vehicles, and equipment or for managing an existing asset or business as well as providing the desired services. Management contracts transfer limited responsibilities and risk to the private party, whereas contracts like design–build–own–operate–transfer (DBOOT) put significant responsibility on the contractor. The contracts have to be structured in a way that they bridge the financial and institutional gap which ULBs cannot fill easily from internal resources and capabilities.

Contracting models should be performance-based and the payments made to private partners should be linked to outputs reflecting the service quality levels which are predefined in the contract.<sup>20</sup>

ULBs should play a critical role in monitoring various contractual arrangements to avoid risks associated with contracts

**Table 1.14: Key Characteristics of Contracts in Municipal Solid Waste Sector<sup>21</sup>**

| MSW MANAGEMENT & OPERATION    | CHARACTERISTICS  | RELEVANT CONTRACT MODELS  | IMPLEMENTING ULB                                  |
|-------------------------------|--|---|---|
| Collection and Transportation | <ul style="list-style-type: none"> <li>Large and diverse workforce, vehicles and equipment</li> <li>Intensive logistics</li> <li>Citizen interface</li> <li>Investment ranges widely depending on scope of work</li> </ul> | Service contracts;<br>Management contracts;<br>Concession contracts | Bangalore, Surat, Chennai, Ahmedabad, etc.        |
| Street sweeping               | <ul style="list-style-type: none"> <li>Labour intensive</li> <li>Minimal investment in tool and equipment</li> <li>Limited technical skills</li> <li>Logistics intensive</li> </ul>  | Service contracts   | Delhi, Hyderabad, Chennai, Rajkot, Surat etc.     |
| Transport                     | <ul style="list-style-type: none"> <li>Capital intensive</li> <li>Fleet management skills</li> </ul>   | Concession contracts  | Bangalore, Delhi, Chennai, Surat, Ahmedabad, etc. |

<sup>20</sup> Draft National Public Private Partnership Policy, Government of India (2011).

<sup>21</sup> Subject to compliance with Contract Labour Regulation Act (CLRA) (1996).

**Table 1.14: Key Characteristics of Contracts in Municipal Solid Waste Sector [contd.]**

| <b>MSW MANAGEMENT &amp; OPERATION</b> | <b>CHARACTERISTICS</b>  | <b>RELEVANT CONTRACT MODELS</b>  | <b>IMPLEMENTING ULB</b>                         |
|---------------------------------------|---|--|---|
| Processing / disposal                 | <ul style="list-style-type: none"> <li>• Capital intensive</li> <li>• Technically skilled staffing required</li> <li>• Experience of technology deployed</li> </ul> | Concession contracts (Design Build Operate [DBO], Build Own Operate (BOO), Design Build Own Operate Transfer (DBOOT) | Surat, Pune, Delhi, Hyderabad, Coimbatore, etc. |

Table 1.14 summarises relevant contracts for specific MSWM activities. While each of the operations have a distinct scope and can be handled under separate contracts, various models exist for efficient MSWM, which revolve around a combination of these operations. Some of the possible combinations of contracts include:

1. separate contracts for collection, transportation, processing, and disposal activity (four contracts);
2. collection and transportation contract, processing contract, and disposal contract (three contracts, as in Shimla);
3. collection and transportation contracts in one package and processing and disposal contracts in another package (two contracts, as in Bengaluru); and
4. one integrated contract for all four activities (as in Raipur, Guwahati, Jodhpur, Lucknow, Kanpur, Allahabad, etc.).

Each of the above options has certain advantages and disadvantages and may be adopted with checks and balances in the contracts to minimise the risks. In each successive model, the level of responsibility on the private player is relatively higher, with the fourth model allocating the highest responsibility to the private entity. The ULB plays the role of a client and a monitoring agency. Through this model, a high degree of accountability and better compliance is achieved, as the private agency is a professional player liable to the ULB.

The Government of India in cooperation with ADB elaborated a “Toolkit for Public Private Partnership frameworks in Municipal Solid Waste Management”<sup>22</sup> which supports ULBs within a four-step approach to establish a PPP system adequate to the conditions in the respective city. It is strongly recommended to apply this toolkit for establishing a ‘hand-tailored’ PPP system.

<sup>22</sup> Toolkit for Public Private Partnership frameworks in Municipal Solid Waste Management Volume I-III. Ministry of Urban Development (MoUD).



**Table 1.15: Contracting Models and Private Sector Responsibilities<sup>23</sup>**

| OPTION                     | GENERAL CHARACTERISTICS  | AIM OF HAVING PRIVATE SECTOR PARTICIPATION   | OPERATIONS AND MAINTENANCE | CAPITAL INVESTMENT AND ASSET OWNERSHIP | RESPONSIBILITY | CONTRACT DURATION      |
|----------------------------|--|--|----------------------------|--|----------------|------------------------|
| Service Contract           | The private sector provides a clearly defined service to the public partner.   | Increase efficiency of particular public service   | Shared                     | Public                                 | Public         | 1-2 years or 5-8 years |
| Management Contract        | The private partner is responsible for operating and maintaining the system.   | Increase efficiency of service, with improved management structures  | Private                    | Public                                 | Public         | 3-5 years              |
| Design-Built-Operate (DBO) | The private contractor is responsible for designing, constructing, and infrastructure developments.  | Enhance commitment level because of full responsibility  | Private                    | Public                                 | Shared         | 5-8 years              |
| Lease                      | The private partner is fully responsible for operation and maintenance.  | Increased responsibility   | Shared                     | Public                                 | Public         | 8-15 years             |
| Build-Own-Operate (BOO)    | The private partner builds a facility that is based on a defined design and owns and operates it. The private partner charges a tipping fee to recover its cost. | To transfer the responsibility of investment and management in a cost-effective manner with all risks on the private partner | Private                    | Private                                | Private        | 15-30 years            |

<sup>23</sup> Adapted from Cointreau-Levine (1994); International Consortium, GTZ-ERM-GKW (2004); World Bank (2004)

**Table 1.15: Contracting Models and Private Sector Responsibilities [contd.]**

| <b>OPTION</b>                         | <b>GENERAL CHARACTERISTICS</b>   | <b>AIM OF HAVING PRIVATE SECTOR PARTICIPATION</b>  | <b>OPERATIONS AND MAINTENANCE</b> | <b>CAPITAL INVESTMENT AND ASSET OWNERSHIP</b> | <b>RESPONSIBILITY</b> | <b>CONTRACT DURATION</b> |
|---------------------------------------|--|--|-----------------------------------|---|-----------------------|--------------------------|
| Build–Own–Operate–Transfer (BOOT)     | The private partner builds a facility that is based on a defined design and owns and operates it. The private partner charges a tipping fee to recover its cost. The private company then transfers asset to the public partner. | Obtain private sector investment with operating and management risks on the private partner and eventual asset transfer to the public. | Private                           | Private                                       | Private               | 15-30 years              |
| Build–Operate–Transfer (BOT)          | The private partner is responsible for constructing, financing and operating the facility during the contract period. After the contract period, the facility is transferred to the public.                                      | To transfer all risks to the private partner   | Private                           | Private                                       | Private               | 20-30 years              |
| Concession (including fee collection) | The private partner is fully responsible for operation, maintenance and investment.  | To create competition in the market  | Private                           | Private                                       | Private               | 25-30 years              |

### 1.4.5.8 PLANNING FOR CENTRALISED AND DECENTRALISED FACILITIES

Conventionally, MSWM systems were planned for and implemented at the city level, with centralised systems catering to the entire ULB.

Resource, technology, and capital-intensive MSWM services are best planned and executed at the city level; centralised systems are preferred for waste processing and treatment plants like RDF plants and municipal sanitary landfills, which can benefit from economies of scale and for easy management and environmental monitoring.

Decentralised waste management systems or community level waste management systems reduce the burden of handling large volumes of MSW at a centralised location, with a corresponding reduction in costs of transportation and intermediate storage. Especially for decentralised facilities, their success depends on segregated doorstep collection. All decentralised schemes should be assessed for long term sustainability and their impact on the overall MSWM system of a city should be identified and considered while planning for citywide waste management facilities.

Interactive planning along with the community is required to decide the extent of centralised and decentralised MSWM systems for continued efficiency.

Advantages of centralised systems include (i) economies of scale, (ii) single monitoring point, (iii) high-end technology, and (iv) environmental controls.

Limitations of centralised systems include (i) larger tract of land, (ii) fund limitations, (iii) experience of ULBs in managing large contracts, (iv) high potential for environmental failure of systems where environmental controls are not in place or monitored.

#### 1.4.5.8.1 Role of Decentralised Municipal Solid Waste Management Systems

Decentralised waste management systems or community level waste management systems reduce the burden of handling large volumes of MSW at a centralised location, with a corresponding reduction in costs of transportation and intermediate storage.

Decentralised MSWM solutions are suitable in the following scenarios:

- Suitable land for waste management facilities (composting organic waste, recyclable sorting facilities) is available in neighbourhoods;



Decentralised systems require a higher degree of commitment from the community, as their participation is crucial in ensuring the sustained performance of these systems

- There is no local resistance against siting the plant;
- Local expertise or non-government organisations (NGOs) handhold the process in an environmentally acceptable manner;
- Municipality has in-house capacity of effectively monitoring decentralised systems;
- Markets for compost and recyclables are accessible;

Some of the advantages of decentralised MSWM are the following:

- Decentralised systems allow for lower level of mechanisation than the centralised solutions. They provide limited income and job opportunity for informal workers and small entrepreneurs;
- Decentralised options can be tailor made for the local waste stream, climate, social, and economic conditions;
- Decentralised systems reduce the cost incurred for the collection, transportation, and disposal of waste by the ULBs;

However, some of the limitations to the implementation of decentralised waste management systems include:

- scarcity of land in most urban neighborhoods;
- lack of availability of technically qualified staff to ensure scientific and hygienic operations;
- difficulty in ensuring periodic check on product quality; and
- difficulty in ensuring financial viability of decentralised projects, specifically when qualified staffing is required.

While planning for decentralised systems, adequate care should be taken to ensure that these systems are an integral part of the larger MSWM plan of the city. Other centralised waste processing and treatment systems should not consider waste volumes which are already being processed and treated in decentralised facilities.

Local material recovery and recyclable sorting facilities, decentralised compost plants, biomethanation (biogas) plants, vermicomposting, windrow composting, and bin-composting are all easy to establish at the community or institutional level. Sizes can vary from small backyard composting to plants processing 3–20 tonnes per day (TPD) of organic waste. Material take-back and recycling facilities can also be established at the local community level to increase efficiency of collection.



Dry waste collection centres run by various agencies in Bengaluru in coordination with the Bruhat Bengaluru Mahanagara Palike (BBMP) are decentralised bulk sorting and processing facilities. Waste managers perform secondary and tertiary sorting of the waste here before finally selling it to recycling centers. Bulk collection through informal sector results in larger returns and more jobs opportunities.



### **Decentralised Waste Management System for Apartment Complexes- A Public Private initiative in Kochi**

**Year of start:** 2007

**Main players:** Cochin Municipal Corporation (CoC), Confederation of Real Estate Developers' Associations of India (CREDAI)

**Approach:** Kochi witnessed rapid urbanisation in the last decade with various developmental and infrastructural projects, and consequently faced the problems of waste management and its disposal. The garbage crisis of 2007 deteriorated the condition of Kochi, as the city had no dedicated site for waste disposal. In order to address the problem of garbage disposal in residential colonies with focus on health, hygiene, and safety, CoC carried out a joint initiative with Kerala Builders Forum later called CREDAI. To manage solid waste, the following approaches were adopted in highrise apartments to implement an eco-friendly solid waste management system:

- A suitable technology was identified and approved by Clean Kerala Mission, Government of Kerala. In 2007, CoC implemented this decentralised system of waste management in few apartment complexes on a trial basis.
- Strategy was planned and formulated and a dedicated team for implementation of the decentralised system was set up for the-high rise apartments.
- CoC set up source segregated door-to-door collection system of waste in each of the apartment complexes.
- Bio-bin system was established to process biodegradable waste to produce and utilize the compost on-site within the apartment complex.
- A recycling and plastic shredding unit was established by CoC and managed by CREDAI.
- Dry or recyclable material was collected and sold to generate revenue for the CREDAI workers.
- CoC promoted regular skill development and awareness programs for the workers and citizens through print and mass media.

#### **Outcome:**

- Currently, 350 apartment complexes in Kochi are covered under this initiative.
- Decentralised system in apartment complexes led to employment opportunities for economically weaker sections, especially women, for operationalising and monitoring the unit.
- Monitoring was effective and complaint redressal (e.g., during unit failure) was timely.

### Success Factors

- Legal framework making the system mandatory for all apartment complexes
- Proactive role of CoC to decentralize waste management within all apartment complexes and regular monitoring by the officials
- Capacity building of the workers
- Regular monitoring by CREDAI at the premises

### Overall Sustainability

The initiative of CREDAI in the apartment complexes is a self-sustainable working model showcasing the viability of decentralised waste management systems. On-site operation and maintenance of the composting system as well as other expenditures are being met by the collection of user charges at the rate of Rs. 100–150 and by the sale of recyclables. In order to further strengthen and ensure sustainability of the system, Local Self Government Department (Government of Kerala) issued an order in 2012 making it mandatory for all apartments, through the building associations or firms, to manage waste within the apartment complexes using different technologies for composting and for sale of recyclable material.

*Source: CoC.*



Bhabha Atomic Research Centre (BARC) has developed Nisargruna technology for generating biogas from organic waste. Small plants operating 0.5–5.0 tonnes per day (TPD) can be set up at an affordable cost at decentralised locations or large institutions, markets, etc. More than 150 plants are operational in the state of Maharashtra and few other states.

#### 1.4.5.8.2 Management and Monitoring of Decentralised Municipal Solid Waste Facilities

A decentralised facility at the household level need not be registered; however, all other decentralised facilities operating more than 1 TPD of waste should be registered with the local authority. Appropriate norms for operation and maintenance (O&M) should be prescribed for the facility, which should be monitored by both the local authority and the pollution control board.

Decentralised MSWM facilities may be funded through community-based cooperatives, local NGOs, PPP mode or municipal funds. Community ownership of decentralised systems is critical for their success and continued operation. The four management models for decentralised waste management systems are tabulated in Table 1.16. The relevance of different models is dependent on local conditions and cultural backgrounds. All the decentralised models are equally beneficial to the ULB by reducing overall waste management costs.

**Table 1.16: Management Models for Decentralised Waste Management<sup>24</sup>**

| OPTIONS  | PURPOSE  | MAIN ACTORS  | ROLE OF CITY GOVERNMENT OR MUNICIPALITY   | ADVANTAGES   | CONSTRAINTS  |
|--|--|--|---|--|--|
| <b>Model 1: Municipality owned – Municipality operated</b> | <ul style="list-style-type: none"> <li>Reducing cost of transportation, centralised treatment, and disposal of waste in landfills</li> <li>Local employment opportunity</li> </ul>   | <ul style="list-style-type: none"> <li>Municipality</li> </ul>                             | <ul style="list-style-type: none"> <li>Investment provider</li> <li>Implementing and monitoring agency</li> </ul>   | <ul style="list-style-type: none"> <li>Cost saving in transportation, centralised processing, and disposal of waste</li> <li>Profitable use of waste</li> <li>Job opportunities for the unemployed youth</li> <li>Entrepreneurship development</li> </ul>  | <ul style="list-style-type: none"> <li>Lack of suitable land</li> <li>Objection from the neighbourhood</li> <li>Occasional problems of odour</li> <li>Operating inefficiency and lack of marketing potential</li> <li>Lack of coordination between departments regarding the use of the compost products within the ULB</li> </ul> |
| <b>Model 2: Municipality owned – community operated</b>    | <ul style="list-style-type: none"> <li>Community involvement in management of primary waste collection and treatment</li> <li>Capital cost borne by local body</li> <li>Local employment opportunity</li> <li>Entrepreneurship development</li> <li>Nonprofit seeking model</li> </ul> | <ul style="list-style-type: none"> <li>Municipality, local community, NGOs RWAs</li> </ul> | <ul style="list-style-type: none"> <li>Making capital investments</li> <li>Supporting communities in finding or allotting land</li> <li>Collection and disposal of residual waste</li> <li>Monitoring agency</li> </ul> | <ul style="list-style-type: none"> <li>Cost saving in transportation and centralised processing and disposal</li> <li>Profitable use of waste</li> <li>Job opportunities for the unemployed youth</li> <li>Entrepreneurship development</li> <li>Reduction in municipal burden due to community participation.</li> <li>Improvement of MSWM through voluntary participation</li> </ul> | <ul style="list-style-type: none"> <li>Lack of community awareness and interest in decentralised project</li> <li>Lack of informal leader among the community to lead the cause of the project</li> <li>Lack of skilled labour and entrepreneurs</li> </ul>  |

<sup>24</sup> Adapted from: "Decentralised Composting for Cities of Low and Middle Income Countries" pp 33. Waste Concern, (2006), Dhaka, Bangladesh.

Table 1.16: Management Models for Decentralised Waste Management (Contd.)

| OPTIONS  | PURPOSE   | MAIN ACTORS  | ROLE OF CITY GOVERNMENT OR MUNICIPALITY  | ADVANTAGES   | CONSTRAINTS   |
|--|---|--|--|--|---|
| <b>Model 3:<br/>Municipality<br/>owned-<br/>privately<br/>operated</b> | <ul style="list-style-type: none"> <li>• Profit seeking model</li> <li>• Full cost recovery (from collection fees and compost sales)</li> <li>• Cost reduction through lower transportation and disposal costs</li> </ul> | <ul style="list-style-type: none"> <li>• Municipality, Private secto, NGO</li> </ul> | <ul style="list-style-type: none"> <li>• Funding capital expenditure</li> <li>• Identify and allot land for composting,</li> <li>• Contracts out the operation and maintenance</li> <li>• Monitors performance of contractors</li> </ul>   | <ul style="list-style-type: none"> <li>• Reduction of municipal burden of waste management through private sector participation</li> <li>• Know-how and efficient management through private sector</li> <li>• Partnership with private entrepreneurs</li> </ul>   | <ul style="list-style-type: none"> <li>• Lack of community awareness and interest</li> <li>• Need for a reliable and skilled partner with sense of entrepreneurship</li> <li>• Inefficient contract management</li> </ul> |
| <b>Model 4:<br/>Privately<br/>owned-<br/>privately<br/>operated</b>    | <ul style="list-style-type: none"> <li>• Profit seeking enterprise based on compost market conditions (Income is generated through sale of products like compost and through collection of charges)</li> </ul>            | <ul style="list-style-type: none"> <li>• Private sector</li> </ul>                   | <ul style="list-style-type: none"> <li>• Selecting a private operator through a transparent process</li> <li>• Formulation of transparent regulations for PPP</li> <li>• Cooperation in supply of raw waste and disposal of residues</li> <li>• Synchronising centralised and decentralised systems</li> </ul> | <ul style="list-style-type: none"> <li>• Reduction of the municipal burden of waste management through private sector participation</li> <li>• Investment of funds and know-how through private investors</li> <li>• Partnerships with private entrepreneurs</li> <li>• Creation of employment and business opportunities</li> </ul> | <ul style="list-style-type: none"> <li>• Lack of private land</li> <li>• Lack of vital compost markets</li> </ul>   |





## Decentralised Model of Integrated Municipal Solid Waste Management in Saharanpur, Uttar Pradesh

**Year of Start:** 2006

**Location:** Saharanpur, Uttar Pradesh

**Main Players:** Muskan Jyoti Samiti (MJS), Saharanpur Municipal Corporation (SMC), Imperial Tobacco Company of India Limited (ITC).

### Approach:

Saharanpur is one of the growing urban centres of the western region of Uttar Pradesh, with a population of more than seven lakh (0.7 million). The city generates huge amounts of municipal solid waste, but SMC was unable to provide adequate and efficient services. This led to the joint initiative by MJS and ITC to provide an integrated waste management facility comprising of segregation, collection, transportation, processing, and disposal of municipal solid waste. Economic viability, environmental sustainability, and continuity are key features of the initiative. During the course of the intervention, MJS facilitated formation of a labour cooperative society, which is now managing the entire operation. The approaches adopted under this initiative are briefly discussed below:

- A well-defined system that reduces burden of municipal solid waste disposal by 80%–90% is established.
- Effective and efficient collection and transportation mechanism is enforced, which includes collection of partly segregated waste and transportation of waste directly for processing.
- Primary segregation of waste into wet, dry (recyclables), and inert is carried out at household level, while secondary segregation takes place at processing site.
- A dedicated team of 112 people is set up for ensuring a smooth functioning of the system. Each waste collector covers 200–225 households and reports to the supervisor in-charge.
- Routing of each vehicle is optimized so that the collected garbage is directly transferred from trolley to truck to avoid spillage of waste.
- Organic waste is processed into manure through windrow composting for garden waste, and aerobic and drum composting for organic waste from households.
- Tie up with the recycling units or vendors is established for selling of recyclable waste, proper maintenance of logbook, as well as laboratory testing of compost to ensure its quality.
- For smooth system functioning, the supervisor-in charge does regular inspection and maintenance of attendance register of workers.
- User charges are introduced to ensure public participation and financial sustainability of the overall system.
- The Labour Cooperative Society is wholly owned and managed by waste collectors and workers. The cooperative provides front-end waste management services that include door-to-door collection, composting, and recycling.

### **Profit from Waste**

- Approximately 2,078 tonnes of waste is collected from 9,000 households in 2013–2014.
- The waste comprises 1,437 tonnes (69%) organic, 376 tonnes (19%) recyclable, and only 248 tonnes (12%) inert.
- 360 tonnes of organic manure is produced from the collected organic waste.
- The initiative has created direct employment for 112 persons from economically weaker sections.
- Besides covering entire operational cost, the initiative has also generated 12.5% of operational profit in the reference year.

### **Outcomes**

- Overall improvement is achieved in the environment and aesthetic value of the city.
- About 360 tonnes of organic manure is made available for local farmers. It directly contributes in reducing the usage of chemicals in agriculture and in saving of about Rs. 90.00 lakh, which would otherwise have been spent on purchase of chemical fertilisers.
- The system has reduced burden of waste disposal by 88%, and thus also contributes in saving valuable land, fuel, and other costs.

### **Success Factor**

- More than 90% of households directly covered by waste collection.
- Decentralised system.
- Strategic assessment of the existing situation and planning for the collection and safe disposal of the waste.
- Regular monitoring by the team in-charge for ensuring smooth functioning of the system.
- Capacity building of the workers.
- Willingness of citizens to pay a stipulated amount as solid waste collection service.

### **Overall Sustainability**

The integrated waste management initiative of MJS is a self-sustainable model, showcasing the viability of decentralised waste management systems. The operation and management costs are recovered from the user charges collected at Rs. 20–30 per household as well as from the income from sale of recyclable material and manure produced from processing of organic waste.

ITC provided the initial investment as seed money for carrying out this initiative. The SMC, Government of Uttar Pradesh, and Uttar Pradesh State Industrial Development Corporation have provided land for the processing unit and a mini truck for transportation of waste, further strengthening the system.



### 1.4.5.9 ARRANGEMENTS FOR INFORMAL SECTOR INTEGRATION

The informal sector, constituting of both kabadi system and waste pickers, plays an important role in the MSWM value chain by recovering valuable material from waste. It helps reduce environmental impacts by improving resource recovery and reducing disposal requirements. The integration of the informal sector into the formal SWM system will contribute to the reduction of the overall system costs, provide support to the local recycling industry, and create new job opportunities. The waste pickers have significant expertise in sorting municipal waste and are an asset for processing and material recovery facilities.

The informal sector (kabadi system and waste pickers) is the backbone of the MSWM value chain in India, recovering nearly 50% of recyclables generated by households



### Integrating the Informal Waste Sector: Policy Directives

The integration of the informal waste sector into formal waste management systems is made possible through a set of formal or informal arrangements between waste pickers or organisations of waste pickers or organisations working with waste pickers and the local authorities, in their operational area. The integration process would typically result in the accrual of social benefits to waste pickers.”<sup>25</sup>

Some of the salient features of the policies or regulations pertaining to municipal solid waste management (MSWM) as they relate to the informal waste management sector are the following:

- National Environment Policy, 2006. It acknowledges the informal waste sector and states, “Give legal recognition to, and strengthen the informal sector systems of collection and recycling of various material. In particular enhance their access to institutional finance and relevant technologies.”
- National Action Plan on Climate Change, 2009. It stresses the need for giving legal recognition to the informal sector, which it recognizes as the “backbone of India’s highly effective recycling system.”<sup>26</sup>
- National Labour Commission, 2002. It “recognises the useful role played by the scrap collectors both in helping recycling activities as well as in maintaining civic hygiene. It is, therefore, essential that they should be protected from insecurity of various forms. The measures that could be thought of in this regard are providing identity cards, receipts for transactions, minimum wages when they are employed by contractors or other employers, health facilities, creation of welfare funds, prohibition of child labour from the activity and the likes. The Commission fully endorses the suggestions made by the United Nations Development Programme (UNDP) and the International Labour organisation (ILO).”<sup>27</sup>
- SWM Rules, 2016 recognises the role of informal sector in waste management, and emphasise on establishing a system for integration of these waste collectors in order to facilitate their participation in SWM.

Progressive regional legislation that facilitates integration of the informal waste sector into formal systems has been made in some of the Indian states like Maharashtra.

There are various political, legal, cultural, and social conditions that determine the best possible approach to informal sector integration. Local, regional, and national legislative frameworks for informal workers should be considered.

Certain enabling conditions and supportive actions for promoting the integration of the informal sector include:

25 Adapted from Recycling livelihoods – Integration of the Informal Recycling Sector in Solid Waste Management in India Chikarmane, P. L. Narayan, and B. Chaturvedi (2008) and study prepared for GTZ’s sector project “Promotion of concepts for pro-poor and environmentally friendly closed-loop approaches in solid waste management” (unpublished).  
26 National Action Plan on Climate Change (2009).  
27 Second National Labour Commission (2002). Ministry of Labour, Government of India.

Developing formalized material recovery systems is capital intensive. Therefore, informal sectors, if existing, should be encouraged, while ensuring environmental, health and safety safeguards



- organising informal sector into recognised membership-based associations or cooperatives, with true representation of women as part of their leaders and members;
- recognising these associations for MSWM service delivery;
- creating a policy framework for informal waste sector recognition and an inclusive framework to facilitate their participation in the delivery of service;
- promoting social security and health benefits to members of these associations;
- encouraging informal sector, NGO, and CBO through linkage to National Urban Livelihoods Mission;
- providing low-interest loans to organisations of waste pickers seeking to bid for tenders and contracts;
- providing exemptions on fees and deposits for participation of informal sector associations in bidding for MSWM contracts;
- providing basic amenities and facilities for the informal workers to work effectively such as timely wages and bonuses, proper facilities for women to be able to leave their children during work and linkages with community centres or anganwadis, safety and security including PPE, proper redressal mechanisms (for formal complaints, sexual harassment, etc.);
- encouraging informal sector involvement in waste collection and sorting services;
- reserving land in development plans for decentralised processing of biodegradable wastes and collection of recyclables; and
- supporting capacity development programs for informal sector associations (see box below).



#### **Scope for Informal Sector Integration in Municipal Solid Waste Management Activities**

- Door-to-door collection
- Sorting of recyclable waste
- Collection and segregation of recyclable material
- Manual sorting at the conveyor belt in a material recovery facility
- Setup and management of recyclable or reusable waste take-back or buy-back facilities supported by adequate and appropriate skill enhancement arranged for by the urban local body (ULB) or other concerned departments
- Waste sorters in processing facilities (e.g., at the sorting conveyor)



### **Capacity Building and Training of Informal Sector for Providing Municipal Solid Waste Management Services**

- Improvement of managerial skills (business management, accounting, marketing, negotiation skills)
- Maintenance of work ethics and organisation or team work
- Training in sorting, processing, recycling techniques, and value added services
- Formalisation requirements for waste worker organisations
- Environmental and health aspects of waste management activities
- Occupational hygiene and safety
- Business support services linked to large scale formal recycling industries

#### **1.4.5.10 SEGREGATED COLLECTION (DOOR-TO-DOOR COLLECTION, STREET SWEEPING AND DRAIN CLEANING), STORAGE AND TRANSPORTATION**

Door-to-door collection of segregated waste is mandatory as per SWM Rules, 2016. Collection of segregated waste (wet waste, dry recyclables, and domestic hazardous waste), sanitary, horticulture, construction & demolition from residential, commercial, and institutional areas is to be planned by ULBs. Frequency of waste collection is dependent on the quantum of waste generated by each of these groups and the level of segregation of waste. While residential waste is to be collected daily, waste from market area, commercial establishments and institutions may be collected twice a day. The quantum of waste generated and collected also determines the mode of transportation used to collect waste at doorstep. Segregated containers are required for collection of different fractions (wet, dry and domestic hazardous); at a minimum, ULBs shall collect wet and dry waste separately.

Waste collected from doorstep may either be stored in a secondary collection point or transferred directly to secondary collection vehicles (bin-less cities). The feasibility of choosing between secondary storage or direct transfer to secondary collection vehicles is to be ascertained based on the availability of secondary collection vehicles, extent of collection area, and timing of collection. Where waste from all residential areas is collected during morning hours and transferred directly from primary collection vehicles to secondary collection vehicles, the requirement for secondary collection vehicles will be much higher as compared to staggered timings of collection. Wet, dry and domestic hazardous waste should be transported in segregated manner.

The establishment of intermediate transfer stations is determined by the distance between secondary waste collection points and the final

treatment and disposal point. If the distance from the city jurisdiction to the final treatment and disposal points exceeds 15 km, transfer stations may be established.

The choice of secondary collection vehicles is to be synchronised with the design of secondary collection bins and storage containers in the transfer station. Compactors may be used to haul waste from transfer stations to the waste disposal site.

Details on segregated collection and transportation, and choice of containers and transportation systems are given in Section 2.2 and 2.3 of Part II.

#### **1.4.5.11 IDENTIFICATION OF LAND AND INCLUSION IN CITY MASTER PLAN OR CITY DEVELOPMENT PLAN**

Availability of suitable, encumbrance-free land within the ULB's jurisdiction for waste processing and treatment facilities is the biggest challenge faced by the ULBs, which requires detailed deliberation (as mentioned in Table 1.17).

Planning for MSW treatment and processing facilities should begin with the identification of suitable land duly allowing adequate buffer areas, as indicated in Table 1.17. The city master plan and town planning or spatial planning maps should identify and reserve such land for MSWM facilities. The requirement of land is to be calculated based on a tentative assessment of possible disposal options available to the ULB. Land clearance from concerned authorities for establishment of MSWM facilities is to be obtained by the ULB at the earliest possible instance, thereby avoiding inadvertent delays during the implementation process. Siting of MSW processing and disposal facilities should be based on environmental considerations.

**Table 1.17: Criteria for Identifying Suitable Land for Sanitary Landfill Sites**

| <b>S.NO</b> | <b>PLACE</b>   | <b>MINIMUM SITING DISTANCE</b>                                     |
|-------------|--|--|
| 1           | Coastal regulation, wetland, critical habitat areas, sensitive eco-fragile areas and flood plains as recorded for the last 100 years | Sanitary landfill site not permitted within these identified areas |
| 2           | Rivers   | 100 m away from the flood plain                                    |
| 3           | Pond, lakes, water bodies  | 200 m  |
| 3           | Non-meandering water (canal, drainage, etc.)   | 30 m   |

**Table 1.17: Criteria for Identifying Suitable Land for Sanitary Landfill Sites [contd.]**

| S.NO | PLACE                                       | MINIMUM SITING DISTANCE   |
|------|---|---|
| 4    | Highway or railway line, water supply wells | 500 m from center line  |
| 5    | Habitation                                  | All landfill facilities: 500 m  |
| 6    | Earthquake zone                             | 500 m from fault line fracture*   |
| 7    | Flood-prone area                            | Sanitary landfill site not permitted  |
| 8    | Water table (highest level)                 | The bottom liner of the landfill should be 2 m above from the highest water table |
| 9    | Airport                                     | 20 km**   |

km = kilometer, m = meter, MSW = municipal solid waste, TPD = tonne per day.

\* The urban local bodies in seismic zone 4 and zone 5 should consult the seismic fault map before finalizing the site for the sanitary landfill to ensure that seismic factors are taken into consideration in determining the stability of the landfill structure.

\*\* In a special case, landfill site may be set up within 10–20 km away from the airport or airbase after obtaining no objection certificate from the civil aviation authority or air force as the case may be.

#### 1.4.5.12 PROCESS SELECTION AND BEST AVAILABLE TECHNOLOGY FOR PROCESSING AND DISPOSAL

Designing and implementing new waste management systems and optimising existing ones should consider aspects of resource recovery, environmental soundness, financial sustainability, stakeholder involvement and institutional capabilities, in addition to technical and technological appropriateness of systems for handling and disposing waste. This implies that the selection of best MSWM options for a particular ULB goes far beyond a technology selection.

The selection of waste management processes and technology shall be based on the five-tier ISWM hierarchy, which is explained in Section 1.2 of this chapter. The corresponding illustration of the ISWM hierarchy is reiterated in Figure 1.1 for easy reference.

The selection of technology should be based on defined selection criteria and local conditions, subject to a detailed due diligence study. The criteria are listed in Table 1.18 and applied to a number of common strategy and technology options.

In cases where municipal authorities feel challenged to ensure appropriate selection processes, they may seek external expertise to ascertain the most viable solutions.

ULBs should carefully assess unproven technologies and consult the SPCBs to avoid becoming testing grounds for yet to be commercially established technologies



**Table 1.18: Indicative Criteria for Selection of Appropriate Technology or Combination of Technologies<sup>28</sup>**

| CRITERIA                           | WINDROW COMPOSTING   | VERMICULTURE   | BIOMETHANATION   | RDF  | INCINERATION   | INTEGRATED SYSTEM (COM-POSTING + RDF)                          | SANITARY LANDFILL   |
|------------------------------------|--|--|--|--|--|--|---|
| <b>TECHNICAL CRITERIA</b>          |  |  |  |  |  |  |   |
| Facility Location <sup>29,30</sup> | To be located as per the buffer zone criteria mentioned below.   | To be located as per the buffer zone criteria mentioned below. | To be located as per the buffer zone criteria mentioned below. | To be located as per the buffer zone criteria mentioned below. | To be located as per the buffer zone criteria mentioned below. | To be located as per the buffer zone criteria mentioned below. | Landfill sites must be located at least 500 m away from residential areas and should abide by the criteria mentioned in MSW Rules and state level guidelines. |
| Buffer Zone (No Development Zone)  | 500 m for facilities dealing with 100 TPD or more of MSW<br>400 m for facilities dealing with 75–100 TPD of MSW<br>300 m for facilities dealing with 50–75 TPD of MSW<br>200 m for facilities dealing with 10–50 TPD of MSW<br>No buffer zone for facilities dealing upto 5 TPD of MSW<br>No buffer zone for decentralised plants handling less than 1 TPD of MSW (but adequate environmental controls are required) |  |  |  |  |  |   |

<sup>28</sup> Adopted from various sources (JnNURM, World Bank, Task Force Report on Waste to Energy, Planning Commission of India – 2014).

<sup>29</sup> Site selection criteria specified by the EIA Notification 2006 and its amendments shall be considered.

<sup>30</sup> CPCB Guidance on Criteria for Site Selection for Landfills shall also be considered.

**Table 1.18: Indicative Criteria for Selection of Appropriate Technology or Combination of Technologies [contd.]**

| CRITERIA            | WINDROW COMPOSTING  | VERMICULTURE  | BIOMETHANATION  | RDF   | INCINERATION  | INTEGRATED SYSTEM (COM-POSTING + RDF)  | SANITARY LANDFILL   |
|---------------------|---|---|---|---|---|--|---|
| Natural environment | Composting in coastal/high rainfall areas should have a shed to prevent waste from becoming excessively wet and thereby to control leachate generation. | Composting in coastal/high rainfall areas should have a shed to prevent waste from becoming excessively wet and thereby to control leachate generation. |   |   |   |  | Should be avoided in marshy land and in conditions where the ground water table is 2 m from the base of the liner. In marshy land, apart from ground and surface water contamination potential, there could be huge risks due to structural safety of the landfill (slippage and complete breakdown). |
| Land Requirement    | For 300 TPD of segregated/pre-sorted MSW: 5 ha of land including buffer zone is required.   | For 20 TPD of segregated/pre-sorted: 1.25 ha.   | For 300 TPD of segregated/pre-sorted MSW: 2.5 ha of land is required. | For 300 TPD of segregated/pre-sorted MSW: 2 ha of land is required. | For 1000 TPD of mixed waste: 5 ha of land including buffer zone | For 300 TPD of segregated/presorted MSW: 6 ha of land (Note: Many of the processing units are shared). | For 300 TPD of MSW: 30 ha of land is required for 20 years.   |

**Table 1.18: Indicative Criteria for Selection of Appropriate Technology or Combination of Technologies [contd.]**

| CRITERIA  | WINDROW COMPOSTING   | VERMICULTURE  | BIOMETHANATION                                  | RDF                                   | INCINERATION  | INTEGRATED SYSTEM (COM-POSTING + RDF)                                 | SANITARY LANDFILL   |
|---|--|---|---|---------------------------------------|---|---|---|
| Waste Quantity which can be managed by a single facility. | 500 TPD  | 1 TPD to 20 TPD. Higher capacities can also be planned if adequate land is available along with other necessary arrangements. | 1 TPD at small scale to 500 TPD at larger scale | 100 TPD of segregated waste and above | 1000 TPD and above of mixed waste (smaller plants are not techno economically viable, given the cost of required environmental control equipment and boiler technology) | 500 TPD and above (economically sustainable above 500 TPD plant size) | 100 TPD inert and above. Smaller landfills are not techno economically viable |
| Requirement for Segregation prior to technology           | High   | Very high   | Very high                                       | High                                  | High – Feed stock should be free from inerts and low on moisture content  | Moderate because both dry and wet fractions are utilized              | Only inert waste may be placed in landfills as per SWM Rules                  |
| Rejects   | About 30% including inerts if only composting is done. <sup>36</sup> 15%* rejects with RDF, if located in the same plant | About 30% including inerts*   | About 30% from mixed waste*                     | Around 30% from mixed waste**         | Around 15%**  | Approximately 15-20%***   | No rejects  |
| Potential for Direct Energy Recovery                      | No   | No  | Yes   | No (feed stock for energy recovery)   | Yes   | Yes   | Not as per SWM Rules  |

<sup>36</sup> In cases of an integrated facility of composting and RDF, 15% rejects from mixed waste stream is expected

\* Rejects from mixed waste fundamentally depends on the presence of non-biodegradable material which are taken out during pre-sorting stage

\*\* For incoming mixed waste for RDF & Incineration Non combustible material is taken out during the sorting stage

\*\*\* Process rejects from segregated waste should be less than 10%

**Table 1.18: Indicative Criteria for Selection of Appropriate Technology or Combination of Technologies [contd.]**

| <b>CRITERIA</b>     | <b>WINDROW COMPOSTING</b>                        | <b>VERMICULTURE</b>                     | <b>BIOMETHANATION</b>  | <b>RDF</b>  | <b>INCINERATION</b>  | <b>INTEGRATED SYSTEM (COMPOSTING + RDF)</b>  | <b>SANITARY LANDFILL</b>  |
|---------------------|--|---|--|---|--|--|---|
| Technology Maturity | Windrow composting technique is well established | Community scale projects are successful | Feasibility for biodegradable waste is proven. In case of mixed waste, appropriate presorting has to be carried out. | Quality of RDF should be based on end use, no clear consensus on quality requirements. Burning of RDF below 850°C for less than 2 seconds residence time can pose serious problems of health and environment. Rules regulating characteristics of RDF and guidelines for appropriate use not prescribed by concerned authority. | Technology is available. However constraints of low calorific value, high moisture content and high proportion of inert waste should be considered while undertaking the project commercially. | Composting and RDF combined facility is an upcoming phenomenon. Utilisation of rejects from compost plants as input material for RDF production and sale. Rejects from integrated system are 15-20% as opposed to 30-40% from individual system. | Sanitary landfill is a proven method for safe disposal of waste, practiced world over. However it has environmental implications and efforts have to be made to minimize waste going to landfills. MSW Rules only permit inert wastes to be landfilled. |

**Table 1.18: Indicative Criteria for Selection of Appropriate Technology or Combination of Technologies [contd.]**

| CRITERIA                                    | WINDROW COMPOSTING  | VERMICULTURE  | BIOMETHANATION   | RDF   | INCINERATION   | INTEGRATED SYSTEM (COM-POSTING + RDF)   | SANITARY LANDFILL  |
|---|---|---|--|---|--|---|--|
| <b>FINANCIAL CRITERIA</b>                   |   |   |  |   |  |   |  |
| Indicative Capital Investment <sup>37</sup> | Typically 15-20 Cr for 500 TPD plant  | 1 Cr. per 20 TPD  | Typically 75-80 Cr for 500 TPD plant   | Typically 17-20 Cr for 500 TPD plant  | Very high capital, operating and maintenance costs. 15 Cr. per MW power production   | Typically 25-30 Cr for 500 TPD plant) without a mechanical Hot Air Generator (HAG) for drying. However, moisture can be reduced by bio-drying with much less cost but slightly reduced efficiency.  | High   |
| Market for product/ By-Product              | Quality compost compliant with FCO 2013 has a good market. IPNM Task Force (vetted by Supreme Court, 1 Sep 2006) has recommended co-marketing of 3-4 bags of compost with 6-7 bags of inorganic fertiliser. | Good market potential in Urban and Rural areas. However it is not adequately explored for bulk marketing. | So far, there is no appropriate system for pricing biogas. The system of pricing according to kerene equivalent puts biogas at a disadvantage. At present, there is lot of interest in conversion of biogas into automotive fuel by stripping CO <sub>2</sub> . In this case, equivalent pricing with power/CNG again puts biogas at a disadvantage because of scale of economy. | Good market potential for RDF. In small cities, RDF plants only become feeders of large RDF based power plants and cement plants. | Good potential of energy generation if power purchase agreements are made reflecting true cost of production including O&M costs | Quality compost compliant with FCO 2009 has a good market. Good market potential for RDF. In small cities, RDF plants only become feeders of RDF to large RDF based power plants and cement plants. | No potential, since it is stipulated by the SWM Rules that only inert wastes are to be disposed in landfills |

37 Toolkit for Solid Waste Management (2012), Jawaharlal Nehru National Urban Renewal Mission, Ministry of Urban Development, Government of India. <http://jnurm.nic.in/wp-content/uploads/2012/11/SWM-toolkit.pdf>

Table 1.18: Indicative Criteria for Selection of Appropriate Technology or Combination of Technologies [contd.]

| CRITERIA   | WINDROW COMPOSTING   | VERMICULTURE  | BIOMETHANATION  | RDF   | INCINERATION   | INTEGRATED SYSTEM (COM-POSTING + RDF)  | SANITARY LANDFILL  |
|--|--|---|---|---|--|--|--|
| <b>MANAGERIAL CRITERIA</b>                       |  |   |   |   |  |  |  |
| Labour Requirement                               | Labour intensive   | Labour intensive  | Less labour intensive   | Labour intensive (based on current practice). | Non labour intensive but requires considerable technical capacity, | Labour intensive but requires considerable technical capacity.   | Only inert wastes are to be deposited in sanitary landfills. Labour intensive but requires considerable technical expertise as well. |
| Predominant skills for Operation and Management. | Technically qualified and experienced, and semi-skilled staff..  | Technically qualified and experienced, and Semi-skilled staff <sup>38</sup> .   | Technically qualified and experienced staff.  | Technically qualified and experienced staff.  | Technically qualified and experienced staff.                       | Technically qualified and experienced staff and semi-skilled.  | Technically qualified and experienced, and semi-skilled staff.   |
| <b>ENVIRONMENTAL CRITERIA</b>                    |  |   |   |   |  |  |  |
| Concerns for toxicity of product                 | The final product is generally applied to soil and used as manure. Can contaminate the food chain if compost is not meeting FCO norms. | The product is generally safe as worms cannot endure significant contamination of raw materials. FCO Standards are to be met with | The final product is generally applied to soil as a soil conditioner. Can contaminate the food chain if compost is not meeting FCO norms. | -   | -  | The final product is generally applied to soil and used as manure. Can contaminate the food chain if the compost is not meeting FCO norms. | -  |

38 On-site training is required for unskilled labour, as a minimum requirement for efficient operation



**Table 1.18: Indicative Criteria for Selection of Appropriate Technology or Combination of Technologies [contd.]**

| CRITERIA           | WINDROW COMPOSTING  | VERMICULTURE  | BIOMETHANATION                           | RDF        | INCINERATION  | INTEGRATED SYSTEM (COM-POSTING + RDF)   | SANITARY LANDFILL  |
|--------------------|---|---|--|------------|---|---|--|
| Leachate Pollution | <p>Potential exists. Varies with the climate of area and seasonal variation. In relatively dry seasons, leachate can be recirculated into the windrow to contain loss of nutrients and also pollution potential.</p> <p>In high rainfall areas, the windrows need to be covered either temporarily or permanently to control leachate generation. However, the design of the shed should be such that good natural ventilation is maintained.</p> | <p>Insignificant quantities at low waste volumes per vermi-pit.</p> | <p>High if not treated appropriately</p> | <p>Low</p> | <p>High potential of leachate at the receiving pit.</p> | <p>Potential exists for compost</p> <p>Varies with the climate of area and seasonal variation. In relatively dry seasons, leachate can be recirculated into the windrow to contain loss of nutrients and also pollution potential.</p> <p>In high rainfall areas, the windrows need to be covered either temporarily or permanently to control leachate generation. However, the design of the shed should be such that good natural ventilation is maintained.</p> | <p>Polluted surface runoff during wet weather, groundwater contamination due to leachate infiltration</p> <p>Moderate to high depending upon the leachate recycling and control systems.</p> <p>Leachate management during monsoons requires special attention</p> |

Table 1.18: Indicative Criteria for Selection of Appropriate Technology or Combination of Technologies [contd.]

| CRITERIA              | WINDROW COMPOSTING                         | VERMICULTURE                               | BIOMETHANATION                              | RDF  | INCINERATION  | INTEGRATED SYSTEM (COMPOSTING + RDF)   | SANITARY LANDFILL  |
|-----------------------|--|--|---|--|---|--|--|
| Atmospheric pollution | Low (dust, aerosol etc.).<br>Odour issues. | Low.<br>Odour issues.                      | Low.<br>Leakage of biogas.<br>Odour issues. | Low to moderate (dust, aerosols).<br>Very high if RDF is not burnt at required temperature.<br>Odour issues.         | Very high if emissions not managed properly.<br>Fly ash should be disposed safely in an engineered landfill.<br>(Emissions due to incomplete combustion of municipal refuse contain a number of toxic compounds, dioxins and furans, requiring appropriate emissions control systems) | Moderate, require appropriate emission control systems (Air emission include acid gases, dioxins and furans).        | Air pollution and problems of odour and methane emissions if not managed properly.                         |
| Other                 | Fire and safety issues to be taken care of | Fire and safety issues to be taken care of | Fire and safety issues to be taken care of  | Presence of inappropriate material in the RDF (chlorinated plastics).<br>Fire and safety issues to be taken care of. | Disposal of bottom ash/ slag.<br>Fire and safety issues to be taken care of.  | Presence of inappropriate material in the RDF (chlorinated plastics).<br>Fire and safety issues to be taken care of. | Spontaneous ignition due to possible methane concentration.<br>Fire and safety issues to be taken care of. |

\*Actual planning and implementation will also depend on engineering and installation of plants

Further detailed information on the different technologies and their implementation requirements are to be found in sections 3.2 to check 3.5 of chapter 3 of Part II of this manual.





### 1.4.5.13 PLANNING FOR EFFECTIVE COMMUNITY PARTICIPATION THROUGH INFORMATION, EDUCATION AND COMMUNICATION

An efficient waste management program, regardless of the strategy, requires significant cooperation from waste generators and active community participation.

Information, education, and communication (IEC) is a multilevel tool for promoting and sustaining risk-reducing behaviour change in individuals and communities. The decision to adopt new ideas or behaviour is the result of a complex process and takes place only over a period of time. Development and implementation of an IEC campaign involves planning and implementing a comprehensive, strategic set of interventions and activities to change behaviour at many levels to achieve the objectives of the MSWM plan.

Awareness and education campaigns are essential to bring about a behavioural change among the citizens in managing their waste. The IEC campaign should not only target households, shops, and commercial and institutional premises, but also all other stakeholders such as municipal officials, elected representatives, schools, non-government organisations (NGOs), the informal sector, media, etc. to ensure their participation in managing city waste by discharging their role effectively.

An IEC campaign is not a single time activity; on the contrary, depending on the stage of planning or implementation, constant communication with the community and all relevant stakeholders is necessary.

A sustained campaign of targeted messages, relevant to the ongoing planning or implementation phase specific to each considered social group, will result in bringing about a significant change in behaviour patterns.

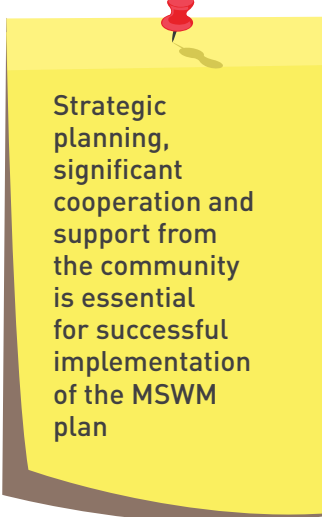

Strategic planning, significant cooperation and support from the community is essential for successful implementation of the MSWM plan

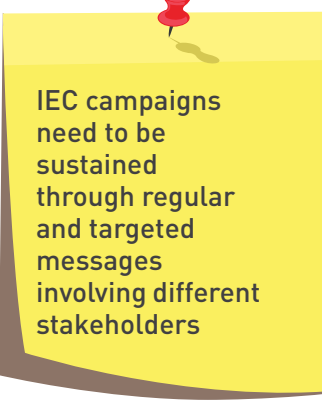

IEC campaigns need to be sustained through regular and targeted messages involving different stakeholders



#### Community Participation as an Accelerator for Efficient Municipal Solid Waste Management

Communities should:

- actively participate in waste reduction, reuse, and recycling;
- stop littering the streets, drains, open spaces, and water bodies;
- practice segregation of waste at source into biodegradable (wet) and nonbiodegradable (dry) waste, ensuring that other wastes belonging to the 'special' category are handed over separately;
- participate in primary collection of waste through resident welfare associations (RWAs), self-help groups (SHGs), non-government organisations (NGOs), or individual waste collectors by paying for the services;
- encourage and assist in local composting and recycling initiatives; and
- promote effective provision of municipal solid waste management (MSWM) services for low-income populations.

### 1.4.5.13.1 Communicating the Municipal Solid Waste Management Plan

Successful implementation of the MSWM plan is dependent on its ownership by multiple actors. Periodic and timely dissemination of various facets of the MSWM plan would bring a significant change in human behaviour. This in turn will improve the standard of cleanliness in the city and give a better quality of life to the citizens.

Rapid assessment of the existing MSWM situation in city's ward or community enables ULBs to identify key community behaviour patterns that could aid or impede the implementation of the plan. The communication campaign should seek to change undesirable practices and strengthen complimentary habits.

Strengthening and clarifying the roles of key actors within and outside the ULB should be a key outcome of a communication plan (Table 1.19).

All households, commercial establishments, and other institutional premises have to be reached through IEC campaign to cooperate with the municipal authority in managing their waste. This can be achieved through intermediaries such as resident welfare associations (RWAs), community-based organisation (CBOs), non-government organisations (NGOs), self-help groups (SHGs), and social organisations along with the elected representatives and municipal officials. Impacts of gender vulnerability and issues of poverty are essential dimensions that must be considered in all communications.

Modes of communication chosen for the IEC campaign should be accessible by the target audience, easily replicable, and cost-effective. Several modes of communication should be simultaneously used to communicate the plan. The integrated use of multiple modes increase the coverage, frequency, and impact of communication messages.

#### Typical Modes of Communication

##### Print Medium:

While the print medium is more appropriate for the literate class, visual impact of the print medium should also be used to reach out to all sections of the community. For the illiterate, messages can be conveyed pictographically in print. The messages conveyed should be clear and easily comprehensible. Messages on product reuse, recycling, and disposal can be printed on all products used by the community.

**Table 1.19: Stages of Municipal Solid Waste Management Plan Implementation – Objectives and Target Audience**

| MSWM ISSUE                    | TARGET AUDIENCE  | OBJECTIVE  |
|-------------------------------|--|--|
| Generation                    | All waste generators in the city including informal settlements and floating population  | <ul style="list-style-type: none"> <li>Reduce amount of waste generated</li> <li>Promote reuse and recycling</li> </ul>  |
| Littering                     | Community  | Prevent open littering by communicating penalties for littering  |
| Burning of waste              | ULB staff, community, floating population (focus on informal workers, low income group localities)   | <ul style="list-style-type: none"> <li>Prevent burning of waste as a disposal option</li> <li>Dissuade and prevent open burning of waste for heating (in cities with harsh winters)</li> </ul>   |
| Waste segregation             | All waste generators: households, commercial establishments, institutions, ULB staff   | <ul style="list-style-type: none"> <li>Communicate importance of waste segregation in ensuring sustainable management of waste, performance of processing and treatment systems, and health and environmental aspects</li> </ul>   |
| Door-to-door collection       | <ul style="list-style-type: none"> <li>Waste generators serviced by door-to-door collection (e.g., households, commercial establishments, markets, institutions, etc.)</li> <li>ULB staff, NGOs, RWAs, etc. responsible for door-to-door collection</li> </ul> | <ul style="list-style-type: none"> <li>Provide information on level of segregation required</li> <li>Provide information on waste collection schedule for different waste fractions (where applicable)</li> <li>Provide information on timings of collection</li> </ul>  |
| Secondary collection          | <ul style="list-style-type: none"> <li>Agencies involved in transportation of waste</li> <li>Sanitary inspectors and other MSWM department staff</li> </ul>  | <ul style="list-style-type: none"> <li>Ensure segregated transportation of waste as per MSWM plan</li> <li>Ensure adoption of best practices, efficient transportation of waste to avoid illegal dumping and malpractices</li> </ul>   |
| Transportation                | Agencies involved in transport of waste, sanitary inspectors and other solid waste management department staff involved in providing or monitoring these services  | <ul style="list-style-type: none"> <li>Ensuring segregated transportation of waste as per MSWM Plan</li> <li>Ensuring adoption of best practices to ensure efficient transportation of waste, avoiding illegal dumping and malpractices in waste transportation</li> </ul>   |
| Waste treatment or processing | <ul style="list-style-type: none"> <li>Community</li> <li>MSWM department staff</li> <li>Agencies, NGOs, and formal and informal recyclers</li> <li>involved in solid waste processing oof treatment</li> </ul>  | <p>Dissemination the following:</p> <ul style="list-style-type: none"> <li>Information on need for segregation for improved efficiency of waste treatment and processing</li> <li>Information on planned treatment and processing facilities</li> <li>Information on environmental safeguards in MSWM treatment and processing</li> <li>Information on monitoring requirements</li> <li>Periodic information on analysis of monitoring data</li> </ul> |
| Waste disposal                | <ul style="list-style-type: none"> <li>Community</li> <li>MSWM department staff</li> <li>Agencies, NGOs, and formal and informal recyclers involved in solid waste disposal</li> </ul>   | <ul style="list-style-type: none"> <li>Disseminate the following:</li> <li>Information on waste disposal plans of the ULB</li> <li>Information on environmental safeguards in MSWM disposal facilities</li> <li>Information on monitoring requirements</li> <li>Periodic information on analysis of monitoring data</li> </ul>   |

### **Audiovisual Medium:**

Audiovisual communication has a large coverage and long-lasting impact; it has proven successful in influencing attitudes and motivating behaviour change. A sustained campaign on sanitation and hygiene-related issues is possible through partnerships with local radio and TV stations. The electronic media tends to overcome all barriers of illiteracy. Catchy jingles on specific issues tend to grab the attention of the audience and have a higher recall compared with conventional advertisements.

### **Internet:**

Interactive websites can prove to be an effective mode to communicate with children, college students, and the working class. Interactive websites focused on sanitation and hygiene can be hosted by the local authority. Such websites should:

- highlight services offered by the local authority;
- showcase extended producer responsibility (EPR) initiatives;
- include frequently asked questions (FAQ) in question and answer format;
- accept queries or comments;
- provide information about various waste management workshops in the city;
- host existing waste regulations in a form easily understood by common people;
- host a facility for lodging complaints;
- highlight innovative waste management or waste to resource initiatives;
- provide links to research for more information on certain waste-related topics, which can keep on changing according to the stage of the MSWM plan implementation in the local authority;
- provide guidance documents and case studies of best practices; and
- provide inventory of recyclers and waste management solution providers, as applicable.

### **Social Media:**

Social media is being effectively used by progressive ULBs for interacting with the community and communicating city level waste management practices. ULBs, through their presence on interactive social media such as Facebook and Twitter, encourage the community to report on specific issues, include visual representations of issues, communicate with the community in real time, and provide updates once the issue is resolved. Such tools assist ULBs in easy and quick identification of local issues and encourage fast resolution of issues.

## Interpersonal:

Interpersonal communication involving persuasive dialogues and discussions with individual members of the household especially during door-to-door visits has been the most effective communication tool within the IEC framework. Local SHGs, slum level federations, town level federations, and sanitation workers should be involved in such communication.

Sanitation workers involved in door-to-door collection have proven to be the most important link in sustaining the efforts for segregating waste e.g., Pune and Kochi. All new residents coming to a city should be educated in the MSW system prevalent in the city as they tend to spoil the segregation chain due to lack of knowledge.

## Others:

Organising rallies, walkathons, or local contests will raise media interest and help carry sanitation messages to communities. Possible formats like Swachhta Shapath (cleanliness pledge), Cleanliness Drive, and other similar events may also be used to raise awareness. Special annual events can be created to refresh awareness or to award communities or households for their performance. Tools of communication like musical or dance dramas, puppet shows, street plays, etc. may also be used.

Awareness activities for school children bring about the longest impact and result in quickly visible and sustained changes in the society. Children are active communicators and have convincing powers. It is also easier to modify behaviour of children through information sharing, increasing knowledge base, and motivation. Regular meetings should be held with school authorities for organising school activities on hygiene and sanitation issues. Appropriate activities as per age and class of children may be taken up in schools. Activities which engage both young boys and girls should be encouraged, as these activities contribute significantly to healthy socialisation. Negative gender roles and stereotypes must be discouraged.

Once the target group and mode of communication is selected, a detailed action plan—including an exact timeframe, stakeholders, financial outlay, and proposed outcomes of the awareness campaign— should be developed, implemented, and monitored. The ULBs can use the work plan to monitor activities and the progress of its awarenessraising campaign. Resources (institutional and financial) should also be identified to support plan implementation. The programme should be monitored through an assessment of indicators for behavioral change and other targeted impacts.



Interpersonal communication is the most effective communication tool, e.g., individual counselling, community level interaction, motivation sessions, small group discussions, peer education, and door-to-door visits



School children should be primary targets of IEC campaigns, as they are major agents of societal change



### Developing Capacities for Implementing Awareness-Raising Campaigns

The following are some ways to develop capacities of urban local body (ULB) staff, non-government organisations (NGOs), self-help groups (SHGs), and other communitybased organisations (CBOs) for implementing awareness-raising campaigns:

- Indicate the issues to be covered as per social and cultural needs or requirements.
- Draft messages for selected media.
- Field-test draft material and finalize material with selective target groups (including women, youth, and children).
- Train the field workers or ULB staff.
- Train NGOs and SHGs in facilitating municipal solid waste management (MSWM).
- Monitor progress in the field.



### Package of Information, Education, and Communication Material<sup>39</sup>

The following information, education, and communication (IEC) tools are suggested in municipal solid waste management (MSWM):

- Dance, drama, puppetry, and street plays can be used as part of long term strategies.
- These can also be used for information dissemination in residential colonies.
- Short films clearly indicating do's and don'ts with respect to municipal solid waste management can be prepared for the benefit of citizens and MSWM department staff .
- A wall magazine or poster can be prepared for information and dissemination in schools and offices.
- Drawing and essay competitions on MSWM for school students should be arranged with prize incentives.
- Programs should be arranged by involving celebrities. Female celebrities can bring about specific awareness on women-related issues, sanitary issues, etc.
- Cooperation of spiritual leaders should be sought for propagation of the messages for proper MSWM.
- Municipal agencies, while licensing fairs and festivals, etc., should insist on the organizers to provide the banners with MSWM messages.
- All hoardings should carry a prominent line seeking cooperation of the citizens in maintaining the city clean.
- A logo, mascot, or slogan regarding the importance of keeping cities clean should be coined or framed with the help of expert agencies. This should be widely adopted.
- Literature on best practices should be prepared and distributed to the citizens.
- Notebooks for school children printed through government agencies should carry the message of cleanliness campaigns.
- Small booklets to serve as a ready reckoner on MSWM should be prepared.
- Magic shows or simple magic programme should be popularized to propagate the ideas.
- Messages can be widely distributed by printing them on milk pouches, T-shirts, etc.

Source: Government of India, Ministry of Urban Development, Central Public Health and Environmental Engineering Organisation. 2005. Report of the Technology Advisory Group on Solid Waste Management. New Delhi.

<sup>39</sup> Report of the Technology Advisory Group on Solid Waste Management (2005).

## 1.4.6 STEP 5: SCHEDULE FOR IMPLEMENTATION

Figure 1.12: Step 5: Schedule for Implementation

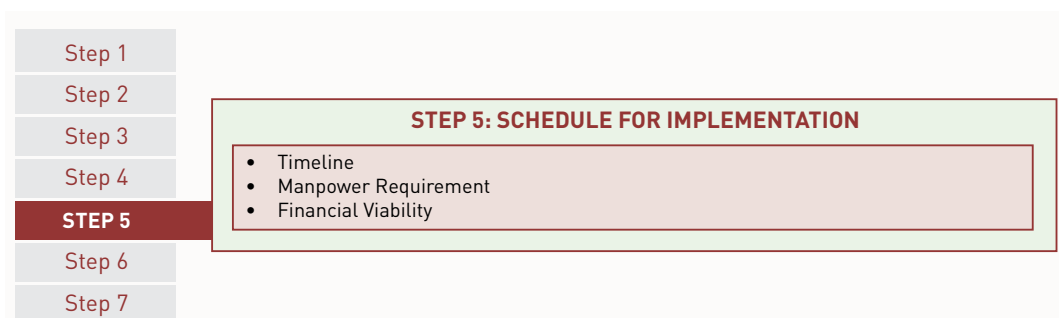

The MSWM Plan should address short term (5 years) and long term planning periods (20-25 years). The short term plan should lead to the achievement of the long term plan. Each short term plan should be reviewed every 2-3 years, to ensure higher success of implementing all plan activities. Based on the identification of service levels to be achieved during the short term, a detailed time plan should be prepared for actions to be undertaken in each year. The implementation plan should also include a detailed estimate of required human resources and investments.

Short term (5 years) plans should contribute to the achievement of the long term plan

Figure 1.13: Components of the Municipal Solid Waste Management Plan

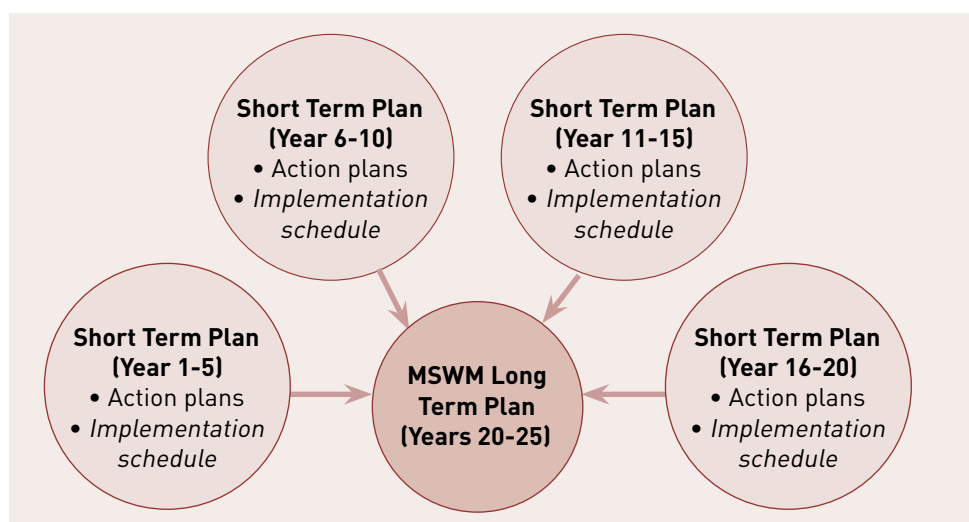

Long term (20–25 years) plan typically constitutes 4–5 short term planning cycles

The long term plan should be further drilled down to identify short term action plans associated with time lines for implementation. Each long term plan will typically consist of 4–5 short term planning cycles. Actions to be undertaken in each of these planning cycles should be clearly identified.

The five-year short term plan (Figure 1.14) may be broken up into specific action plans covering various aspects such as institutional

strengthening, community mobilisation, waste minimisation initiatives, waste collection and transportation, treatment and disposal, and other policy changes as may be deemed necessary. The financial outlay required for each action plan should be elaborated, and sources of finance ascertained in the planning phase. Financial planning also has a direct impact on the contracting mechanisms to be adopted.

Multiyear actions should be further elaborated yearly, with a cost attached to each year's implementation. Clear definition of the roles of various stakeholders and adequacy of requisite staffing should be ascertained.

ULBs may need to enhance the technical capacity of MSWM staff to execute the MSWM plan in a financially viable and sustainable manner. A detailed yearly and equitable staffing capacity and training requirement should be prepared, and any identified gaps should be filled before action plan implementation.

**Figure 1.14: Components of a Short term Plan**

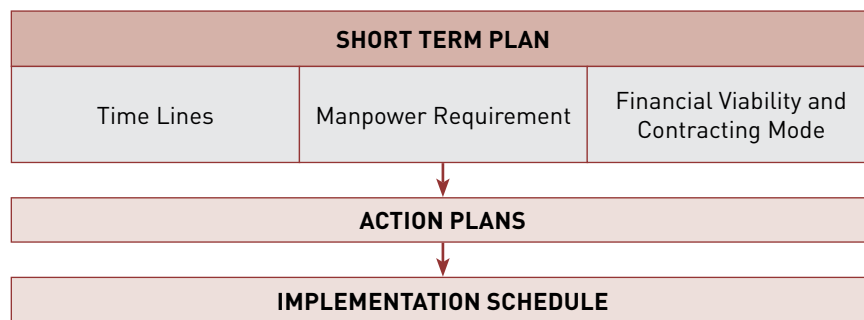

### 1.4.7 STEP 6: STAKEHOLDER CONSULTATION FOR MUNICIPAL SOLID WASTE MANAGEMENT PLAN VALIDATION

**Figure 1.15: Step 6: Stakeholder Consultation for Municipal Solid Waste Management Plan Validation**

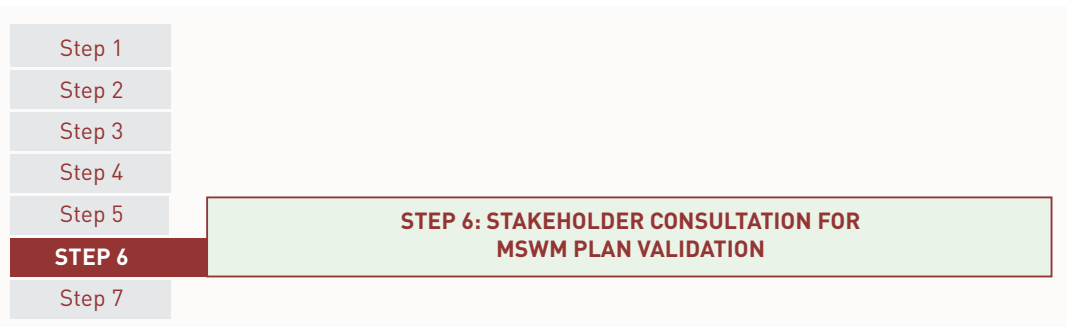



The draft MSWM plan, complete with action plans and an implementation schedule, is to be presented to and accepted by the stakeholder committee which provided inputs to the draft plan (Step 3 of the planning process).

Based on the feedback of the stakeholder team, further revisions to the plan may be required.

#### 1.4.8 STEP 7: MUNICIPAL COUNCIL APPROVAL FOR MUNICIPAL SOLID WASTE MANAGEMENT PLAN AND PLAN IMPLEMENTATION INCLUDING PUBLIC PRIVATE PARTNERSHIP

After due consideration of the recommendations of the stakeholder committee, the revised plan is to be submitted to the city council of the ULB or equivalent body for its validation and adoption as an official plan.

The city council should concur with the provisions of the plan including proposed tariff and revenue collection mechanisms, modes of engagement of private sector, implications on existing and proposed municipal staff, and proposed locations of waste management facilities.

Changes to any of these elements of the plan would have larger implications on the viability of the plan and should be duly noted and addressed before finalisation of the plan. The final plan should be clearly communicated and presented to the council for final ratification.

City council ratification of the MSWM plan, along with an agreed implementation schedule, is vital for future implementation

Figure 1.16: Step 7 in Municipal Solid Waste Management Plan



Subsequent chapters give details of technical aspects required for developing and implementing an MSWM plan. Further details of plan implementation and monitoring of service provision are detailed in Chapter 5 and Chapter 6.

#### 1.4.9 ACTION POINTS FOR AWARENESS GENERATION THROUGH INFORMATION, EDUCATION, AND COMMUNICATION ACTIVITIES FOR MUNICIPAL SOLID WASTE MANAGEMENT PLAN IMPLEMENTATION BY THE URBAN LOCAL BODY



Stakeholders include households, businesses, industries, informal sector, the local government, NGOs, CBOs, SHGs, women's groups, school and college students, and members of other relevant institutions

Citizen's involvement in MSWM plan preparation through a formalised stakeholder committee is necessary. Ensuring community participation can be done through:

- willingness of stakeholders to cooperate in the operation and management of MSWM services;
- awareness on the type of service and frequency;
- knowledge of source segregation (number of waste fractions, issues of collection of recyclables, reuse, etc.);
- awareness of final treatment and disposal information;
- inclusion of different sections of society such as rag pickers, municipal workers, and entrepreneurs; and
- dissemination of information on service charges or user fees, the mode of payment, and the frequency of payment.





## **Technical Aspects:**

Segregation,  
Collection and  
Transportation

## IN THIS SECTION

|     |  |     |
|-----|--|-----|
| 2.1 | Waste Minimisation (At Source Reduction and Reuse)   | 127 |
| 2.2 | Source Segregation   | 134 |
| 2.3 | Collection and Transportation  | 155 |
| 2.4 | Street Cleaning  | 189 |
| 2.5 | Action Points for Awareness Generation Through Information, Education, and Communication Activities for Efficient Segregation, Collection and Transportation | 206 |

## 2. TECHNICAL ASPECTS: SEGREGATION, COLLECTION AND TRANSPORTATION

### 2.1 WASTE MINIMISATION (AT SOURCE REDUCTION AND REUSE)

#### 2.1.1 SOLID WASTE MANAGEMENT RULES, 2016 - REQUIREMENTS ON WASTE MINIMISATION

As per the SWM Rules, 2016, the ULB should create public awareness for minimising waste generation and reusing waste to the extent possible. Source reduction is the most preferred tier in the ISWM hierarchy because of its potential to directly reduce the quantity of waste generated and hence reduce associated financial and environmental costs.

#### 2.1.2 WASTE MINIMISATION IN INTEGRATED SOLID WASTE MANAGEMENT HIERARCHY

The ISWM (Integrated Solid Waste Management) hierarchy of waste management prioritises waste minimisation (reduction at source and reuse) as the most preferred waste management strategy (Figure 2.1).

Figure 2.1: Waste Minimisation in the ISWM Waste Hierarchy<sup>1</sup>

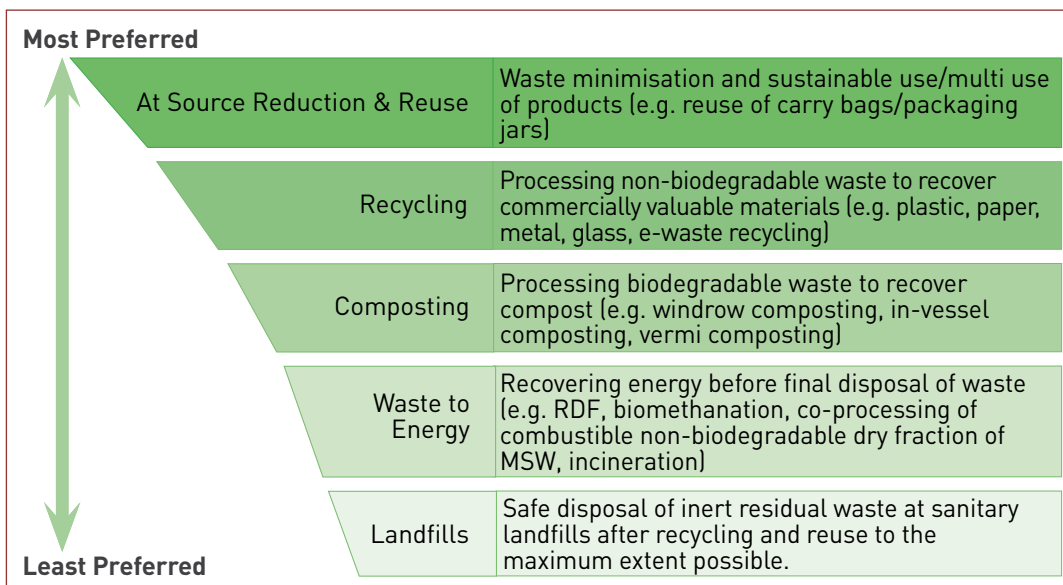

Waste minimisation results in reducing the amount and toxicity of the wastes produced. Minimisation is the most preferred waste management strategy in the hierarchy as it reduces the quantity of waste to be handled, the cost associated with its handling, and its environmental impacts.

Waste minimisation includes activities that reduce waste generated as a result of product creation and use. It also encompasses those activities that increase product durability, reusability and reparability

<sup>1</sup> Developed by the Expert Committee for revision of MSWM manual (2013-15)

### 2.1.3 NEED FOR AND BENEFITS OF WASTE MINIMISATION

Of the 1,43,449 tonnes per day (TPD)<sup>2</sup> of MSW generated in 2014–2016 in India, 40%–60% is organic and 10%–20% recyclable. The associated cost for processing and disposing is 80%<sup>3</sup>. This is assuming that 20% is recycled and does not enter the MSW stream to be processed. This waste, at an average cost of Rs. 1,000 per tonne, is approximately Rs. 10.7 crore per day. Waste minimisation results in savings, which accrue through avoided collection, treatment, and disposal costs.

Reduction in the use of environmental and material resources accrues as a result of waste minimisation programmes. In addition, the rapidly decreasing land bank in urban areas, rising costs of procuring land for processing and disposal, and associated environmental impacts are all significant reasons to promote waste minimisation. Disposal of waste results in large scale emissions of greenhouse gases like methane and carbon dioxide. Waste minimisation would lead to a reduction in greenhouse gas emissions and associated climate change impacts.

### 2.1.4 STRATEGIES FOR WASTE MINIMISATION

Waste minimisation strategies require policy interventions at the National, State and local level, depending on the type of the intervention and the scale at which the intervention needs to be initiated for effective implementation. For example introduction of the national deposit system on beverage packaging, buy-back mechanisms for reusable or recyclable packaging material, promoting the use of refill containers etc. Initiatives which require a behaviour change in the community need to be supported by consistent awareness programmes.

#### 2.1.4.1 WASTE MINIMISATION STRATEGIES REQUIRING A NATIONAL OR STATE LEVEL DIRECTIVE

Extended producer responsibility (EPR) is a policy approach wherein a producer is held responsible for the post-consumer stage of a product, typically for defined tasks of separate collection (e.g., for hazardous waste components like e-waste), reuse (e.g., deposit–refund systems for bottles), recycling (e.g., for used cars), and storage and treatment (e.g., for batteries). EPR programmes require a national or state level directive. They are commonly made mandatory through legislation, but can also be adopted voluntarily (i.e., retail take-back programmes).



Source reduction could include various strategies such as EPR, tax incentives and eco-labelling. Establishment of eco industrial parks with adequate emphasis on recycling industries can support source reduction

2 Status report on MSWM (2014–15).

3 This is assuming that 20% is recycled and does not enter the MSW stream to be processed.



The advantages of EPR systems include:

- reduction in natural resource demands of packaging and product containers;
- creation of incentives for environmentally friendly product designs;
- reduction in waste disposal costs for ULBs;
- provision of a monetary incentive to the consumer to return the product or package; and
- creation of infrastructure for collection and recycling of material.

EPR is currently practised for waste fractions generating from electronics, batteries, packaging, and consumer durables (e.g., home appliances, electronics, and home and office furniture) for their appropriate and safe disposal. EPR policies are usually legislated at state and national levels.

Typical EPR tools include:

- Deposit refund systems
- Quotas
- Product bans
- Product charges
- Collection systems



#### Typical EPR Tools<sup>4</sup>

**Deposit–refund systems.** These are required in the beverage container deposit legislation or “bottle bills”. Producers charge the consumers an additional disposal fee, which is refunded upon receiving the used container. In the beverage industry, the manufacturers collect from the consumers used glass bottles and aluminium cans (e.g., soft drink cans and glass bottles and large mineral water containers) and refund the deposit. The manufacturers also take back lead acid batteries through the deposit–refund system. In 2003, Germany introduced a mandatory deposit–refund system for certain one-way beverage packaging, which is defined as ecologically disadvantageous, to discourage this packing in the market.

- **Quotas.** Government authorities stipulate that a certain percentage of product content or packaging should be from recycled material. For instance, Germany has set a requirement in its previous packaging ordinance that 72% of beer and soft drink containers should be refillable. If the quota is not achieved, a mandatory deposit system will be enforced. Through an amendment of the ordinance, most beverage one-way containers are subject to the mandatory deposit system.
- **Product bans.** The threat of product bans motivates producers to phase out undesirable materials, design for recyclability, and ensure high rates of reuse or recycling. For example: In Sweden, the voluntary deposit system for aluminium cans results in achieving the government mandated recycling rate. The driver behind Sweden’s successful voluntary deposit system for aluminium cans is the “can ban” that may ensue if the rates fall below the recycling rate set by government.
- **Product charges.** Product charges influence the choice of materials used. An eco-tax levied on polyvinyl chloride (PVC) in Belgium increased the cost and reduced consumption of this polymer.

“Godrej” has a ‘No Packaging Policy’ for refrigerators’. The company ensures that the packaging, in which the appliance is delivered, is taken back by the supplier and reused

4 “Extended Producer Responsibility: Container Deposit Legislation Report”, Zero Waste New Zealand (2002). <http://www.zerowaste.co.nz/assets/Reports/Beveragecontainers.pdf>

- **Collection systems.** Producers and the retail trade can be made responsible for taking back packages and used products such as batteries and compact fluorescent lamps (CFLs). Germany, in 1991, adopted the first packaging ordinance which makes industry responsible for collecting packages.

In India, the informal sector (kabadi system or scrap dealer) is largely involved in collection of recyclables and material recovery. EPR initiatives, which encourage informal sector participation in collection of recyclables from consumers, benefit from the increased collection efficiency that this sector is able to achieve, which may then result in lower supply chain costs (collection costs).

Additionally, the National or State Government can promote initiatives which would encourage adoption of waste minimisation oriented practices:

- Promotion of voluntary action by encouraging business groups to reduce volumes of packaging, while maintaining the requisite strength.
- Authorising urban local bodies to frame rules and local bye-laws and enact local ordinances banning use or sale of certain types of products and packaging that cannot be reused, repaired, recycled, or composted. National or State level legal frame work and policy should also mirror such ordinances, to better enable local authorities to enforce such ordinances, laws and rules.
- Develop eco-labeling standards based on potential for waste reduction due to product packaging and potential for recycling and reuse.
- Promote development of eco-industrial parks, which are industrial areas where in material and resource exchange synergies, are established between businesses and industries. Such parks might operate facilities for recycling and product reuse processes.



Shimla City was able to effectively enforce a full ban on plastic carry bags only when the Government of Himachal Pradesh passed a legislation on banning their use. The state government has also enforced a ban on non-biodegradable packaging for 25 kinds of edible foodstuff, forcing perishable food manufacturers to adopt biodegradable packaging.

#### 2.1.4.2 WASTE MINIMISATION INITIATIVES REQUIRING URBAN LOCAL BODIES SUPPORT

- Promoting and implementing awareness and education programmes addressing different stakeholders e.g., residential, commercial and industrial educational programmes that increase public awareness and participation, in at source reduction programmes.
- Developing and promoting at source reduction programmes in the community, e.g. domestic composting programmes that reduce the volume of food waste, leaves and garden trimmings entering the collection system.
- Campaigns for reducing the use of specific non-recyclable, non-reusable or toxic material. Practicing and promoting material substitution where possible. (Promoting the use of rechargeable batteries instead of single use batteries)
- Bans within local authorities' jurisdiction (see also National or State level initiatives above) through replacing disposable materials and products with recyclables and reusable materials and products (e.g. banning the use of plastic bags).
- Green procurement and take back programmes, whereby the suppliers of a product to the municipality are responsible for providing a take back programme and to promote the recycling of e.g. computer monitors, auto oil, batteries, paper etc. Procurement programmes in the government and businesses should be designed to give preference to recyclable products.
- Local businesses should be encouraged to reward consumers for returning recyclable products or products which are toxic (e.g. batteries). EPR programmes by manufacturers are a pre-requisite to these initiatives. (see Section 2.1.4.1 of Part II).
- Educational and on-site business and industry assistance programmes should be promoted that advise businesses on how to use materials more efficiently and reduce waste generation.



##### Examples of Onsite Business Assistance Programmes

- Reducing office paper waste by making training manuals and personnel information available electronically and by implementing a formal policy to print double sided for all draft reports and, if possible, all final documents.
- Improving product design to use less material.
- Redesigning packaging to eliminate excess material while maintaining strength.
- Working with customers to design and implement a packaging return programme .
- Switching to reusable transport containers.
- Purchasing products in bulk

In many international communities, household waste disposal fee is directly proportional to the quantity of waste disposed, helping achieve segregation at source

- Supermarkets and retail stores are often some of the most effective partners for a municipal waste minimisation programme. These provide a central & consistent point for consumer education, packaging reduction projects and collection centers for recyclable waste.
- Promoting materials exchange and reuse programmes that divert material from the waste streams which will eventually go to the landfills, e.g., programmes which link sellers of used furniture with potential second hand furniture buyers.
- Establishing incentives for at-source reduction through the principle of “pay as you throw”, supported by bye-laws. Urban local bodies can collect variable solid waste management charges, based on the quantities being disposed per household and establishments. Variable rates can be fixed for pre-defined ranges of waste quantities, progressively increasing with waste generation rates. This would also imply that the ULB has the resources to record waste generation quantities. This system will function successfully only if the progressively increasing tariff is restrictive enough to prevent waste generation.

## 2.1.5 DEVELOPING A WASTE MINIMISATION PROGRAMME IN URBAN LOCAL BODIES

Waste minimisation programmes should be spearheaded by ULBs, not only to ascertain a cohesive and coordinated approach, but also to ensure that the requisite backward linkages (e.g., segregated collection of recyclables) and forward linkages (e.g., market linkages for recycling and reuse) are developed along the material supply chain to support re-processing of material, which would otherwise enter the municipal waste stream. Recycling industries, EPR initiatives, and various other initiatives including local businesses are critical to the success of these programmes. Planning for waste minimisation programmes should be a part of the overall municipal solid waste management (MSWM) planning process as described in detail in Section 1.2 of Part II. The typical process for developing a waste minimisation programme (Figure 2.2) requires the ULBs to do the following:

Figure 2.2: Developing a Waste Minimisation Programme<sup>5</sup>

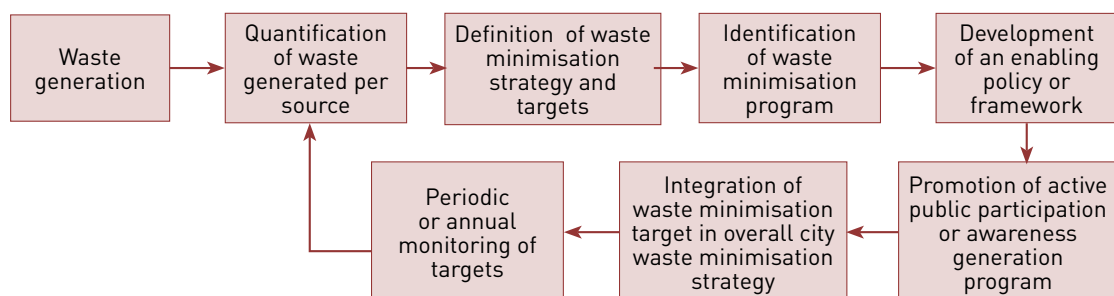

5 Developed by the Expert Committee for revision of MSWM manual (2013-15)

- Identify and quantify main contributors to the waste problem. Local waste information data system is required.
- Define sectoral waste minimisation potentials and targets (residential waste, organic market waste, institutional waste, MSW from business establishments and hospitals, etc.).
- Identification or adoption of programmes targeted at producers and generators. Programmes should be well-defined, considering viable and efficient collection and recycling systems, and supported with required municipal bye-laws to ensure implementation.
- Develop an institutional mechanism with all relevant stakeholders to facilitate implementation. Identification and registration of scrap dealers and recyclers is a pre-requisite to assess the viability and sufficiency of recycling facilities in the ULB.
- Examine environmental and health-related issues when assessing the suitability of recycling facilities in close coordination with the State Pollution Control Board (SPCB) committees.
- Assess the capacity to implement the programme and seek external expertise if required.
- Promote active awareness raising campaigns, advertising the targets, programmes, and modes of involvement of stakeholders. Targeting school children and women groups and actively engaging with the business community are essential.
- Integrating waste minimisation targets in the overall waste management strategy of the city.
- Monitor periodically the midterm targets and ensure an annual review of targets and achievements. Review stakeholder responsibilities and strengthen institutional arrangements.

### 2.1.6 ENSURING FEASIBILITY OF WASTE MINIMISATION PROGRAMMES

Waste minimisation programmes should always be supported by expertise (either in-house or contractual), institutional mechanisms, market linkages, access to robust recycling technologies, as well as regulatory and penal provisions, if needed. Actively involving all stakeholders right from the target setting and planning process is a prerequisite for implementing waste minimisation initiatives. Involvement of the state government to pass certain ordinances may also be required, depending on the nature of the programme. A strong local leadership, like the ward councillor or a local champion, is usually the driving force behind the success of such initiatives.



For a successful waste minimisation programme, technical expertise, institutional mechanisms, market linkages and regulatory and penal provisions are pre-requisites

## 2.2 SOURCE SEGREGATION

The SWM Rules, 2016 defines segregation as sorting and separate storage of various components of solid waste namely biodegradable wastes including agriculture and dairy waste, non biodegradable wastes including recyclable waste, non- recyclable combustible waste, sanitary waste and non recyclable inert waste, domestic hazardous wastes, and construction and demolition wastes.

Segregating waste at source ensures that waste is less contaminated and can be collected and transported for further processing. Segregation of waste also optimises waste processing and treatment technologies. It results in high proportion of segregated material that could be reused and recycled, leading to less consumption of virgin material. Indirectly, source segregation also impacts climate change and has many other advantages which are discussed in the section below.

### 2.2.1 SOLID WASTE MANAGEMENT RULES, 2016 - REQUIREMENTS ON SOURCE SEGREGATION

As per the SWM Rules, 2016:



Clause 4 Duties of waste generators:-

- (1) Every waste generator shall-
  - (a) segregate and store the waste generated by them in three separate streams namely bio-degradable, non bio- degradable and domestic hazardous wastes in suitable bins and handover segregated wastes to authorised waste pickers or waste collectors as per the direction or notification by the local authorities from time to time;
  - (b) wrap securely the used sanitary waste like diapers, sanitary pads etc., in the pouches provided by the manufacturers or brand owners of these products or in a suitable wrapping material as instructed by the local authorities and shall place the same in the bin meant for dry waste or non- bio-degradable waste;
  - (c) store separately construction and demolition waste, as and when generated, in his own premises and shall dispose off as per the Construction and Demolition Waste Management Rules, 2016; and
  - (d) store horticulture waste and garden waste generated from his premises separately in his own premises and dispose of as per the directions of the local body from time to time.

#### BASIC waste segregation:

- Wet waste (kitchen waste)
- Dry waste (recyclables)
- Domestic hazardous waste

- (2) No waste generator shall throw, burn or burry the solid waste generated by him, on streets, open public spaces outside his premises or in the drain or water bodies.
- (3) All waste generators shall pay such user fee for solid waste management, as specified in the bye-laws of the local bodies.
- (4) No person shall organise an event or gathering of more than one hundred persons at any unlicensed place without intimating the local body, at least three working days in advance and such person or the organiser of such event shall ensure segregation of waste at source and handing over of segregated waste to waste collector or agency as specified by the local body.
- (5) Every street vendor shall keep suitable containers for storage of waste generated during the course of his activity such as food waste, disposable plates, cups, cans, wrappers, coconut shells, leftover food, vegetables, fruits, etc., and shall deposit such waste at waste storage depot or container or vehicle as notified by the local body.
- (6) All resident welfare and market associations shall, within one year from the date of notification of these rules and in partnership with the local body ensure segregation of waste at source by the generators as prescribed in these rules, facilitate collection of segregated waste in separate streams, handover recyclable material to either the authorised waste pickers or the authorised recyclers. The bio-degradable waste shall be processed, treated and disposed off through composting or biomethanation within the premises as far as possible. The residual waste shall be given to the waste collectors or agency as directed by the local body.
- (7) All gated communities and institutions with more than 5,000 sqm area shall, within one year from the date of notification of these rules and in partnership with the local body, ensure segregation of waste at source by the generators as prescribed in these rules, facilitate collection of segregated waste in separate streams, handover recyclable material to either the authorised waste pickers or the authorized recyclers. The bio-degradable waste shall be processed, treated and disposed off through composting or biomethanation within the premises as far as possible. The residual waste shall be given to the waste collectors or agency as directed by the local body.
- (8) All hotels and restaurants shall, within one year from the date of notification of these rules and in partnership with the local body ensure segregation of waste at source as prescribed in these rules, facilitate collection of segregated waste in separate streams, handover recyclable material to either the authorised waste pickers or the authorised recyclers. The bio-degradable waste shall be processed, treated and disposed off through composting or biomethanation within the premises as far as possible. The residual waste shall be given to the waste collectors or agency as directed by the local body.



### Clause 15 Duties and responsibilities of local authorities:-

- (b) arrange for door to door collection of segregated solid waste from all households including slums and informal settlements, commercial, institutional and other non residential premises. From multi-storage buildings, large commercial complexes, malls, housing complexes, etc., this may be collected from the entry gate or any other designated location;
- (g) direct waste generators not to litter i.e throw or dispose of any waste such as paper, water bottles, liquor bottles, soft drink cans, tetra packs, fruit peel, wrappers, etc., or burn or burry waste on streets, open public spaces, drains, waste bodies and to segregate the waste at source as prescribed under these rules and hand over the segregated waste to authorised the waste pickers or waste collectors authorised by the local body;
- (h) setup material recovery facilities or secondary storage facilities with sufficient space for sorting of recyclable materials to enable informal or authorised waste pickers and waste collectors to separate recyclables from the waste and provide easy access to waste pickers and recyclers for collection of segregated recyclable waste such as paper, plastic, metal, glass, textile from the source of generation or from material recovery facilities; Bins for storage of bio-degradable wastes shall be painted green, those for storage of recyclable wastes shall be printed white and those for storage of other wastes shall be printed black;
- (i) establish waste deposition centres for domestic hazardous waste and give direction for waste generators to deposit domestic hazardous wastes at this centre for its safe disposal. Such facility shall be established in a city or town in a manner that one centre is set up for the area of twenty square kilometers or part thereof and notify the timings of receiving domestic hazardous waste at such centres;
- (k) direct street sweepers not to burn tree leaves collected from street sweeping and store them separately and handover to the waste collectors or agency authorised by local body;
- (m) collect waste from vegetable, fruit, flower, meat, poultry and fish market on day to day basis and promote setting up of decentralised compost plant or biomethanation plant at suitable locations in the markets or in the vicinity of markets ensuring hygienic conditions;
- (n) collect separately waste from sweeping of streets, lanes and by-lanes daily, or on alternate days or twice a week depending on the density of population, commercial activity and local situation;
- (p) collect horticulture, parks and garden waste separately and process in the parks and gardens, as far as possible;



- (ze) ensure that provisions for setting up of centers for collection, segregation and storage of segregated wastes, are incorporated in building plan while granting approval of building plan of a group housing society or market complex; and



#### Clause 15 1(2.b) Storage of segregated solid waste at source:-

- (zg) create public awareness through information, education and communication campaign and educate the waste generators on the following; namely:-
  - (iv) practice segregation of waste into bio-degradable, non-biodegradable (recyclable and combustible), sanitary waste and domestic hazardous wastes at source;
  - (vi) wrap securely used sanitary waste as and when generated in the pouches provided by the brand owners or a suitable wrapping as prescribed by the local body and place the same in the bin meant for non- biodegradable waste;
  - (vii) storage of segregated waste at source in different bins;
  - (viii) handover segregated waste to waste pickers, waste collectors, recyclers or waste collection agencies;

ULBs should ensure that source segregated waste is collected and also transported separately

### 2.2.1.1 SEGREGATION OF MUNICIPAL SOLID WASTE AT SOURCE

As directed by SWM Rules, 2016:



#### Clause 4 1) Duties of waste generators-every waste generator shall:-

- a) segregate and store the waste generated by them in three separate streams namely bio-degradable, non -biodegradable and domestic hazardous wastes in suitable bins and handover segregated wastes to authorised waste pickers or waste collectors as per the direction or notification by the local authorities from time to time;
- b) wrap securely the used sanitary waste like diapers, sanitary pads etc., in the pouches provided by the manufacturers or brand owners of these products or in a suitable wrapping material as instructed by the local authorities and shall place the same in the bin meant for dry waste or non- bio-degradable waste.

After achieving BASIC segregation, ULBs should aim to move toward BASIC+ segregation



#### Clause 15 Duties and responsibilities of local authorities:-

- i) establish waste deposition centres for domestic hazardous waste and give direction for waste generators to deposit domestic hazardous wastes at this centre for its safe disposal. Such facility shall be established in a city or town in a manner that one centre is set up for the area of twenty square kilometers or part thereof and notify the timings of receiving domestic hazardous waste at such centres.



### Clause 17 Duty of manufacturers or brand owners of disposal products and sanitary pads and diapers:-

- (3) Manufacturers or brand owners or marketing companies of sanitary napkins and diapers shall explore the possibility of using all recyclable materials in their products or they shall provide a pouch or wrapper for disposal of each napkin or diapers along with the packet of their sanitary products.
- (4) All such manufacturers, brand owners or marketing companies shall educate the masses for wrapping and disposal of their products.

As per biomedical rules, 2016, biomedical waste generated in households during healthcare activities shall be segregated as per these rules and handed over in separate bags or containers to municipal waste collectors. Urban Local Bodies shall have tie up with the common biomedical waste treatment and disposal facility to pickup this waste from the Material recovery facility (MRF) or from the house hold directly, for final disposal in the manner as prescribed in Schedule I part 2 of the Biomedical Waste Rules, 2016.

Waste should be stored at the source of waste generation until it is collected for disposal by ULB staff or appointed contractors. It is essential to segregate wastes into wet (kitchen waste); dry (recyclables and other waste); and domestic hazardous waste (CFL, tube light, etc.). This is commonly referred to as BASIC segregation. Segregation of MSW needs to be linked to primary collection of waste from the doorstep and given high priority by the ULBs. Unless door-to-door collection of segregated waste and transportation of segregated waste is practiced by the ULBs, source segregation by waste generators will not be successful and remain a meaningless exercise.

The local community should be educated and encouraged to perform the following actions to ensure collection of segregated waste:

- At the household level, MSW should be segregated into wet, dry, and domestic hazardous waste fractions, at a minimum, and stored in separate containers.
- Waste should be placed at the doorstep before the appointed time of collection.
- Domestic hazardous waste (e.g., batteries; used CFLs; tube lights; chemical, paint, and insecticide containers; etc.) should be handed over separately to the waste collectors or at the domestic hazardous waste deposition centers for safe disposal as specified by the municipal authority or through the relevant retail trade (e.g., for batteries).

- Sanitary waste (e.g., diapers, sanitary napkins, tampons, incontinence sheets and any other similar waste) should be wrapped securely in the pouches and handed over separately to the waste collectors on a daily basis. Upon collection of sanitary waste, it should be preferably disposed in biomedical or MSW incinerators, as applicable to the local context or as directed by the SPCB.
- However, for efficient collection and disposal of sanitary waste, it should be wrapped in the pouch provided by the manufacturer and put in separate bags and handed over separately on daily basis to the waste collector in order to minimise the manual handling of sanitary waste. Once collected separately, it should be sent either directly to the biomedical waste incineration facility or to Material Recovery Facility (MRF) for collection and then sending to the biomedical waste incinerator when sufficient quantities are collected, as per the arrangement of the city.



**The Bruhat Bangalore Mahanagara Palike (BBMP)** has set up domestic sanitary waste collection centres in 22 wards, where citizens may deliver such waste marked with a red cross to enable further segregation in addition to other dry recyclable waste. The collected waste is then sent for disposal in municipal sanitary landfills or biomedical or MSW incinerators.

**Corporation of Panaji** collects the sanitary waste in yellow plastic bags, separately and on a daily basis and sends them to the material recovery facility. When sanitary waste is collected in sufficient volumes at the material recovery facility, it is sent to the biomedical waste incinerator at the Goa Medical College.



#### **Duties of Municipal Authorities:**

1. Ensure primary and secondary collection and transportation of segregated waste streams consisting of at least three fractions (wet, dry, and domestic hazardous wastes). These wastes should not be mixed during collection and transportation.
2. Segregate wastes further (BASIC+segregation) once three-bin segregation is achieved (Table 2.1).
3. Establish collection systems (e.g., community pick-up points or delivery systems through the retail trade) for domestic hazardous waste and special waste. Wastes may be collected from these facilities once in 15 days or as found appropriate by the ULB.
4. Ensure that domestic hazardous waste and special waste are handled as directed by the State Pollution Control Board or committees.

**Table 2.1: Indicative List for Segregation of Household Wastes<sup>6</sup>**

| BASIC SEGREGATION  |                                     |  |   |  |   |
|--|-------------------------------------|--|---|--|---|
| Wet waste (green bin)  | Dry waste (Blue bin)                |  |   |  | Domestic Hazardous <sup>7</sup>   |
|  | With further sub-segregation BASIC+ |  |   |  |   |
| Food wastes of all kinds, cooked and uncooked, including eggshells and bones, flower, fruit and waste including juice, vegetable peels and household garden/plant wastes. Soiled tissues, food wrappers, paper towels; fish and meat   | Paper cardboard and cartons         | Containers & packaging of all kinds excluding those containing hazardous materials Compound packaging (tetrapak, blisters etc.) Plastics | Rags<br>Rubber<br>Wood<br>Discarded clothing<br>Furniture | Metals<br>Glass (all kinds)<br>Inerts<br>House sweepings and inerts (not garden, yard or street sweepings) | E-waste*<br>Hazardous wastes**<br>Household medical waste***<br>Batteries from flashlights and button cells.<br>Lights bulbs, tube lights and Compact Fluorescent Lamps (CFL)<br>Car batteries, oil filters and car care products and consumables |
| <p>* E-waste: Printer &amp; printer cartridges, electronic parts and equipment and others</p> <p>** Hazardous wastes: Chemicals and solvents and their empty containers, paints, oil, lubricants, glues, thinners and their empty containers, insecticides, pesticides and herbicides and their empty containers, photographic chemicals, bleaches and household kitchen &amp; drain cleaning agents</p> <p>*** Household Medical Waste: Thermometers and other mercury containing products, discarded medicines, injection needles and syringes after destroying them both, sanitary wastes and diapers (should be collected daily)</p> |                                     |  |   |  |   |

<sup>6</sup> Adapted from Manual on Municipal Solid Waste Management (First Edition), Central Public Health and Environmental Engineering Organisation (CPHEEO), 2000, Ministry of Urban Development.

<sup>7</sup> To be stored and disposed separately.



## A Journey Towards a Successful Waste Management System Leading to a Landfill-less City

**Location:** Panaji

**Year of Start:** 2003

**Main Players:** Corporation of the City of Panaji (CCP), school and college staff and students, resident welfare associations (RWAs), local leaders and celebrities

**Approach:** Panaji, the capital of Goa, is a city with a strong cultural heritage. Apart from being a popular tourist destination, it is also an administrative centre and commercial hub for the state. Under the strong political will and administrative leadership of the Municipal Commissioner, a comprehensive city revitalisation campaign was launched to improve sanitary conditions and solid waste management (SWM). The “Bin Free in 2003” campaign was part of the “Together for Panjim” initiative. Under this initiative, the following strategies were adopted to significantly improve the SWM system.

### Technical Strategy:

- Community bins were substituted by trolley bins as an intermediate stage of transfer.
- Modifications were made in the hydraulic arm of the garbage trucks to enable transfer of waste from the trolley bin into the truck without manual intervention.
- Segregation at source was initially introduced as wet and dry segregation (two bins). As of 2015, source segregation is undertaken in eight clear waste streams (wet, paper, plastic bags, metals or glass, non-recyclable, tetrapacks, cardboard, and plastic bottles) with designated colour coding for the waste fractions.
- Household bins with screw on lids were designed to prevent spillage of garbage by stray animals when households keep waste outside for collection.
- Material recycling stations were established within colonies for further segregation of dry waste.
- Decentralised composting units were constructed for converting wet waste into manure for community usage. Hotels were also asked to install decentralised composting units in their premises.
- Tie-ups were made with various recycling units for selling bulk segregated wastes.
- Extended producer responsibility (EPR) initiatives were adopted through innovative measures like
  - tie-ups with local dairies for paying residents a specified amount for returning washed empty plastic milk bags at the local dairy booths; and
  - tie-up with Tetra Pak (company) for buyback of empty tetrapacks.
- Co-processing of plastics and other dry fraction rejects in the cement industry:
- Two baling machines (1 ft x 1 ft and 1 m x 1 m) for bailing dry fractions or plastic waste for different cement plants were designed. Bailed waste was sent to four different cement plants, 250 km–600 km from the CCP, for co-processing.
- Hazardous wastes like batteries and tube lights were segregated and, once sufficient quantities were obtained, transported to the treatment, storage, and disposal facility (TSDF) in Karnataka.



Segregation of dry waste into 8 streams



Composting units in housing societies

- E-waste and thermocol were collected separately, but currently no tie-ups exist between them.

#### **Institutional Strategy:**

- A SWM cell was formed in the CCP, headed by a Waste Management Officer.
- The field services were headed by a Sanitary Inspector who was in charge of 15 supervisors to oversee the waste collection and transportation of each zone.
- Intensive monitoring was carried out by the corporation staff.
- Centralised complaint redressal system was established with a 24-hour helpline to clear any uncollected or unattended garbage. Quick response vehicle was designated for the purpose.
- Adequate health and safety measures were provided to the sanitary workers.

#### **Public Communication Strategy:**

- To initiate the segregation process at the household level, green and black bins were provided to the residents at subsidised rates.



Segregated transport

- For increasing community participation in this drive, the Municipal Commissioner and the Waste Management Officer organised meetings to disseminate the details of

the management system, its functioning, and the segregation of waste at household level.

- As part of the campaign, cultural programmes like music festivals, fairs, and carnivals were held with a theme and message of civic hygiene and responsibilities of citizens toward maintaining cleanliness in the city.
- Involvement of schools and colleges in the campaigns were promoted.
- Waste management was introduced to children from primary school onward, and children learned the different colour codes for segregation in school.

#### **Financial Strategy:**

- User charges were introduced by the CCP and collected by the supervisors. Maintaining the ward-wise accounts, the supervisors were responsible for payment of cash incentives to the collection and transportation workers and for depositing the surplus amount.
- Other revenue sources were
  - sale of compost;
  - sale of segregated waste for recycling like plastic bottles, cardboard boxes, etc.; and
- EPR initiatives, e.g., with Tetra Pak.
- Costs were incurred by the CCP for bailing and transporting waste for co-processing to cement plants. This acted as an incentive for increasing recycling tie-ups with other players in the market.

#### **Outcome:**

- Collection of segregated waste from the households was 100%, and waste was further sorted into eight waste streams at the recycling stations.
- Ragpickers, women volunteers, and self-help groups (SHGs) were actively involved in streamlining the waste management system.
- Segregated waste was transported to the recycling units and compost units for further processing.
- Recycling efficiency improved through market creation and tie-ups for PET bottles, plastic bags, etc.
- Waste to landfill was minimised through effective management by co-processing waste fractions and sending hazardous waste to TSDF.

#### **Success Factors:**

- The vision for the city was clear, and there was a strong and stable leadership.
- Institutional and managerial models were established within the CCP.
- Technical innovations were designed for segregation, minimal manual handling of waste, co-processing, EPR, and tie-ups.
- Intensive campaigning and meetings with RWAs on the overall concept of source segregation were promoted. Youth, local celebrities, corporation staff, and communities were actively involved in awareness generation activities. The waste segregation system was integrated in the curricula from primary level onward.

### Overall Sustainability:

The expenditure on the solid waste programme has been managed entirely from the CCP's own sources. Collection of user charges and the various recycling initiatives have resulted in the financial sustainability of the project. The cash incentive scheme for the workers has ensured the programme is running on the ground. And surplus fund is deposited into the CCP's account for later use or innovation.

*Source: CCP*



### Source Segregation of Municipal Solid Waste and its Institutionalisation at Kochi

**Year of Start:** 2007

**Main Players:** Corporation of Cochin (CoC), resident welfare associations (RWAs), ward committees, Kudumbashree, Confederation of Real Estate Developers' Associations of India (CREDAI), Rotary Club of Cochin, and other community-based organisations (CBOs) and non-government organisations (NGOs)

**Approach:** In 2002, the CoC, based on an earlier pilot initiative, decided to scale up source waste segregation and door-to-door collection initiatives as part of an integral solid waste management (SWM) strategy. The CoC initiated a citywide process of source segregation at the ground level as a joint initiative with community representatives, Kudumbashree, RWAs, NGOs, and CREDAI. To achieve source segregation, the following integrated approaches were adopted—institutional; managerial; legal; financial; and information, education, and communication (IEC) initiatives or improvements.

#### Institutional:

- Ward-level sanitation committees were formed with the respective Ward Councilor as Chairman; Junior Health Inspector; and the representatives of RWAs, Kudumbashree, CREDAI, NGOs, etc. as members for each ward.
- Health and safety measures were provided partially to the sanitation workers.
- CoC provided two different color bins free to all households—green (wet waste) bin of 15 liter (l) capacity and white (dry waste) bin of 10 l capacity.
- CoC provided three wheeler cycles or pushcarts and auto rickshaws to the wards for door-to-door collection.
- CoC provided trucks and regular workers for onward transporting of MSW at the ward level collection.

#### Managerial:

- Out of 74 wards, 15 wards were served by Kudumbashree (self-help groups [SHGs] of women) and the remaining 59 wards by contracted workers of the RWAs, NGOs, and CREDAI (serving in high-rise apartments registered under CREDAI).
- CoC's regular sanitary workers were also involved.

#### Legal:

- CoC passed bye-laws in 2008 to make segregation mandatory and a stringent penal



provision in case households did not provide segregated waste to the waste collectors.

- Initially, a patrolling system was designed to monitor illegal dumping, collection, and transportation of waste. The monitoring was done in shifts, and a spot fine of Rs250–Rs10,000 was charged, depending on the quantity and quality of waste found during illegal dumping.
- CoC also levied fines on transportation contractors for not transporting segregated waste from households(HHs).

#### **Financial:**

- CoC introduced user charges of Rs30–Rs80 per household and Rs100–Rs200 per commercial establishment.

#### **Information, Education, and Communication:**

- Members of the ward-level sanitation committees organised the meetings with residents and interacted with communities regarding the concept and importance of segregation.
- Simultaneously, under IEC and awareness generation activities among citizens, CoC published various brochures and pamphlets and involved print and electronic media for disseminating information on segregation at household level.

#### **Outcome:**

- Collection of segregated waste (wet and dry) from households was 80%.
- The collection system as developed by RWAs, ward-level committees, Kudumbashree, and CREDAI integrated ragpickers on contractual basis as waste collectors.
- Door-to-door collection and source segregation ultimately led to a bin-free city and reduced the amount of waste to landfill.
- Segregated waste was transported to the processing plant.

#### **Success Factors:**

- Institutional and managerial models were established.
- Intensive interactive meetings on the overall concept of segregation with residents and citizens of wards were held by the ward council, corporation officials, councilors, and the representatives of NGOs and sanitation committees.
- Effective community participation to adapt to the new system was ensured.
- Communication tools were developed and disseminated regularly to the communities.
- Educational institutions, NGOs, and local celebrities were actively involved in awareness generation activities.

#### **Overall Sustainability:**

It is a self-sustainable working model with no direct financial involvement in the municipal budget except for provision of physical infrastructure like handcarts and operation and maintenance (O&M) of transportation system. The collection system is completely managed by the RWAs, CREDAI, and Kudumbashree. User charges are collected directly by the door-to-door waste collectors and are used for funding the salary of the workers. The collection and segregation system in Kochi has been self-sustaining since its inception in 2007.

*Source: CoC*

## 2.2.1.2 STORAGE OF MUNICIPAL SOLID WASTE AT SOURCE

### 2.2.1.2.1 Household-level Storage of Segregated Waste

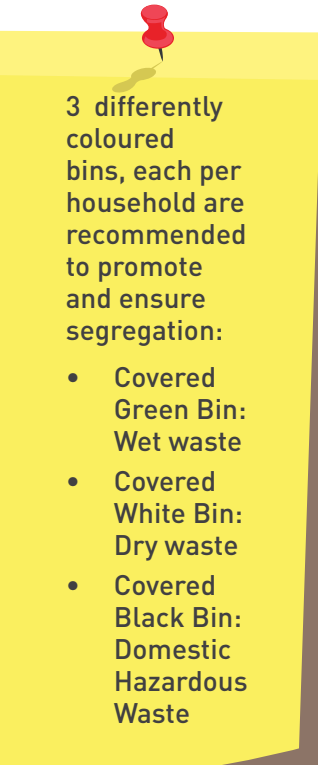

3 differently coloured bins, each per household are recommended to promote and ensure segregation:

- Covered Green Bin: Wet waste
- Covered White Bin: Dry waste
- Covered Black Bin: Domestic Hazardous Waste

At the household level, dry waste, wet waste, and domestic hazardous waste should be stored in separate garbage bins, of appropriate capacity and colour (Figure 2.3). The colour of the garbage bins should be in accordance with the SWM Rules, 2016; wet waste is to be placed in a covered green bin and dry waste in a covered white bin. Because the rule does not specify the colour of the bins for storage of domestic hazardous waste, urban local bodies (ULBs) should decide on an appropriately coloured bin. For example, Coimbatore City Municipal Corporation uses red bins for collection of domestic hazardous waste. Capacity of bins depends on frequency of collection (daily, alternate day, or on demand) and quantity of waste generated.

A container of 12–15l (0.015 m<sup>3</sup>) capacity for a family of five members should be adequate for each dry and wet waste, if collection takes place daily. However, a household may keep larger containers or more than one container for waste produced in 24 hours, having a spare capacity of 100% to meet unforeseen delays in clearance or unforeseen extra loads. If dry waste is not collected daily, container capacity has to be enlarged accordingly. Wet waste collection bins should be washed by the household each time they are emptied. It is not desirable to use plastic bags in waste bins.

In large apartment complexes and multistoried buildings, gated communities large waste collection bins for wet waste and dry waste should be placed at a convenient location. Residents should deposit segregated waste in the respective bins either themselves or through organised door-to-door collection system of the resident welfare association (RWA) or community-based organisation (CBO). Specification of bins and containers shall be compatible with primary collection vehicles, if applicable.

Typical specifications for garbage bins used in apartment complexes and large buildings are the following: 60l (25kg) bins suitable for 12 households, 120l (50kg) bins for 24 households, 240l (96 kg) bins for 48 households, etc. that are of standard quality, high-density polyethylene (HDPE), injection or roto molded, ultraviolet (UV) tested, durable and could withstand rough handling, and compatible with lifting mechanism on primary collection vehicle, if applicable. The specific size of the containers depends on the number of connected households and the frequency of collection.

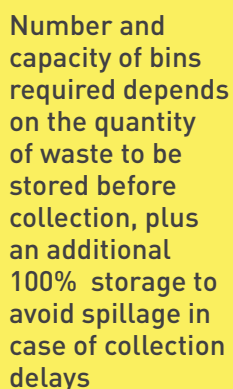

Number and capacity of bins required depends on the quantity of waste to be stored before collection, plus an additional 100% storage to avoid spillage in case of collection delays

**Figure 2.3: Bins for Collection of Dry, Wet and Domestic Hazardous Waste at Household<sup>8</sup>**



### 2.2.1.2.2 On-site Storage of Bulk Wastes

“Bulk Waste Generator” means and includes buildings occupied by the Central government departments or undertakings, State government departments or undertakings, local bodies, public sector undertakings or private companies, hospitals, nursing homes, schools, colleges, universities, other educational institutions, hostels, hotels, commercial establishments, markets, places of worship, stadia and sports complexes having an average waste generation rate exceeding 100kg per day; the ULB may define the per day quantum of waste per generator that would classify as bulk waste. Shops, commercial establishments, and businesses should store segregated waste on-site. Whereas vegetable and flower market waste generators should deposit their waste in conveniently located large green bins for preferable utilization of waste on site or as directed by ULB. Number and capacity of bins required may be computed by considering quantity of waste to be stored before collection plus an additional 100% storage. Storage bins should be compatible with the primary collection system to avoid multiple handling of waste.

Typically, four-wheeled, HDPE, injection or roto molded, international standard, UV tested bins or metal bins of different capacities—e.g., for 240 l (96 kg), 600 l (270–280 kg), 770 l (315–350 kg), 1,100 l (449–495 kg)—may be used for bulk waste. These bins should be compatible with auto lifting by standard universal bin lifting devices on mobile compactors and other vehicles.

Bins should be compatible with the collection system to avoid multiple handling

8 “Panjim’s Initiatives in Solid Waste Management”, Rodrigues, S. (2013). Available at:[http://iipnetwork.org/Rodriguez\\_Towards-Green-Trash](http://iipnetwork.org/Rodriguez_Towards-Green-Trash)

For specific storage requirements for construction and demolition (C&D) waste, please refer to Section 3.7 of Part II. Small quantities of C&D waste are to be stored separately at household level, and this waste is to be transferred to the community C&D waste collection bins.

### 2.2.1.2.3 Storage of Municipal Solid Waste in Public Places or Parks

With a view to ensure that streets and public places are not littered with waste, litter bins (Figure 2.4) may be provided at important streets, markets, public places, tourist spots, bus and railway stations, large commercial complexes, etc. at a distance ranging from 25m to 250m depending on the local conditions. The collection from these bins should be segregated into wet and dry waste.

Figure 2.4: Typical Waste Collection Bins in Parks and along Walk-Ways<sup>9</sup>



Adequate number of bins at optimum distance (25–250 m) should be placed at public places to avoid littering

### 2.2.1.3 STORAGE OF YARD WASTE OR GARDEN WASTE

The SWM Rules, 2016 suggests that horticulture waste from parks and gardens should be collected separately and treated on-site to make optimum use of such wastes and also to minimise the cost of its collection and transportation. In large cities, the municipal authority may provide large containers for storage of waste or facilitate provision of large containers through private sector participation. In small cities, such waste may be stored on-site and the municipal authority may facilitate its periodic collection, either through the SWM department or by involving the private sector. The skip bins or containers shall be of a standard design and amenable to automatic hydraulic lifting and unloading by a transport vehicle. This waste should not be mixed with domestic waste.

On site composting of yard waste/ green waste should be promoted

9 Indiamart. Road Side Twin Litter Bins Available at: <http://trade.indiamart.com/details.mp?offer=1761050930>

## 2.2.1.4 STORAGE AND PROCESSING OF SPECIAL WASTES INCLUDING DOMESTIC HAZARDOUS WASTE

Special wastes including domestic hazardous wastes are generated by residential, commercial, or institutional facilities which are regulated by rules other than the SWM Rules, 2016 and consist of the fractions mentioned in Table 2.1.

Special wastes including domestic hazardous wastes can pose a substantial or potential threat to health and environment because of their constituents which may be hazardous. A municipal waste component is hazardous if it contains one of the following characteristics: (i) ignitability, (ii) corrosivity, (iii) reactivity, and (iv) toxicity.



### Special Wastes including Domestic Hazardous Wastes Categories from Households

- Printer cartridges, electronic parts and equipment
- Batteries from flashlights and button cells
- Bleaches and household kitchen & drain cleaning agents
- Car batteries, oil filters and car care products, consumables
- Chemicals and solvents and their empty containers
- Insecticides, pesticides and herbicides and their empty containers
- Light bulbs, tube-lights and compact fluorescent lamps (CFL)
- Paints, oils, lubricants, glues, thinners, and their empty containers
- Photographic chemicals
- Thermometers and other mercury containing products
- Discarded medicines, injection needles and syringes, after destroying them



Clause 15(j) of SWM Rules, 2016 ensure safe storage and transportation of the domestic hazardous waste to the hazardous waste disposal facility or as may be directed by the State Pollution Control Board or the Pollution Control Committee.

All waste generators should be directed by the municipal authority to not mix special waste including domestic hazardous waste with either the wet waste or dry waste, but to store such wastes separately and hand-over to the special waste collection centres, which should be established by the urban local bodies or to collection schemes through retail trade. The Rules have further directed ULBs to establish one domestic hazardous deposition/delivery centre per 20 sq. km.



Clause 15(i) of SWM Rules, 2016 establish waste deposition centres for domestic hazardous waste and give direction for waste generators to deposit domestic hazardous wastes at this centre for its safe disposal. Such facility shall be established in a city or town in a manner that one

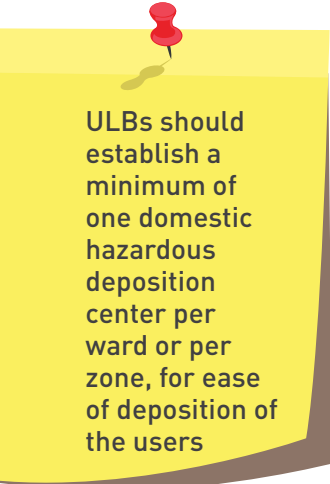

ULBs should establish a minimum of one domestic hazardous deposition center per ward or per zone, for ease of deposition of the users

centre is set up for the area of twenty square kilometers or part thereof and notify the timings of receiving domestic hazardous waste at such centres;

However, given that ULBs are of varying sizes, larger ULBs may decide to establish one domestic hazardous deposition site per ward; smaller ULBs may choose to place the deposition centre(s) at appropriate locations, such as market places and commercial areas. The timings for receiving domestic hazardous waste at such centre should be notified to public, while ULBs should ensure safe handling of such waste as may be directed by the SPCB or PCC from time to time. ULBs should establish a minimum of one domestic hazardous deposition centre per ward or per zone, for ease of deposition of the users.

Manufacturers and suppliers of products resulting in special wastes should be encouraged to develop systems for “take back”, treat or recycle such wastes, or send wastes to registered recyclers, as appropriate.

Having hazardous components, MSW has to be distinguished from hazardous wastes generated by commercial and industrial units, as defined by the Hazardous and Other Wastes (Management and Transboundary Movement) Rules, 2016. Hazardous wastes should be disposed by the generating unit at the nearest treatment, storage, and disposal facility (TSDF). ULBs can also hold other hazardous waste manufacturers accountable, under aforesaid rules. E-waste shall be segregated at source and shall not be mixed with MSW. Special wastes are covered in detail in Section 7 of Part II.

#### **2.2.1.5 MANAGING INDUSTRIAL WASTES GENERATED WITHIN MUNICIPAL JURISDICTIONS (EXCLUDING INDUSTRIAL ESTATES WITHIN MUNICIPAL AREAS)**



SWM Rules, 2016 are also applicable to industrial townships, areas under the control of Indian Railways, airports, airbases, Ports and harbours, defence establishments, special economic zones, State and Central government organisations, places of pilgrims, religious and historical importance as may be notified by respective State government from time to time and to every domestic, institutional, commercial and any other non residential solid waste generator situated in the areas except industrial waste, hazardous waste, hazardous chemicals, bio medical wastes, e-waste, lead acid batteries and radio-active waste, that are covered under separate rules framed under the Environment (Protection) Act, 1986.

Industrial solid waste refers to waste generated by processing activities of different industries, e.g., thermal power plants producing coal ash; integrated iron and steel mills producing blast furnace slag and steel melting slag; nonferrous industries like aluminium, zinc, and copper producing red mud and tailings; etc. Industrial waste can be solid, liquid, or gas, and can be hazardous or non-hazardous. Hazardous industrial waste may cause

danger to public health and environment and hence should not be mixed with MSW. Large industries have to manage their waste by themselves and are required to seek authorisations from respective SPCBs.

Small-scale service industries (both registered and unregistered) within city limits—e.g., automobile garages, electroplating industry, dyeing industry, lathe machines, etc.—which generate hazardous waste, should be identified by the ULB through a primary survey. A clear-cut plan for management of wastes from these industries should be chalked out for its separate collection, transportation, and appropriate disposal in consultation with the SPCB or PCC.

Although ULBs are not responsible for the management of industrial solid waste, ULBs should ensure that MSW generated by the industrial units should be handled appropriately by the industry. In places where the industrial unit or area has no appropriate municipal solid waste management (MSWM) system, a tie up with the regular MSWM system of the ULB should be organised. Collection of MSW from such units should be closely monitored to ensure that there is no cross contamination of waste with industrial waste illegally dumped in the municipal bins.

## 2.2.2 PUBLIC PARTICIPATION AND AWARENESS

The SWM Rules, 2016 direct ULBs to create public awareness through information, education, and communication (IEC) campaigns and educate the waste generators to minimise waste and prohibit littering. Municipal authorities should organise awareness generation programmes promoting segregation of waste and recycling or reuse of segregated waste. The communities should be educated, informed, and trained on waste segregation. ULBs should sensitise citizens to associated environment and health hazards of improper waste management. Further, the citizens should be made aware of the need to pay user fees or charges for ensuring sustainability of the MSWM services.

This process is most effective when led by the Mayor or Chairperson and the Chief Executive of the ULB, and prominent people are involved in the campaign to motivate the society at large. To ensure segregation at household level, along with the proper system of door-to-door collection and transportation, there must be sustained efforts by the authorities and strong leadership to motivate the citizens over a period of 15 days to one month along with the proper system (e.g., case study on Warangal).

Involvement of RWAs, CBOs, NGOs, self-help groups (SHGs), and market associations is imperative to ensure the success of segregation at source. Regular meetings among the ULB staff and representatives



Post the introduction campaigns, regular reinforcements of segregation concepts will ensure full adoption by community



Building community awareness and consensus is essential for ensuring community participation in storage of segregated waste

of RWAs, market associations, NGOs, SHGs, and other stakeholders should be held until the community fully adopts this practice.

The ULB through the NGOs, Rotary clubs, CBOs, and other such organisations should conduct school-level awareness and education programmes focusing on source segregation; waste minimisation through reduce, reuse, and recycle; and the importance of proper management of waste. Students should be made aware of the menace posed by increasing waste quantities and environmental impacts of unscientific disposal. School authorities should educate and encourage students to practise segregation of waste in schools as per specifications given above in Table 2.1.



### **The Clean Cities Championship: A Participatory Approach for Improved Municipal Solid Waste Management in Warangal**

**Location:** Warangal

**Population:** 3,512,576 (Census, 2011)

**Year of Start:** 2012

**Main Players:** Directorate of Municipal Administration, Government of Andhra Pradesh, Warangal Municipal Corporation (WMC), Clean Cities Foundation, Andhra Pradesh Industrial & Technical Consultancy Organisation, Andhra Pradesh Pollution Control Board, communities, and school students.

**Approach:** In order to make waste management a competitive sport, the Clean Cities Foundation in partnership with the Directorate of Municipal Administration started the initiative of source segregation and door-to-door collection service in collaboration with Andhra Pradesh Pollution Control Board and Andhra Pradesh Industrial & Technical Consultancy Organisation. This was a low-cost participatory approach for integrated municipal solid waste management. The process included a hands-on approach to planning a sound waste management system and then implementing cost-effective solutions on the ground. Strong leadership from the administrators and politicians ensured participation and revenue generation for sustaining the process.

#### **The following approach was adopted:**

- Financial grants for the championship were first secured from different departments at state level.
- Intensive pre-championship activities were carried out, namely:
  - Planning inputs: Assessment of resource and capacity enhancement needs for WMC
  - Administrative planning: Creation of solid waste management (SWM) and resource management wing within WMC with clear roles and responsibility
  - Technical planning: Micro route mapping and collection and transportation efficiency route synchronisation



- Procurement of infrastructure like
  - Pushcarts with tools for segregation, bins, weighing scales, dry resource bags, and personal protective equipment
  - Tractors, sirens, and audio systems
  - Vermicompost sheds and windrow compost pads and dump site
  - Dry resource centers with bailing units
  - Biogas plant
- Transportation plan and rationalisation of vehicles, including servicing and deployment of compactors for secondary transportation
- Route and loading plans (373 pushcart-wise maps for 53 wards) prepared by field-level functionaries for the entire city on geographic information system maps provided by WMC, thus ensuring ownership of WMC
- Tie-ups with:
  - Private weighbridge close to dump site for continuous measurement of waste quantities
  - Recycling units to sustain the activity through revenue generation and creation of market for the material
  - Cement plants for dry combustibles that could not be recycled
- Stakeholder involvement:
  - Women SHGs were involved in door-to-door collection of waste in 60,000 households, which they already served. This was to demonstrate waste collection to other households in the area.
  - Mass awareness campaigns regarding segregation of waste were organised through different means like media, cycle rallies, etc. Focus group discussions among religious groups, resident welfare associations (RWAs), schools, colleges, self-help groups (SHGs), etc. were also conducted.
  - The WMC staff and municipal staff from other cities were divided into teams and received hands-on training during the championship. There were 240 teams from WMC and 130 teams from other cities.
- Training and Capacity Building:
  - Teams for carrying out the segregation and collection of waste were organised.
  - Training on the segregation and collection of waste was provided to the municipal staff and workers

### **The Championship :**

- Championship was spread over 7 days.
- Different coloured contest cards were introduced for the municipal staff, SHGs, and households during the championship. Signatures on the cards by the route monitors (National Cadet Corps) earned eligibility to be part of the target group draw for prizes.
- Intensive micro and macro level management and continuous dynamic SMS updates were made on the official website of WMC for verification.

- Each participating team (WMC and other cities) was assessed for performance, and the winning team was awarded.

**Outcome:**

- SWM wing was established to oversee the task carried out on a timely basis and to address the problems as and when generated.
- Segregated waste was collected and weighed daily per route, and the data bank was updated through internet on real-time basis. Accurate measurements were documented for the total waste generated in Warangal City and of recycled, combustible, and compostable waste.
- Segregated waste was further transported to sorting centers, recycling units, and cement plants.
- WMC was able to reduce 30% to 40% of waste going to the dump site.
- Improved collection efficiency through constant training, monitoring, and efforts from the team to build the capacities of the workers.

**Success Factors:**

- A strong political and administrative will was required, and the Commissioner led the championship.
- Strategic planning and correct pre-assessment of the existing situation were initiated.
- Minimal financial inputs were needed to improve or adopt the locally appropriate technologies for the required capacity of MSW in the city.
- Training of municipal staff and SHGs was implemented and so was the ownership of the ground level workers in the system.
- Training and capacity building of the urban local body (ULB) staff was promoted as well as awareness and involvement of the citizen to ensure continued practice of the system.
- Intensive campaigning and interaction of officials with citizens was initiated regarding the proposed door-to-door collection and segregation of waste.
- Intensive monitoring of activities by the ULB was carried out with support of different group like citizen groups, National Cadet Corps, online systems, etc.

**Sustainability:**

There has been a reduction in operation and maintenance (O&M) costs by 30%. This initiative can be sustained through the regular municipal budget of the ULB as well as the revenue generated from the sale of recyclables and compost. However, for centralised infrastructure and rehabilitation of the dump site, financial aid would be required. This model of championship has been replicated in Guntur and Visakhapatnam in Andhra Pradesh, and many other municipalities have showed interest in doing the same to set up an efficient system of awareness raising and of segregation, recycling, and transportation of waste.

*Source: WMC*

## 2.3 COLLECTION AND TRANSPORTATION

### 2.3.1 SOLID WASTE MANAGEMENT RULES, 2016 - REQUIREMENTS ON PRIMARY / SECONDARY COLLECTION AND TRANSPORTATION

As per SWM Rules, 2016:



Clause 15: Duties and responsibilities of local authorities:-

- (b) arrange for door to door collection of segregated solid waste from all households including slums and informal settlements, commercial, institutional and other non-residential premises. From multi-storage buildings, large commercial complexes, malls, housing complexes, etc., this may be collected from the entry gate or any other designated location;
- (f) prescribe from time to time user fee as deemed appropriate and collect the fee from the waste generators on its own or through authorised agency;
- (h) setup material recovery facilities or secondary storage facilities with sufficient space for sorting of recyclable materials to enable informal or authorised waste pickers and waste collectors to separate recyclables from the waste and provide easy access to waste pickers and recyclers for collection of segregated recyclable waste such as paper, plastic, metal, glass, textile from the source of generation or from material recovery facilities; Bins for storage of bio-degradable wastes shall be painted green, those for storage of recyclable wastes shall be printed white and those for storage of other wastes shall be printed black;
- (i) establish waste deposition centres for domestic hazardous waste and give direction for waste generators to deposit domestic hazardous wastes at this centre for its safe disposal. Such facility shall be established in a city or town in a manner that one centre is set up for the area of twenty square kilometers or part thereof and notify the timings of receiving domestic hazardous waste at such centres;
- (j) ensure safe storage and transportation of the domestic hazardous waste to the hazardous waste disposal facility or as may be directed by the State Pollution Control Board or the Pollution Control Committee;
- (k) direct street sweepers not to burn tree leaves collected from street sweeping and store them separately and handover to the waste collectors or agency authorised by local body;
- (m) collect waste from vegetable, fruit, flower, meat, poultry and fish market on day to day basis and promote setting up of decentralised

- compost plant or biomethanation plant at suitable locations in the markets or in the vicinity of markets ensuring hygienic conditions;
- (n) collect separately waste from sweeping of streets, lanes and by-lanes daily, or on alternate days or twice a week depending on the density of population, commercial activity and local situation;
  - (o) set up covered secondary storage facility for temporary storage of street sweepings and silt removed from surface drains in cases where direct collection of such waste into transport vehicles is not convenient. Waste so collected shall be collected and disposed of at regular intervals as decided by the local body;
  - (p) collect horticulture, parks and garden waste separately and process in the parks and gardens, as far as possible;
  - (q) transport segregated bio-degradable waste to the processing facilities like compost plant, biomethanation plant or any such facility. Preference shall be given for on site processing of such waste;
  - (r) transport non-bio-degradable waste to the respective processing facility or material recovery facilities or secondary storage facility;
  - (s) transport construction and demolition waste as per the provisions of the Construction and Demolition Waste management Rules, 2016;

### 2.3.2 GENERAL PRINCIPLES

Collection of segregated municipal waste is an essential step in MSWM. Inefficient waste collection services have an impact on public health and aesthetics of towns and cities. Collection of wet, dry and domestic hazardous waste separately ensures maximum recovery of recyclables. It also enhances the potential of cost-effective treatment of such wastes which can then easily meet the minimum quality criteria defined for different products, eg. production of compost from pure organic waste.

Waste collection services are divided into primary and secondary collection. Primary collection refers to the process of collecting, lifting and removal of segregated solid waste from source of its generation including households, shops, offices, markets, hotels, institutions and other residential or non-residential premises and taking the waste to a storage depot or transfer station or directly to the disposal site, depending on the size of the city and the waste management system prevalent in the city. Primary collection must ensure separate collection of certain waste streams or fractions depending on the separation and reuse system applied by the respective town or city (Section 2.2).

Secondary collection includes picking up waste from community bins, waste storage depots, or transfer stations and transporting it to waste processing sites or to the final disposal site. At the secondary collection



Primary collection refers to the collection of waste from source of generation



Secondary collection is the collection of waste from community bins, storage depots, or transfer stations for transportation to processing or disposal site

points, segregated waste must be stored on-site in separate covered bins or containers for further collection and should be kept separate during all steps of waste collection, transportation, and processing. Further, ULBs should ensure that at the secondary storage points the waste is should be attended daily or before container starts overflowing.

A well synchronized primary and secondary collection and transportation system, with regular and well communicated intervals of operation (with respect to primary collection), is essential to avoid containers' overflow and waste littering. Further, the transport vehicles should be compatible with the equipment design at the waste storage depot and should be able to transport segregated waste. They should also be easy to maintain. It should be ensured that waste collected from the doorstep in motorized vehicles should be either directly transported to the processing facility or through material recovery facility or transfer station, or waste storage depots for facilitating, sorting, and bulk transfer of waste. The vehicles used for transportation should be covered and not visible to public. It should have a facility to prevent spillage of waste and leachate en-route to the processing or disposal facility.

Figure 2.3, Figure 2.4, and Figure 2.5 as well as Figure 1.7 (of Part I) indicate suggested movement of household waste, market waste, street sweeping, and drain silt through the MSWM system.

It is essential to separate street sweeping waste and silt cleaned from drains completely from household waste streams through all stages of collection, transport, and treatment, since street sweeping and drain silt can be infiltrated with significant amounts of toxic substances (e.g., heavy metals) and are often responsible for contamination of waste streams envisaged for composting and recycling. Accordingly, street sweeping and drain silt are covered in different flowcharts. For household waste, a tertiary collection system is necessary only in large cities where transfer stations are located at a great distance (more than 15 km) from disposal and treatment facilities.

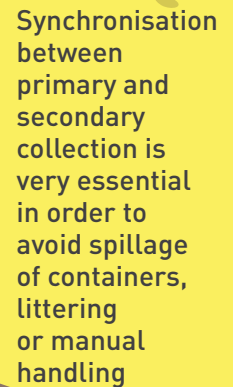

Synchronisation between primary and secondary collection is very essential in order to avoid spillage of containers, littering or manual handling

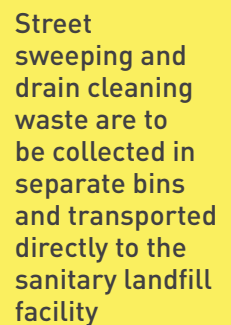

Street sweeping and drain cleaning waste are to be collected in separate bins and transported directly to the sanitary landfill facility

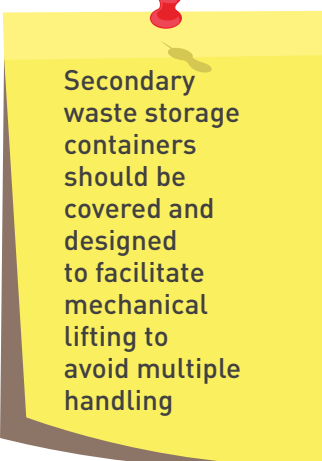

Secondary waste storage containers should be covered and designed to facilitate mechanical lifting to avoid multiple handling

Figure 2.5: Flow Chart for Household Waste Collection, Transportation and Disposal<sup>10</sup>

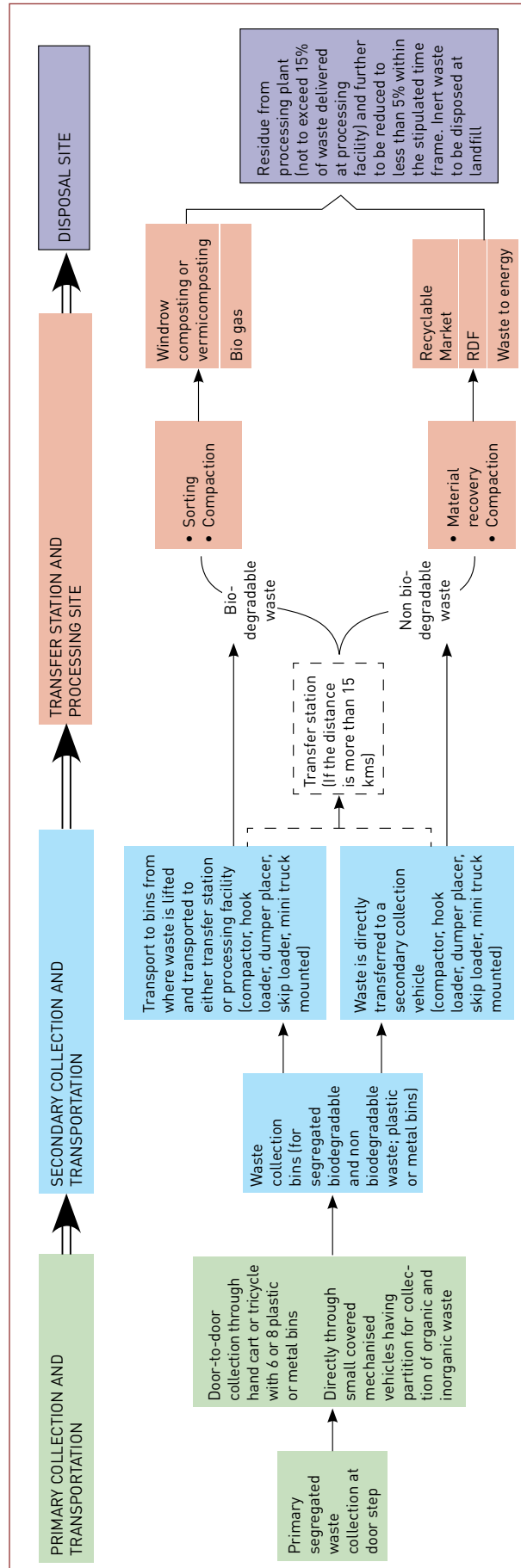

- The compactor is an appropriate vehicle for collecting biodegradable and recyclable component of MSW
- Skip loaders/ Hook loaders are preferred for collecting inert waste or Construction and Demolition waste
- Waste may be transferred to the transfer station if the processing site is located at least 15 kms away from the city

10 Developed by the Expert Committee for revision of MSWM Manual (2013 - 15).



Figure 2.6: Flow Charts for Collection, Transportation and Disposal of Street Sweeping and Drain Silt<sup>11</sup>

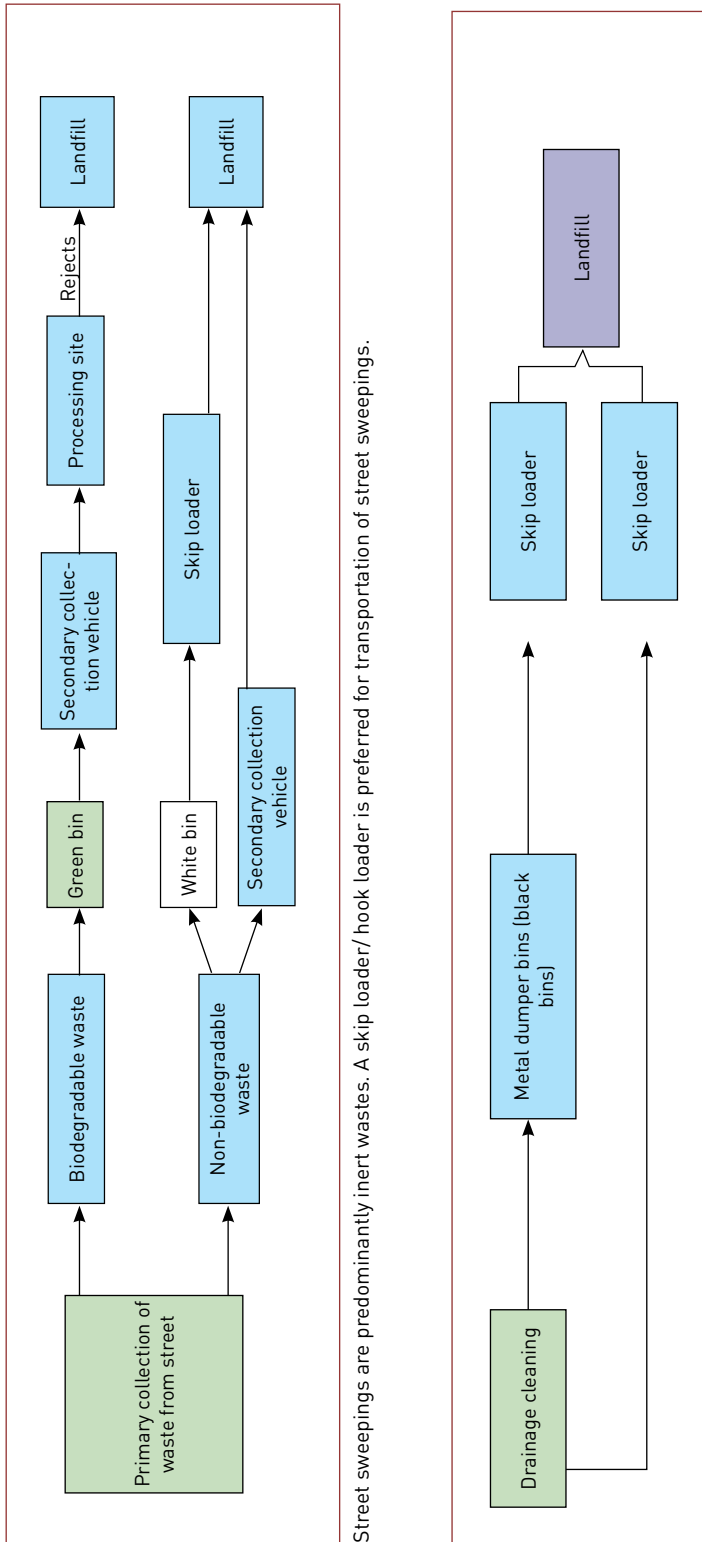

Street sweepings are predominantly inert wastes. A skip loader/ hook loader is preferred for transportation of street sweepings.

11 Developed by the Expert Committee for revision of MSWM Manual (2013-15).

Only in cases where the processing or disposal facilities are more than 15 km from the collection area that transfer stations should be provided

**Figure 2.7: Flow Chart for Collection, Transportation and Disposal of Vegetable Market Waste<sup>12</sup>**

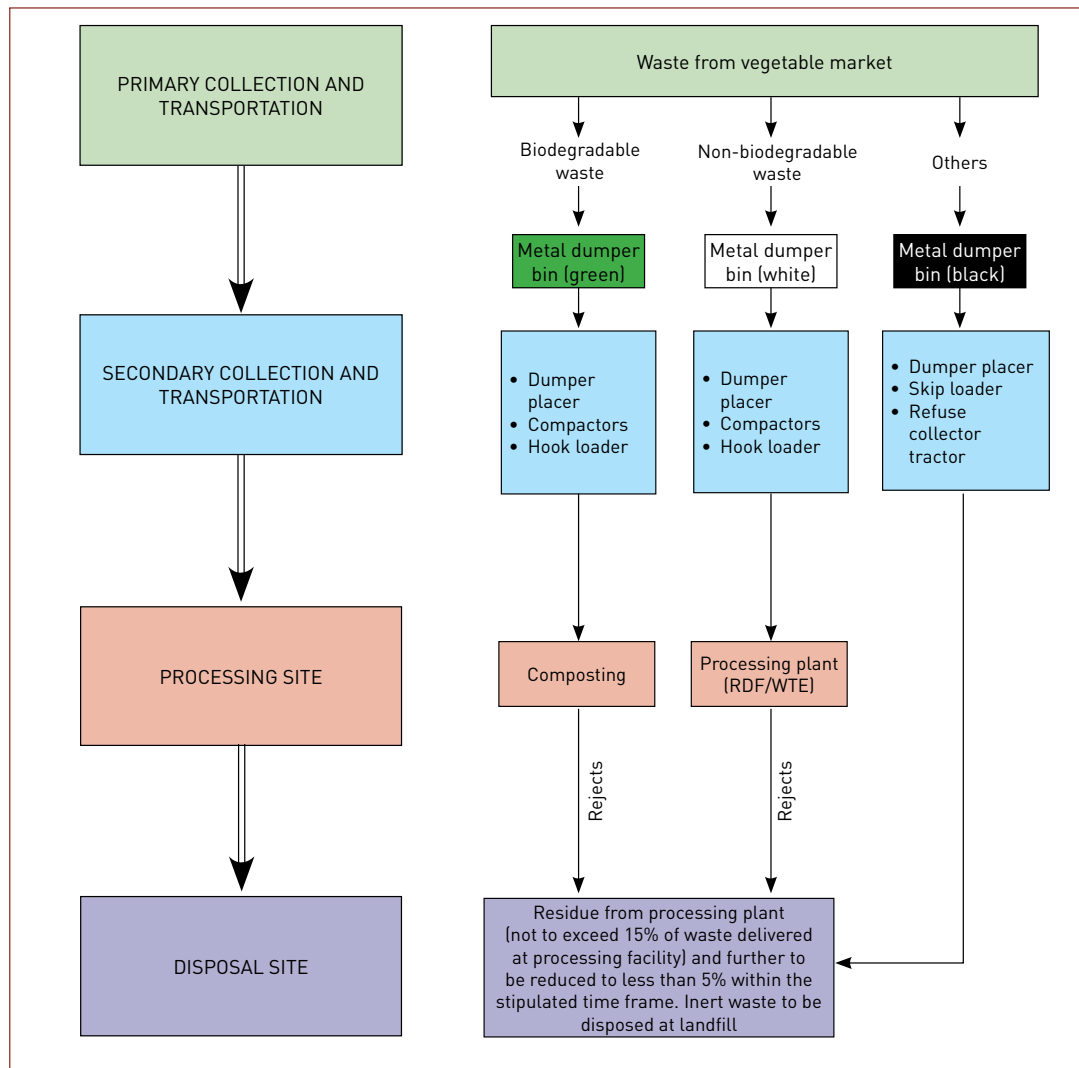

### 2.3.3 PRIMARY COLLECTION

#### 2.3.3.1 LOCATION AND ORGANISATION OF PRIMARY COLLECTION

Primary collection of segregated MSW from individual households and establishments (door-to-door collection) is accomplished through the use of containerised pushcarts, tricycles or small mechanised vehicles, compactors, or tipping vehicles depending on the terrain of the locality, width of streets, and building density.

Spacious and well-lit safe neighbourhoods allow collection systems with compactor vehicles and tipping equipment which are more efficient. Narrow streets do not allow for the use of conventional primary collection vehicles. In cramped neighbourhoods, handcarts or pushcarts,

<sup>12</sup> Developed by the Expert Committee for revision of MSWM Manual (2013-15).



or tricycles or small mechanised vehicles may be used for door-to-door collection of waste, which may then be transferred to a larger vehicle in the vicinity. Where access to individual houses or establishments is difficult, handcarts or rickshaws could be made to stand at designated spots.

In hilly areas, many of the houses are accessible only by footpaths or steps, thus restricting the use of handcarts and tricycles. Segregated waste from households in hilly areas should be collected using backpacks having small leakproof containers up to 50l capacity or using local traditional load-bearing methods like pack animals, shoulder poles, headbands, wheeler bags, etc. The waste collectors should ideally collect wet waste from each household with a bag or basket on their back and with another bag for dry waste. The waste collectors should be well equipped with personal protective equipment (PPE) and should also be provided with a whistle to announce their arrival for waste collection.

Waste collection route planning is critical to ensure an efficient door-to-door collection and transportation system. In hilly areas, waste collection should ideally start at the highest point and proceed to lower levels. This would ensure that waste collectors or waste collection vehicles need not carry increasing amounts of waste up steep slopes.

The frequency of door-to-door collection should be determined by the density of population, collection system, and climatic conditions. In hot and humid regions, at least wet waste is to be collected on a daily basis. Isolated houses, shops, and establishments may be served on a less than daily basis, depending on the quantities of waste generated. Motorised collection vehicles are able to handle relatively larger quantities of waste and are preferred for periodic waste collection.

Domestic waste should be collected in the morning. Waste from the commercial areas should be collected between 10a.m. and 2p.m. Vegetable market waste should be collected in nonpeak hours (early morning, late afternoon, or at night). The collection of market waste might also need to be done more than once a day.

The municipal authority may engage with RWAs, CBOs, NGOs, SHGs, or the private sector in providing door-to-door collection services. Penal provisions may be introduced after assessment or review of overall management system for failure of service where contracts are awarded.



Frequency of collection is determined by the density of area, collection system, and climatic conditions. For instance, wet waste should be collected daily in hot and humid areas



## **Door-to-Door Garbage Collection - An initiative of Shimla Municipal Corporation and Shimla Environment, Heritage Conservation and Beautification Society**

**Location:** Shimla

**Main Players:** Shimla Municipal Corporation (SMC), Shimla Environment, Heritage Conservation and Beautification (SEHB) Society

**Year of Start:** 2010

**Approach:** Shimla, the capital city of Himachal Pradesh, with its strong cultural heritage and panoramic scenic beauty, is among the most famous tourist destinations in India. Due to a rapidly growing population and poor infrastructure toward the end of 20<sup>th</sup> century, hygiene, sanitation, and public health became a cause of concern for the city. The initiatives taken by SMC to deal with the solid waste menace and overall situation remained largely unsatisfactory, wherein SMC undertook three door-to-door collection initiatives involving various NGOs and voluntary organisations during 1999–2008. However, concerns raised by the local people, which was followed by a writ petition, resulted in the High Court of Himachal Pradesh issuing directions to improve the solid waste management (SWM) system. Subsequent to the directions of the High Court, the Urban Development Department notified door-to-door collection initiative for Shimla in 2006. This led to the establishment of SEHB Society registered under the Himachal Pradesh Societies Registration Act, in 2009.

Under this initiative, the following approaches were adopted to bring about significant improvements in SWM system.

### **Institutional and Managerial:**

- The Municipal Commissioner headed the SEHB Society's waste collection initiative and was responsible for overall supervision, along with the Corporation Health Officer as member secretary of the society. The SEHB staff, which was supervised by the Chief Sanitary Inspector, looked after collection and transportation services.
- A dedicated team was allocated for smooth functioning of the system. There were two coordinators for SEHB. All 25 wards had a dedicated supervisor and assistant supervisor reporting to the coordinators, who in turn report to the sanitary inspectors.
- A mechanism for collection was defined through physical verification of households and communities.
- Optimisation of routing of each vehicle and provision of a substitution plan for any breakdown in vehicles was established.
- Centralised complaint redressal system within SMC and dedicated telephone lines at SEHB office were established to resolve the complaints of users. Feedback registers were updated daily.
- Regular monitoring was done by the health officer and sanitary inspectors, as well as pre-arrangement or substitution of the workers to maintain efficiency in case of absences from work or during holidays.
- Effective and timely remittance of salaries of the field staff was maintained.

- SMC provided identity cards to SEHB Society's workers and also employee provident fund benefits and employees' state insurance benefits.
- Regular health checkup of garbage collectors was performed.
- Woman participation was encouraged through different modalities like providing easy terrain to work, working close to their homes, and husband and wife working in same wards.

#### **Legal:**

- Door-to-door collection bye-laws were introduced with special mandate for citizens to hand over the MSW to SEHB Society, the agency authorised by SMC.
- SMC introduced user charges and its provision within the bye-laws for compliance.
- Penal provisions were introduced for non-compliance of citizens, e.g., littering and non-participation in the door-to-door collection system.

#### **Information, Education and Communication:**

- For increasing community participation in this initiative, SMC organised community meetings to disseminate the details of the collection system and its functioning.
- Mass media (jingles for radio channels, local advertisements) and print media were used to further promote the initiative and sensitise people.
- Ward-level lucky draw was carried out for registered users.
- SEHB Society distributed its annual calendar, with all necessary information and messages, to the households.
- SEHB's case study and brochure were disseminated for further outreach and to sensitise people to the initiatives taken.

#### **Outcome:**

- More than 90% of coverage (25 wards) and collection of waste from the households was achieved.
- Redressal of complaints by the ward supervisors for nondelivery of service was effective and timely.
- The initiative was compliant with laws pertaining to the municipal solid waste management (MSWM).
- Overall environmental improvement and aesthetic value of the city was achieved.
- There were less incident of monkey nuisance and conflict.

#### **Success Factor:**

- A strong political and administrative will to improve the MSW system in the city.
- Strategic planning and revisiting or assessing the existing situation.
- Intensive campaigning of officials and interaction with citizens regarding the door-to-door collection system.
- Effective monitoring and follow-up by officials.
- Penalty provisions for littering and noncompliance in the door-to-door collection system through bye-laws.

### Overall Sustainability:

Collection of user charges has resulted in the financial sustainability of the project. There has been a steady rise in the user charges collection during the last financial year. A dedicated team has been appointed for maintaining the regular cash flow which is essential to payment of salaries and operational liabilities of the self-financing scheme. Strict monitoring is carried out to ensure the collection revenues as well as the overhead expenditures.

Source: SMC

## 2.3.4 VEHICLES AND EQUIPMENT FOR PRIMARY COLLECTION

Primary collection vehicles should meet local requirements. Before selecting a vehicle for primary collection, it is advisable to assess the amount of waste generated, local climatic conditions, topography of the area, and available facilities for repair and maintenance of vehicles.



### Vehicles Typically Used for Primary Collection

- Handcarts or tricycles with containers or bins
- Tricycles with hydraulic tipping containers
- Light commercial vehicles (mini trucks) with hydraulic tipping containers
- Four-wheeled mini trucks with international standard garbage collection bins

### 2.3.4.1 HANDCARTS OR TRICYCLES WITH CONTAINERS OR BINS

Handcarts should have a capacity to carry 4 to 6 containers of 40 to 60l capacity. The containers should be green for wet waste and blue for dry waste (Figure 2.8). Bins should be made of HDPE, injection or roto molded, UV tested, and universally used as standard garbage handling bins.

Containerised handcarts are suitable for door-to-door collection of MSW from households, shops, and establishments from narrow lanes and hilly areas and also for collection of street sweepings where women sanitation workers are involved. Bins or containers can be easily unloaded into secondary collection bins or secondary transport vehicles based on the prevalent collection and transportation system in the ULB. This can be done without depositing the waste on the ground, avoiding multiple handling of waste.

Tricycles with 6 to 8 containers of 40 to 60 l capacity can also be used for door-to-door collection of waste from narrow lanes. Male workforce is engaged to facilitate the picking up of larger quantity of waste in one trip and taking the waste to a secondary waste storage depot placed at a longer distance. Refer to Section 2.4.3 of Part II for the more details about the types of equipment for street sweeping.

Figure 2.8: Hand Carts with Bins<sup>13</sup>



#### 2.3.4.2 TRICYCLE WITH HYDRAULIC TIPPING CONTAINERS

MSW tricycles should have mild steel epoxy painted and tipping containers of 350l (140 kg per trip). The tipping containers should be mounted on a standard tricycle (Figure 2.9). These tricycles are suitable for door-to-door collection from small lanes and small waste generators.

Figure 2.9: Tricycle with Hydraulic Tipping Container<sup>14</sup>



#### 2.3.4.3 LIGHT COMMERCIAL VEHICLES (MINI TRUCKS) WITH HYDRAULIC TIPPING CONTAINERS

These vehicles are suitable for door-to-door collection of segregated waste for lanes with less than 5m width. They have a total payload capacity of nearly 600–900 kg per trip. The load height is approximately 1,500 mm from the ground level. They should have a leakproof MS

<sup>13</sup> Source taken from Manufacturer

<sup>14</sup> Ibid.

Adequate repair and maintenance system should be established for mechanical and manual vehicles and other heavy equipment to lower potential downtime

load body with drainage tube and plug. The small tipper should be built on a suitable chassis. These vehicles should have four openings, two on each side to facilitate direct transfer of waste from a domestic bin to the vehicle. They can also have a central removable partition to facilitate storage of segregated waste. It is desirable to use up to 3m<sup>3</sup> capacity vehicle for door-to-door collection to cater to a large number of houses in a single trip (Figure 2.10).

**Figure 2.10: Mini Truck with Hydraulic Container**



#### **2.3.4.4 FOUR-WHEELED MINI TRUCKS WITH INTERNATIONAL STANDARD BINS**

Normally the practice is to unload the small containers manually into the bin or the hydraulic container. The main advantage of the four wheeled mini truck using bins instead of a hydraulic container is that the loading height can be decreased from 1,500mm to 1,200mm or less from bins placed on the ground. For the same logic, this type of system cannot be fitted on the larger chassis because then the loading height would be even higher. Avoidance of hydraulic tipping will make these trucks suitable in remote places, where provisions for maintenance of the hydraulic component of a large number of vehicles may not be available. Further, maintenance is costly and time-consuming.

A typical setup is that the vehicle can carry 8 bins of minimum 240 l. Bins should be made of injection or roto molded HDPE. Each mini truck should carry 4 green containers for wet waste and 4 blue containers for dry waste.

ULBs should have adequate workshop facilities for the maintenance not only of their fleet of vehicles, but also of containers, handcarts, etc. The workshop, public or private sector, or public–private partnership (PPP) should have adequate technical staff (trained men and women), spares, and preventive maintenance schedules to ensure that at least 80% of the vehicles run on the road each day and the downtime is minimised to the extent possible. For more information on preventive maintenance, refer to Section 6.3 of Part II.

### 2.3.5 STAFFING AND EQUIPMENT REQUIREMENTS FOR PRIMARY COLLECTION



Clause 15: Duties and responsibilities of local authorities:-

(zd) ensure that the operator of a facility provides personal protection equipment including uniform, fluorescent jacket, hand gloves, raincoats, appropriate foot wear and masks to all workers handling solid waste and the same are used by the workforce;

Efficient primary collection requires adequate equipment, facilities, and trained staff. Table 2.2 below gives specifications of the requisite primary waste collection service systems to be deployed in different types of localities. Table 2.3 gives service norms for deployment of vehicles and staffing for primary collection of waste. The specific requirement for equipment or vehicles should be calculated based on waste generation projections of the city (at least for the coming 5 years).

**Table 2.2: Elements of Primary Waste Collection System**

| SOURCE                               | PRIMARY COLLECTION SERVICES   | TRANSPORTATION   | PPE FOR WASTE HANDLER                                    |
|--------------------------------------|---|--|--|
| Societies/<br>Apartment<br>Complexes | <ul style="list-style-type: none"> <li>Door-to-door collection services with a minimum of 2 bins for collection of wet waste and dry waste (10–15 l)</li> <li>A pair of community bins of               <ul style="list-style-type: none"> <li>- 60 litres (20 to 30 kg) or</li> <li>- 120 litres capacity (40 to 60 kg) or</li> <li>- 240 litres capacity (80 to 120 kg) or</li> <li>- 1.1 cu. m capacity (300 to 450kg) depending on number of houses to be served (i.e. 12, 24, 48, 200 units). The specifications should be as per Central Institute of Plastics Engineering and Technology (CIPET) specification</li> </ul> </li> <li>Contract for door-to-door collection with private sector, CBOs, NGOs, RWAs, or SHGs</li> </ul> | Containerised light weight handcarts<br><br>Tricycles for both men and women<br><br>Pickup vans<br><br>Motorised waste collection vehicle<br><br>Any suitable combination of the above | Gloves<br><br>Shoes<br><br>Clothes that cover whole body |

**Table 2.2: Elements of Primary Waste Collection System [contd.]**

| <b>SOURCE</b>                  | <b>PRIMARY COLLECTION SERVICES</b>  | <b>TRANSPORTATION</b>  | <b>PPE FOR WASTE HANDLER</b>  |
|--------------------------------|---|--|---|
| Inaccessible Residential Areas | <ul style="list-style-type: none"> <li>• 2 community bins or containers of 60–120 l capacity for 20–40 dwelling units</li> <li>• 2 domestic bins for storage of waste at source—5, 10, 15, 20 l (for 2–8 kg waste) capacity, as per CIPET specification</li> </ul>  | <ul style="list-style-type: none"> <li>• Containerised light weight hand carts</li> <li>• Tricycle for both men and women</li> <li>• Waste collected from the area should be transferred to a light commercial vehicle (LCV) outside the slum area.</li> </ul> | <p>Gloves</p> <p>Shoes</p> <p>Clothes that cover whole body</p>                             |
| Residential areas              | <ul style="list-style-type: none"> <li>• Door-to-door collection services for segregated waste</li> <li>• 12–15 l capacity domestic bins, one of them with lid, made as per CIPET specification</li> <li>• Contract for door-to-door collection with private sector, NGOs, RWAs, or SHGs</li> </ul>   | <ul style="list-style-type: none"> <li>• Containerised handcarts</li> <li>• Tricycles for both men and women</li> <li>• Pickup vans</li> <li>• Motorised waste collection vehicle</li> </ul>   | <p>Gloves</p> <p>Shoes</p> <p>Clothes that cover whole body</p>                             |
| Markets/ Bulk Waste Generators | <ul style="list-style-type: none"> <li>• Doorstep collection services for recyclable material or dedicated waste streams on full cost recovery basis</li> <li>• Markets: 1.1–4.0m<sup>3</sup> covered bins for storage of waste as per the quantity of waste generated in the market</li> <li>• Large commercial complexes: 3.0–7.0m<sup>3</sup> containers</li> </ul>  | <ul style="list-style-type: none"> <li>• Motorised waste collection vehicle with container lifting device</li> <li>• Compactors compatible with containers</li> <li>• Non-compactor trucks</li> </ul>  | <p>Heavy duty gloves</p> <p>Shoes</p> <p>Clothes that cover whole body</p> <p>Face mask</p> |
| Hilly areas                    | <ul style="list-style-type: none"> <li>• Door-to-door collection service for segregated waste—manual collection or with small motorised vehicles</li> <li>• Door-to-door collection service for segregated waste—5, 10, 15, 20 l (for 2–8 kg waste) capacity, HDPE, injection molded, tested bins</li> <li>• 2 domestic bins of 12–15 l or a pair of community bins of 60, 120, 240 l depending on the number of houses to be served ( 20, 40, or 80 houses)</li> </ul> | <ul style="list-style-type: none"> <li>• Lightweight containerised handcarts</li> <li>• Tricycles for both men and women</li> <li>• Pickup vans</li> <li>• Motorised waste collection vehicle</li> <li>• Combination of vehicles specified above</li> </ul>    | <p>Heavy duty gloves</p> <p>Shoes</p> <p>Clothes that cover whole body</p> <p>Face mask</p> |



**Table 2.3: Estimates for Deployment of Vehicles and Manpower for Primary Collection<sup>15</sup>**

| VEHICLE FOR PRIMARY COLLECTION                                | NUMBER OF HOUSEHOLDS TO BE COVERED IN DIFFERENT AREAS  | POPULATION SERVED  | STAFF REQUIRED                  |
|---|--|--|---------------------------------|
| Push Carts  | <ul style="list-style-type: none"> <li>Congested area: 250 - 300</li> <li>Medium Density area: 200</li> <li>Scattered Area: 125</li> <li>Hill area: 85-90</li> </ul> | <ul style="list-style-type: none"> <li>1,250–1,500</li> <li>1,000</li> <li>625</li> <li>400–450</li> </ul>                                       | 1 person per push cart          |
| Tricycle  | <ul style="list-style-type: none"> <li>Congested area: 300</li> <li>Medium Density area: 250</li> <li>Scattered Area: 200</li> <li>Hilly area: 125</li> </ul>        | <ul style="list-style-type: none"> <li>1,500</li> <li>1,250</li> <li>1,000</li> <li>Should be decided based on operational conditions</li> </ul> | 1 person per tricycle           |
| Light Commercial Vehicles (LCV) having 500 to 700 kg capacity | <ul style="list-style-type: none"> <li>1,000</li> </ul>  | <ul style="list-style-type: none"> <li>5,000</li> </ul>  | 1 driver and two labour per LCV |
| LCV with more than 700 kg capacity                            | <ul style="list-style-type: none"> <li>1,500 to 2,000</li> </ul>   | <ul style="list-style-type: none"> <li>7,500 to 10,000</li> </ul>  | 1 driver & two labour per LCV   |

(Note: Compactor may not be used for primary collection purposes)

### 2.3.6 COMMUNITY INVOLVEMENT IN PRIMARY COLLECTION

Community participation in waste management activities is critical for ensuring a well-functioning collection system. Involvement of the community in the primary collection system, specifically in determining the timings for waste collection, is important for the effective planning and implementation of the primary waste collection system. Community initiatives need to be inclusive. Active engagement of men, women, youth, and children should be given equal importance. Separate group discussions, involvement of community leaders, community associations, SHGs, and local members who represent the interest of the community at large (especially with a focus on bringing in the voices of women) must be adopted.

ULBs should make concerted efforts to integrate the informal sector of waste pickers into regular waste collection operations through the private sector, NGOs, RWAs etc.

<sup>15</sup> Reference Material on Municipal Waste Management for Urban Local Bodies (2012). All India Institute of Local Self-Government (AIIILGS).

## 2.3.7 ROLE OF THE INFORMAL SECTOR IN PRIMARY WASTE COLLECTION



As per SWM Rules, 2016 ULBs are directed to:

Clause 15: Duties and responsibilities of local authorities:-

(c) establish a system to recognise organisations of waste pickers or informal waste collectors and promote and establish a system for integration of these authorised waste-pickers and waste collectors to facilitate their participation in solid waste management including door to door collection of waste;

(d) Facilitate formation of Self Help Groups, provide identity cards and thereafter encourage integration in solid waste management including door to door collection of waste;

h) setup material recovery facilities or secondary storage facilities with sufficient space for sorting of recyclable materials to enable informal or authorised waste pickers and waste collectors to separate recyclables from the waste and provide easy access to waste pickers and recyclers for collection of segregated recyclable waste such as paper, plastic, metal, glass, textile from the source of generation or from material recovery facilities; Bins for storage of bio-degradable wastes shall be painted green, those for storage of recyclable wastes shall be printed white and those for storage of other wastes shall be printed black

The informal sector in any city includes the kabadiwalas or scrap dealers (the kabadi system) and the waste pickers. The involvement of the informal sector should be examined and integrated into the waste management system of the city.

The kabadi system network forms an important link in the overall waste recycling system prevalent in the country. The kabadi system or scrap dealers can be compared to micro-entrepreneurs who buy reusable and recyclable material like newspapers, metal, glass, cardboards, plastics, etc. The kabadi system is involved in the purchase of about 70%–75% of recyclables in the country from households and commercial establishments. In this informal sector, there are individuals, families, groups, and small enterprises that carry out unregistered and unregulated activities. People who are part of the local kabadi system purchase recyclable waste from households, shops, and establishments. They segregate this waste in plastic, paper, metal, cardboard, glass, e-waste, etc. and then sell the segregated waste to the large wholesalers. The large wholesaler is the final link between the recycling factory and the kabadi, and can extend credit, bargain, etc.

Recycling carried out by informal sector (individual or group of waste pickers) plays a critical role in reducing waste quantities and depletion of raw materials as well as minimising the financial and environmental burden of cities

There is another set of informal sector known as waste pickers who also play an important role in the informal recycling system. They are instrumental in recovering discarded recyclable waste from the streets, bins, dump sites, etc. They pick up 5%–10% of the recyclables from the municipal waste to earn their living (Figure 2.11). This informal sector helps to reduce the depletion of raw material, natural resources, and energy that otherwise would be used in the production of virgin or new products. Sorting of discarded waste by the informal sector or waste pickers also occurs on the street corners, at municipal bin level, and at the dump sites where the waste pickers sort the recyclable material from the mixed waste.

This form of mixed waste is fraught with danger and makes the waste pickers susceptible to injuries and infections. Moreover, a lot of waste pickers or ragpickers are usually harassed by the police, property owners, and shop keepers. Many of them have to justify their work to various people and are condemned by society. Many of these waste pickers are women who have to live with constant insecurity, harassment, and threat to their livelihood.

In order to avoid child labour and unhealthy practice of segregation of recyclable material from soiled and infected waste without use of personal protective equipment (PPE), as well as to reduce exploitation and discrimination of this low-income group, municipal authorities should make concerted efforts to integrate the informal sector of waste pickers into regular waste collection operations through the private sector, NGOs, CBOs, SHGs, and RWAs.

The aim should be to raise the status from waste pickers to waste collectors and provide them with working tools and PPE like gloves, shoes, full sleeves coat, etc. The following are important prerequisites for defining any initiative to integrate informal sector into the formal system: (i) assessing the size of the existing informal system, (ii) assessing the quantity of material being handled, (iii) identifying the number of waste pickers and persons that are part of the kabadi system, and (iv) identifying their linkages to the wholesale market.

With the help of local NGOs, the informal sector can be organized to form viable business groups, cooperatives or societies and would be an ideal approach for achieving their integration. Such initiatives should be supported by appropriate local policies and bye-laws. This would result in institutionalizing and ensuring rights of workers (both men and women) in the entire process.

Waste pickers should be encouraged to form cooperatives through the involvement of local NGOs or self-help groups (SHGs), and should be allowed to collect recyclables from households. Cooperatives tend to



Informal recycling activities reduce environmental costs and also provide employment opportunities. However, ensuring hygienic conditions and environmentally sound recycling practices is a challenge

Waste pickers are instrumental in recovering recyclables that have not been bought by the kabadiwalas

protect their rights, thereby retaining their dignity of labor and right to livelihood, i.e., right to access recyclables. Such initiatives will not only ensure a higher level of income for waste pickers, but will also ensure hygienic conditions for waste pickers and environmentally safe waste recycling practices.

Provision of social security and welfare benefits to waste pickers should also be considered. As a general rule, any form of health problems related to occupational health hazards should be addressed appropriately. Social benefits of workers should include health checkups, medical health care, and treatment facilities. Care must be taken to ensure that workers (be they contractual or otherwise) have access to proper facilities such as separate toilets for men and women, storage space for their belongings, etc. For further information, please refer to Section 1.4.5.9 of Part II.

**Figure 2.11: Waste picker with recyclable material**





## Organizing the Unorganised: Toward Formalisation and Social Inclusion of Informal Waste Pickers and Recyclers

**Location:** Pune, Pimpri Chinchwad, Maharashtra

**Main Players:** Kagad Kach Patra Kashtakari Panchayat (KKPKP), Solid Waste Collection and Handling (SWaCH), Pune Municipal Corporation (PMC), and Pimpri Chinchwad Municipal Corporation

**Year of Start:** KKPKP 1993, SWaCH-2007

**Approach:** KKPKP is a registered trade union of waste pickers, scrap collectors, and itinerant buyers working in the cities of Pune and Pimpri Chinchwad (Maharashtra). It was founded in 1993 with 800 members to secure their livelihood and restore their dignity and rights as workers and as citizens. It was formed on the basic premise that scrap collection is “work” and scrap collectors are “workers.” In 2013, KKPKP has around 9,000 members, most of whom are Dalit women. In 1998, KKPKP promoted Kagad Kach Patra Nagari Sahakari Pat Sanstha (KKPNSPS), a savings-linked credit cooperative of waste pickers.

In 2007, KKPKP promoted SWaCH, a waste pickers cooperative. SWaCH is the institutionalised outcome of a pilot project jointly undertaken by KKPKP, SNDT Women’s University, and the PMC. The autonomous social enterprise provides front-end waste management services that include door-to-door waste collection, composting, and biogas plant operation and maintenance through an agreement with the PMC. For the Pimpri Chinchwad Municipal Corporation, 350 members of KKPKP also work as contract workers in door-to-door collection.

In PMC, 2,300 SWaCH members service 400,000 households, offices, shops, and small commercial enterprises. The workers of SWaCH are not municipal employees but have been authorised to recover user fees for the services that they provide. Each worker provides door-to-door waste collection services to about 100–150 households and is paid Rs20–Rs30 per household per month by the service user. The worker also has rights over the recyclable materials. Together, the workers earn minimum or higher than minimum wages with flexible hours of work. Collection is carried out using pushcarts and motorised waste collection vehicles. Collection and safety equipment and space for material recovery are provided by the PMC. Between 2012 and 2013, SWaCH has cost the PMC a total of Rs. 3.63 crore, which amounts to Rs. 2 per household per month, the lowest spent by any municipality in the country. A proposal for provision of social security and welfare benefits to waste pickers is under consideration.

### Institutional Structure:

KKPKP is a democratic membership organisation. Its office bearers include the President, General Secretary, Joint Secretary, and Treasurer. The main decision-making body is the Representatives Council of 80 members, largely women. The Council meets once a month for deliberating and resolving issues. The education level of the members varies from illiterate to class 12 who take care of the functions of the union. The union also has a few hired staff, quite a few of whom are members’ children. All members pay an annual membership fee.

### **Approaches for Economic, Social and Political Inclusion:**

Waste pickers are an economically marginalised, socially excluded, and politically disempowered occupational community. The KKPKP therefore relies on the twin strategies of struggle and agitation for rights and social justice as well as reconstruction through institutional alternatives. Institutionally, SWaCH and KKPNSPS deal more with economic and financial inclusion, while the KKPKP focuses more on social and political inclusion and addressing injustice and inequality.

The following are the approaches for economic, social, and political inclusion:

- Seeking state recognition of scrap collectors as “workers” and scrap collection as “work”
- Organizing and mobilizing scrap collectors into a trade union so that they are recognised as workers
- Visibility and voice for waste pickers as workers, dalits, women, and citizens
- Seeking municipal recognition and legitimacy through issue of photo identity cards for contribution to waste management and recycling
- Rights to access recyclables
- Claims on government resources such as space for material recovery centers, collection and safety equipment, children’s scholarships, medical and life insurance, and welfare benefits
- Market interventions for fair trade and labour practices in the scrap trade
- Revision and restructuring of solid waste management to include labour, governance and environmental concerns
- Engagement in citizenship rights and governance

### **Outcome:**

- Waste pickers recognition as workers and scrap collection as work in Maharashtra and some other states through provision of identity cards in various government documents, such as the Bajaj Commission Report, Second National Labour Commission Report, and Plastic Waste (Management and Handling) Rules.
- Entitlements to collection equipment, medical and life insurance, educational benefits for children
- Inclusion as an occupational category under the Socio-economic Caste Census and Antyodaya beneficiaries under the Food Security Act, 2013
- PMC provided identity cards to KKPKP workers in 1995–1996 and later provided medical insurance and educational scheme benefits to all registered waste pickers.
- Pimpri Chinchwad provided dedicated space for sorting and segregation of waste in 1998.
- Organised door-to-door collection and transportation services for the citizens through SWaCH and KKPKP since 2006
- SWaCH and KKPKP have organised drop-off points for collection of municipal waste, e-waste and old clothes, environmental awareness campaigns, and other outreach programmes for the citizens.

### Contribution to Outcomes:

- Strong political influence through intensive mass campaigning and rallies
- Participatory institutional structures and processes in the union and cooperatives
- Use of research to inform advocacy
- Participatory and inclusive approaches
- Support of academic and other institutions

### Overall Sustainability:

KKPKP is supported through membership fees and its member-based economic activities. KKPNSPS is a financial institution that sustains through savings and lending operations. SWaCH sustains through member contributions from the services that they provide through the cooperative. SWaCH also receives some infrastructure and equipment assistance from the PMC.

Source: KKPKP

## 2.3.8 SECONDARY COLLECTION AND TRANSPORTATION

As specified under General Principles (Section 2.3.2 of Part II), secondary storage or collection and transportation is necessary for waste collected from households by smaller vehicles such as carts, tricycles, auto rickshaws, etc.

### 2.3.8.1 CONCEPT OF BIN-LESS AREA OR CITY

Wherever possible, it is advisable to synchronise primary collection and secondary collection, thereby avoiding the need for secondary storage bins or depots.

Segregated waste at the household level is collected by primary collection vehicles, which directly transports this waste to secondary collection vehicles. Secondary collection vehicles are parked daily at specific locations for the entire time during primary collection. Separate

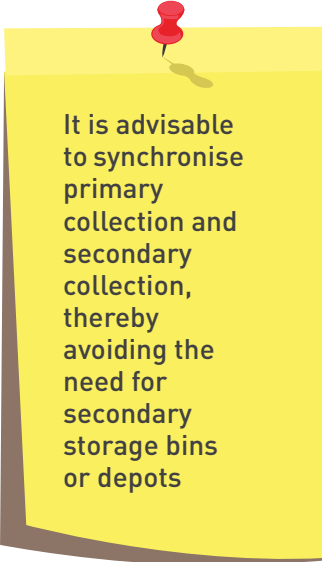

It is advisable to synchronise primary collection and secondary collection, thereby avoiding the need for secondary storage bins or depots



Direct transfer of waste from the primary collection point to secondary collection vehicles promotes a bin-less arrangement for waste collection and transportation. Issues related to placement of bins, littering around bins, non-lifting of bins as per schedule, and continuous movement of fleet to lift bins and replace them are avoided. However, such systems are successful only when there is sufficient fleet of secondary collection vehicles to synchronise with primary collection and where good coordination systems exist. Without adequate management controls, such systems may fail, resulting in littering. It is also advisable to place backup collection bins in commercial or high footfall areas to cater to unexpected waste generation.

Kochi and Nashik Municipal Corporations have successfully implemented bin-less systems in the cities, based on synchronised collection and transportation systems.

vehicles or chambers within a vehicle should be provided to ensure segregated transportation of waste.

### 2.3.8.2 SECONDARY STORAGE

Storage depots are required for secondary collection of waste in cities where the bin-less system is not adopted. In most cities, the following types of waste storage depots exist:

1. Cement-concrete bins
2. Masonry bins
3. Dhalaos
4. Metal bins or containers

Being unhygienic, cement concrete bins, masonry bins, and dhalaos are being replaced by metal containers. In general, waste storage containers should be covered and designed to facilitate mechanical lifting to avoid multiple handling and environmental harm. It is necessary to wash community bins at regular intervals to ensure a healthy and hygienic environment for users and workers. The design of waste storage containers or depots (secondary collection points) should be synchronous with the design of vehicles deployed for both primary and secondary waste collection (Figure 2.12).

Figure 2.12: Synchronised Primary Collection and Secondary Storage<sup>16</sup>



#### Indicative Secondary Storage Systems

- Bins for community places, on public roads and for bulk generators
- 1100 litre capacity four wheeled bins/containers, designed for lifting by compactor
- 3000 to 7000 litre capacity metal containers, designed for lifting by dumper placer system
- Hook lift containers 8 cu.m. or larger (multi-purpose bulk waste containers)

16 Toolkit for Solid Waste Management, Jawaharlal Nehru National Urban Renewal Mission, Ministry of Urban Development, Government of India. <http://jnnurm.nic.in/wp-content/uploads/2012/11/SWM-toolkit.pdf>



## 2.3.8.3 VEHICLES AND EQUIPMENT FOR SECONDARY STORAGE COLLECTION

### 2.3.8.3.1 Bins for Community Places on Public Roads and for Bulk Generators

- Galvanised iron mobile garbage bins ranging from 0.5m<sup>3</sup> to 7m<sup>3</sup> capacity are available. The bins are designed to be lifted or emptied by mechanised container lifting devices such as compactors, dumper placers, etc. They can be used for storage and handling of biodegradable and recyclable waste. They can also be used for secondary storage of street sweeping and silt collected from drains.
- The bins are suitable for bulk waste generators and for placement as community bins at waste storage depots.

### 2.3.8.3.2 Four-wheeled Compactor Containers

- The mobile compactors are designed for transfer points on public roads and places and are especially suitable for biodegradable and recyclable waste.
- The containers are available at 7m<sup>3</sup> to 10m<sup>3</sup>, or larger. They are designed for lifting by universal hook lift system mounted on heavy duty trucks and made for the following purposes:
  - carrying all types of waste in bulk; and
  - depositing debris and biodegradable waste components of MSW (using top loading containers).



#### Use of Stationary Compactors for Improved Secondary Collection and Transportation in Kolkata

**Location:** Kolkata

**Year of Start:** 2012

**Main Players:** Kolkata Municipal Corporation (KMC) and Kolkata Environmental Improvement Project of Asian Development Bank (ADB).

**Approach:** To improve the collection efficiency and transportation system for high volumes of waste generated in densely populated areas in Kolkata City, KMC has piloted the use of stationary compactors for secondary waste collection under the Kolkata Environment Improvement Project of ADB. The stationary compactors, when coupled with hook loaders, provide high transport efficiency for waste. The approaches that were adopted for installation and operationalisation of stationary compactors are detailed below:

- KMC identified 78 sites for installation of stationary compactors.
- KMC procured portable compactors and prime movers (hook loaders) with financial

assistance from Jawaharlal Nehru National Urban Renewal Mission.

- The waste compactors were specifically designed for each site based on the space availability and volume of waste generated in the service area.
- In order to synchronise the system with the existing primary collection system, the portable compactors were installed with a tip cart mechanism. The tip cart mechanism proved to be flexible for manual feeding, wheel barrow feeding, and feeding by small 1–2 m<sup>3</sup> auto tippers.
- KMC provided training and capacity building of the municipal workers for the operation and maintenance of the compactor, as well as orientation for the primary collection workers.



**Stationary Compactor**

**Outcomes:**

- Collection and transportation efficiency of the municipal solid waste system has been improved after the introduction of the stationary compactors.
- Municipal waste is now transported in closed containers that minimise odor and spilling of garbage.
- Open dumping and burning of waste at the secondary collection points have been stopped.
- Portable compactors and prime movers facilitate night transportation of municipal waste.

**Success Factors:**

- There was a strong political will to eradicate open dumping sites in the city.
- Disturbance to the established primary collection system in the areas was minimal.
- Use of static compactors led to increased efficiency of collection and transportation.
- Small space available was optimally used for installation of the compactors with minimal construction at the sites.
- KMC provided adequate training and capacity building for the municipal and primary collection staff.



### Overall Sustainability:

As of 2015, only five stationary compactors have been installed. Funding is required for establishing the entire system. With only 1 year of operation, the overall sustainability of the system is still to be assessed.

Source: KMC

## 2.3.9 CRITERIA FOR SIZING WASTE STORAGE CAPACITIES

Secondary waste storage capacities should be designed to accommodate at least double the expected daily in-flow of waste, that is the storage capacity should be 200% more than the expected daily in-flow of waste.

## 2.3.10 MAINTENANCE OF WASTE STORAGE DEPOTS OR CONTAINERS

ULBs should ensure that secondary storage bins are cleaned at least once in a month and should be painted at least once in a year. Periodic inspection of waste storage depots should be carried out once in three months and any damage caused to the flooring, screen walls, etc. should be repaired.

The metal sheet of the containers might corrode if not well maintained. At a minimum, annual painting of the container from inside and outside must be carried out for increasing the life of containers. Potentially necessary replacements should be provided from stand-by equipment.

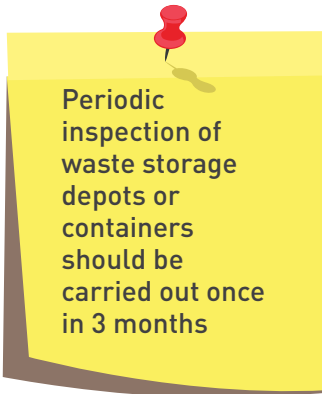

Periodic inspection of waste storage depots or containers should be carried out once in 3 months

### 2.3.10.1 SECONDARY SEGREGATION AND SEGREGATION AT TRANSFER STATIONS

Unsegregated waste, which has not been sorted at primary level, should be segregated either at an intermediate stage (e.g., transfer station) or at the processing plant, prior to treatment, in cases where waste is brought directly to the plant from the waste collection areas. Segregation may be accomplished through manual or mechanised segregation. Multiple handling of waste should be avoided.

## 2.3.11 SECONDARY TRANSPORTATION

### 2.3.11.1 TYPES OF VEHICLES AND EQUIPMENT FOR TRANSPORTATION

Larger capacity vehicles should transport waste from the secondary or tertiary collection point (depot or transfer station) to the processing and treatment facility or landfill. The types of vehicles should synchronise well with containers placed at depots or transfer stations to prevent multiple handling of waste. The selection of the type of vehicles should



### Vehicles Typically Used for Secondary Transportation of Wastes

- Skip truck (dumper placer)
- Refuse collector without compactor
- Rear loading compactor truck (refuse compactor)
- Light commercial vehicle with tipping floor
- Hook loader or hook lifter

reflect the quantity of waste to be transported, travel distance, road widths, road conditions, work shop facilities, etc.

#### 2.3.11.1 Skip Truck (Dumper Placer)

Skip trucks are used for transportation of skips (dumper bins) of different sizes to treatment or disposal sites (Figure 2.13). The usual skip sizes are 2.5m<sup>3</sup>, 3m<sup>3</sup>, 4.5m<sup>3</sup>, and 7m<sup>3</sup>. When a full skip (container) is lifted, an empty skip should be replaced to prevent littering. These are also appropriate vehicles for transportation of inert or construction and demolition (C&D) waste.

- The system should be used to lift waste containers with wastes having densities up to 1,000 kg per m<sup>3</sup>.
- The skip truck should be able to make at least 5–6 trips in an 8-hour shift within a radius of 15 km. Twin dumper placers can also be used to lift twice the number of containers in the given time

Figure 2.13: Skip Truck (Dumper Placer Machines)<sup>17</sup>



17 Ready Reckoner on Municipal Solid Waste Management for Urban Local Bodies, Chennai. Commissionerate of Municipal Administration, 2008. <http://cma.tn.gov.in/cma/en-in/Downloads/Ready%20Reckoner%20on%20Municipal%20Solid%20Waste%20Management%20for%20ULBs.pdf>

### 2.3.11.1.2 Refuse Collector without Compactor

At places with small size containers of 0.5 to 1.1m<sup>3</sup>, the refuse collector vehicle without compactor of 6 to 15m<sup>3</sup> capacity was used in some cities which lifted and unloaded the contents of the small container into the body of the vehicle through a hydraulic system and put the empty container back in place. These are now being replaced by refuse compactors.

### 2.3.11.1.3 Rear Loading Compactor Trucks Used for Transportation

Compactor trucks are used for transportation from smaller transfer points either to larger transfer stations or directly to treatment or disposal sites (Figure 2.14). Compactors can be of different sizes. Some features of the compactor trucks are as follows:

- The loading hopper should be suitable for unloading tipper vehicles and hand held bins, as appropriate for the primary collection.
- Compaction capability to compress garbage or solid waste should be between 800 and 900kg/m<sup>3</sup>.

The three sizes of compactor trucks used in India are:

- small compactors of 5–6m<sup>3</sup> for 4.5–5.5 tonnes of waste per trip;
- medium compactors of 8–10m<sup>3</sup> with a payload capacity of 7–7.5 tonnes of waste per trip; and
- large compactors of 12–16m<sup>3</sup> with a payload capacity of 10–12 tonnes of waste per trip.

Figure 2.14: Medium Size Compactor Truck <sup>18</sup>



18 Source from Manufacturer

**Figure 2.15: Transfer of Waste from Secondary Collection Bins to Refuse Compactor<sup>19</sup>**



#### 2.3.11.1.4 Light Commercial Vehicle with Tipping Floor

Wherever possible, municipal authorities should plan for direct transfer of waste collected from households to secondary collection vehicles (Figure 2.15). In such instances, mini trucks with a tipping floor are appropriate for secondary waste transportation. Door-to-door collectors and sweepers may be directed to transfer waste from primary collection vehicles or handcarts directly to these vehicles.

In small cities with poor repair and maintenance facilities, where high-tech vehicles may not work efficiently, tractor-trolley combination for lifting of containers or towing of containers may be used. Simple hydraulic tipping trailers are recommended to avoid manual unloading at processing plants or disposal sites.

### 2.3.12 WASTE TRANSPORTATION PLANNING AND DEPLOYMENT OF EQUIPMENT AND VEHICLES

Secondary collection and transportation contribute significantly to the cost of MSWM services. Vehicle productivity is the primary indicator of the efficiency of secondary waste collection and transport system. Efficiency may be improved by optimising the collection and transfer operations. Collection routes should be effectively planned to minimise transport distances and ensure an equitable distribution of workload among staff. All the vehicles may be utilised in at least two shifts, depending on waste generation, to lift all containers, ensure full utilisation of the fleet of vehicles, and limit the size of the total fleet. Transportation of waste at night may be done in areas prone to traffic congestion.

To facilitate efficient and cost-effective collection and transportation, ULBs should develop a proper strategy for deployments of collection and transportation vehicles. Table 2.4 and Table 2.5 below show some indicative models of deployment for collection and transportation vehicles for various quantities of MSW. Therefore, during MSWM plan preparation, most suitable solutions need to be tailored according to the local condition. As mentioned, it is important to design the system only on the basis of real data on waste quantities and waste composition.

Routing of secondary collection vehicles should be planned to ensure synchronisation of primary collection, maximise operational efficiency and minimise environmental impacts of transportation. Transportation through environmentally sensitive areas should be avoided

<sup>19</sup> Toolkit for Solid Waste Managementm Jawaharlal Nehru National Urban Renewal Mission, New Delhi, Ministry of Urban Development, Government of India. <http://jnurm.nic.in/wp-content/uploads/2012/11/SWM-toolkit.pdf>

**Table 2.4: Municipal Solid Waste Management Plan for Municipal Councils and A, B, C Class Cities<sup>20,21</sup>**

| APPROXIMATE POPULATION | ULB GENERATING TONNES/DAY         | PRIMARY DOORSTEP SEGREGATED COLLECTION EQUIPMENT AND VEHICLES  | SECONDARY COLLECTION OF STREET WASTE EQUIPMENT AND VEHICLES  | DECENTRALISED OR CENTRALISED PROCESSING, RECOVERING AND RECYCLING  | WASTE DISPOSAL AT COMMUNAL/REGIONAL LANDFILL   |
|------------------------|-----------------------------------|--|--|--|--|
| Up to 50000            | 2.0-2.5 TPD per 10,000 population | Door-to-door collection services through containerised handcarts or tricycles<br>2 bins for storage of wet waste and dry waste<br>10-15 l capacity domestic bins, one of them with lid (as per CIPET specifications)<br>2 community bins of 60 l capacity (20-30 kg) or 120 l capacity (40-60 kg) or 240 l capacity (80-120 kg) or 1.1 m <sup>3</sup> capacity (300-450 kg)<br>Bulk generators at source requires 120 l (49 kg), 240 l (96 kg) bins<br>Contract with private firm, RWA, and NGO, if possible | 3-4 m <sup>3</sup> containers to be placed at the rate of 4 per km <sup>2</sup> area or 1 per 5,000 population<br>Transportation of containers by tractor having container lifting device  | Decentralised processing through composting or biogas technology for both biodegradable and recyclable waste collected from households, shops, etc.<br>If no land is available for decentralised processing, town level processing must be done and direct transfer of waste collected from streets and drains to disposal site through tractors at the rate of 1 tractor per 10,000 population. | Inert only to be transported to common or regional landfill facility                                   |
| 50,000 to 100,000      | 10-30 TPD @ 250 gm/capita/day     | 80% households to be served by covered tractor or covered LCV for door-to-door collection at 1 vehicle per 1,500 households, shops, etc.<br>20% households to be served by tricycles with container for door-to-door collection or handcarts for narrow lanes at 1 tricycle per 200 units<br>Direct transfer of waste from tricycle to tractor or LCV to processing facility   | 100% street sweeping waste to be collected in containerised handcarts and deposited in 3-4 m <sup>3</sup> containers<br>Containers to be placed at 4 per km <sup>2</sup> area or 1 per 5,000 population.<br>Containers to be lifted by tractors or twin bin dumper placers | 50% decentralised processing of waste if suitable space is available<br>If no space, domestic and trade waste to be processed at centralised facility with resource recovery   | Inert only from the processing facility<br>Street sweepings and silt from the drains may be landfilled |

<sup>20</sup> Reference Material on Municipal Waste Management for Urban Local bodies, All India Institute of Local Self Government, 2012 & Manual on Municipal Solid Waste Management, CPHEEO, MoUD, GOI, 2000

<sup>21</sup> Central Institute of Plastics Engineering & Technology

Table 2.5: Municipal Solid Waste Management Plan for Municipal Corporations<sup>22</sup>

| APPROXIMATE POPULATION        | ULB GENERATING TONNES/ DAY | PRIMARY DOORSTEPS SEGREGATED COLLECTION EQUIPMENT AND VEHICLES  | SECONDARY COLLECTION PLACE, EQUIPMENT AND VEHICLES  | DECENTRALISED/CENTRALISED PROCESSING, RECOVERY & RECYCLING   | BULK TRANSPORTATION, LANDFILL DISPOSAL  |
|-------------------------------|----------------------------|---|---|--|---|
| 1,00,000 to 5,00,000          | 25-150 TPD                 | 75% door-to-door collection through covered LCV<br>25% door-to-door collection through containerised tricycles or handcarts from narrow lanes<br>Direct transportation of waste to processing facility if distance is under 5 km, or transportation through compactors if distance of processing facility is longer<br>Compactors to be deployed based on capacity of vehicle and volume or weight of waste | Street sweeping and silt from the drains may be collected in containerised handcarts and taken to secondary storage depot having 1.1–4.0 m <sup>3</sup> metal containers.<br>Containers to be placed at 4 per km <sup>2</sup> area or 1 per 5,000 population.<br>Containers to be lifted by twin bin dumper placers or refuse collector or compactor machines.<br>Dumper placers and compactors based on capacity of vehicle and volume or weight of waste                | 100% door-to-door collected waste to be processed at decentralised sites if available, or processed at one facility<br>Composting, biogas, or RDF facilities may be created. | Inert street sweeping, silt from the drains, and residual waste from processing plants to be landfilled |
| Population between 5–10 lakhs | 150–400 TPD                | 75% door-to-door collection through covered LCV<br>25% door-to-door collection through containerised tricycles or handcarts from narrow lanes<br>Direct transportation of waste to processing facility if distance is under 5 km, or transportation through compactors if distance of processing facility is longer<br>Compactors to be deployed based on capacity of vehicle and volume or weight of waste | Street sweeping and silt from the drains may be collected in containerised handcarts and taken to secondary storage depot having 1.1–4.0 m <sup>3</sup> metal containers.<br>Containers to be placed at 4 per km <sup>2</sup> area or 1 per 5,000 population.<br>Containers to be lifted by twin bin dumper placers or refuse collector or compactor machines.<br>Dumper placers and compactors to be deployed based on capacity of vehicle and volume or weight of waste | 100% door-to-door collected waste to be processed at decentralised sites if available, or processed at one facility<br>Composting, biogas, or RDF facilities may be created. | Inert street sweeping, silt from the drains, and residual waste from processing plants to be landfilled |

22 Reference Material on Municipal Waste Management for Urban Local bodies, All India Institute of Local Self Government (2012).



Table 2.5: Municipal Solid Waste Management Plan for Municipal Corporations [contd.]

| APPROXIMATE POPULATION | ULB GENERATING TONNES/ DAY | PRIMARY DOORSTEPS SEGREGATED COLLECTION EQUIPMENT AND VEHICLES  | SECONDARY COLLECTION PLACE, EQUIPMENT AND VEHICLES  | DECENTRALISED/CENTRALISED PROCESSING, RECOVERY & RECYCLING   | BULK TRANSPORTATION, LANDFILL DISPOSAL  |
|------------------------|----------------------------|---|---|--|---|
| Above 10 lakhs         | 400 TPD & above            | <p>75% door-to-door collection through covered LCV</p> <p>25% door-to-door collection through containerised tricycles or handcarts from narrow lanes</p> <p>Direct transportation of waste to processing facility if distance is under 5 km, or transportation through compactors or transfer stations if distance of processing facility is longer</p> <p>Compactors to be deployed based on capacity of vehicle and volume or weight of waste</p> <p>Large containers of more than 10 t capacity with hook loaders may be deployed at transfer stations for bulk transfer of waste through processing or disposal facility.</p> | <p>Street sweeping and silt from the drains may be collected in containerised handcarts and taken to secondary storage depot having 1.1–4.0 m<sup>3</sup> metal containers</p> <p>Containers to be placed at 4 per km<sup>2</sup> area or 1 per 5,000 population.</p> <p>Containers to be lifted by twin bin dumper placers or refuse collector or compactor machines.</p> <p>Dumper placers and compactors to be deployed based on capacity of vehicle and volume or weight of waste</p> | <p>100% door-to-door collected waste to be processed at decentralised sites if available, or processed at one facility.</p> <p>Composting, biogas, or RDF facilities or waste-to-energy power plants may be installed, as power plants will not be viable if the waste is less than 500 TPD.</p> | <p>Inert street sweepings, silt from the drains, and residual waste from processing plants to be landfilled</p> |

### 2.3.12.1 MANAGEMENT INFORMATION SYSTEM FOR WASTE TRANSPORTATION



Advanced information management, mapping, and communication technologies may be used for efficient MSWM, such as:

- Management Information System (MIS)
- Geographic Information System (GIS)
- Global Positioning System (GPS)
- Radio Frequency Identification (RFID)
- General Packet Radio System (GPRS)

Simple as well as advanced management information systems (MIS)—e.g., geographic information system (GIS), Global Positioning System (GPS), radio frequency identification (RFID), and general packet radio services (GPRS)—are important tools for ULBs to manage MSW in large and mega cities (refer to Section 6.1.3 of Part II). It is essential for the head of the SWM department as well as the head of the ULB to be informed of the day-to-day performance of the SWM service, the service being very vital for maintaining the health and well-being of the people.

As part of the larger MIS, daily reports on some aspects of the MSW transportation system need to be compiled in order to take stock of existing performance and take corrective measures as and when required, such as:

- the number of sanitary workers with their proper roles and responsibilities laid out, daily reporting of supervisors and drivers that are on contractual basis as well as prior substitute arrangements for those absent to avoid backlog of work;
- vehicles and equipment reporting on duty and performing the expected function, number of vehicles off the road on account of breakdown;
- quantity of waste transported, treated, and disposed at the treatment or processing facilities and at landfill; and
- arrangements made or proposed for clearing breakdowns.

Information on the following is required for a basic MIS: (i) waste generation and composition; (ii) staff position and staff requirements; (iii) specific engagement with NGOs, SHGs, community authorities, and other organisations; (iv) recovery of user fees; (v) location of waste storage depots; (vi) number of vehicles, their capacities and types; (vii) number of bins; and (viii) location and capacity of waste processing and disposal sites.

These data coupled with spatial data may be used in GIS software to maintain and manage the waste transportation and processing system. A GPS can be synchronised with the GIS to monitor and track waste transportation vehicles and identify any irregularities in waste movement (refer to Section 6.1.1 and 6.1.2 of Part II).



## Effective Collection and Transportation System to Manage Municipal Solid Waste in Surat

**Year of Start:** 1995 and scaled up in 2007

**Main players:** Surat Municipal Corporation (SMC), PPP contractor, Resident welfare associations.

**Approach:** Surat, the industrial hub and trade capital of Gujarat is one of the fastest growing cities in the state. Owing to its economic importance, the population of Surat continued to grow over the years and increased eight fold in the last four decades. However, the city infrastructure could not keep pace with its population increase leading to inadequate service provision, poor sanitation conditions, unhygienic surroundings thereby impacting public health. This sporadic development and lack of basic services and infrastructure led to an outbreak of plague in the year 1994 claiming many lives. The major cause of the plague was considered to be ineffective management of waste, which led to the blockage of storm water drains resulting in flooding of the fringe areas of the city.

As plague was considered to be a manifestation of the service inabilities related to solid waste and drainage management, the Surat Municipal Corporation assessed the issues and challenges of city administration and carried out major administrative as well as technical reforms for improving the overall system. The following approach was adopted for bringing about significant improvements in the solid waste management system:

- Administrative and financial reforms were carried out along with the rearrangement of the six zones of waste management into 52 sanitary wards for better control of waste collection
- Introduction of centralised complaint redressal system in order to create a responsive waste management system.
- Slum improvement operations were undertaken with the assistance of NGOs.
- Introduction of daily monitoring system for enhancing waste collection and its efficiency.
- Ensuring cleanliness and street sweeping round the clock at nuisance spots.
- Engaging private contractors for collection and transportation of waste to the disposal site, as well as sweeping and scrapping all major streets during the night time.
- Identification and selection of vehicle based on the width of the road and route provided.
- Introduction of Time Place Movement for the collection and transportation system wherein collection vehicles have to move in accordance with the provided time schedule, areas of coverage and number of units.
- Establishment of bulk garbage collection systems for hotels, commercial establishments, slaughterhouses that will collect waste in separate shifts suiting their requirement and timings.
- Massive community meetings were organised by SMC to disseminate the details of the collection system and its functioning.

**Outcome:**

- More than 90% of coverage of SWM services in Surat and collection of waste from the households.
- Timely collection of waste from every household/ shops on daily basis.
- Effective and timely redressal of complaints by the ward supervisors for non-delivery of service.
- Installation of GPS systems on all the vehicles in order to track and improve the collection and transportation efficiency of the vehicles.
- Overall environmental improvement and aesthetic value of the city.
- Skill development and capacity building of the ground staff and contractors engaged in collection of solid waste was undertaken when the system was introduced.

**Success factor:**

- Strategic planning and revisiting/ assessing the existing situation.
- Proactive role of SMC to streamline and monitor the collection and transportation system.
- Capacity building of SMC staff, contractors, vehicle drivers and workers prior to the installation of the system.
- Collection of waste at a stipulated time by the contractors.
- The real time tracking of the vehicles through time place movement chart and GPS systems.
- Intensive campaigning and interaction of officials with citizens regarding the proposed door to door collection system.

**Overall sustainability:**

Collection of user charges has resulted in the financial sustainability of the project. Surat Municipal Corporation has started collecting user charges towards various services like water, sewerage, solid waste and street lighting. It is being collected once in a year along with the property tax bill. The user charges collected through these services meet the O&M cost of the services. The efficiency of tax collection is also more than 90%. Apart from this, there is a well-defined system of collection of administration charges towards various offences like littering garbage, absence of garbage collection bins, open burning etc.

*Source: SMC*

### **2.3.12.2 MANAGEMENT OF CONTRACTS FOR WASTE COLLECTION AND TRANSPORTATION**

Municipal authorities might involve private sector to ensure efficient service delivery and to bring in expertise and finances that may not be available with the ULB. Collection and transportation of waste can be entrusted to a private contractor partly or fully. It is essential to identify the exact services to be rendered through private sector participation. This can be done by determining the (i) number of households, shops, and establishments to be served; (ii) frequency of service; (iii) time of service delivery; (iv) type and level of service; (v) type and capacity of vehicles to be used; and (vi) distance from service area to transfer station or processing and disposal site. It is also essential to set up a mechanism for measuring the performance of the contractors and decide the mode of payment.

The contractor should keep all vehicles and equipment deployed for performing the services in good working conditions. The contractor must also ensure efficient, inclusive, and fair treatment of its workers, keeping in view the health and safety aspects in conformity with national and international guidelines and standards. Specific requirements for women workers, such as provision of crèches (day care centres) and linkages to anganwadis (courtyard shelter) in the nearby community, should be encouraged.

It is necessary to develop a proper contract management and monitoring system before contracting private firms (for details, refer to Section 5.3 of Part II).

## **2.4 STREET CLEANING**

Street cleaning is a fundamental service ensuring clean and hygienic urban conditions. Generally, households, commercial entities, and transport operators should be made responsible for garbage minimisation on the streets. Street wastes include paper, plastics, dirt, leaves, and other vegetative matters. Manual sweeping is commonly practiced in India, as many streets are congested and narrow. Inefficient waste collection systems coupled with public littering significantly contribute to waste piles on the streets.

A wide variety of tools, equipment, and methods (both manual and mechanical) are available for street sweeping. Through the introduction of efficient methods of combining manual and mechanical sweeping, municipal authorities can achieve significant savings.

## 2.4.1 SOLID WASTE MANAGEMENT RULES, 2016 - REQUIREMENTS ON STREET CLEANING

As per SWM Rules, 2016:



Clause 15: Duties and responsibilities of local authorities:-

- (k) direct street sweepers not to burn tree leaves collected from street sweeping and store them separately and handover to the waste collectors or agency authorised by local body;
- (n) collect separately waste from sweeping of streets, lanes and by-lanes daily, or on alternate days or twice a week depending on the density of population, commercial activity and local situation;
- (o) set up covered secondary storage facility for temporary storage of street sweepings and silt removed from surface drains in cases where direct collection of such waste into transport vehicles is not convenient. Waste so collected shall be collected and disposed of at regular intervals as decided by the local body;

Manual handling of wastes is prohibited. However, if unavoidable due to constraints, manual handling should be carried out under proper precautions with due care for health and safety of workers. Workers should be provided with protective gear such as uniforms, shoes, gloves and other implements etc., for their safe and easy working. They should be subjected to periodic health checks and should be provided with social security benefits including health insurance.

## 2.4.2 PLANNING FOR STREET CLEANING

It is necessary to have a well-planned, time-bound daily system for street sweeping including adequate staffing and equipment. Street sweepers should be instructed to report daily for duty at a designated location, which could be the nearest municipal ward office or an office space identified by the commissioned contractor. However, it should be ensured that such location will have a provision for storing street sweeping equipment. The location may also serve as an office for the supervisor. Table 2.6 below shows some important aspects for the planning of street cleaning and Table 2.7 gives the different areas in a city and their required cleaning frequencies and scheduling.

Both manual and mechanical street cleaning are possible. However, manual street cleaning is preferred in narrow, congested streets and in streets where the road carpeting is damaged

**Table 2.6: Street Sweeping Norms for Small towns or Small Cities or Mega Cities<sup>23</sup>**

| <b>PLANNING FOR STREET SWEEPING</b>     |   |  |   |
|---|---|--|---|
|   | Small town  | Medium City  | Mega city   |
| Equipment                               | <ul style="list-style-type: none"> <li>• Long handled broom</li> <li>• Metal tray and metal plate</li> <li>• Containerised handcart or tricycle</li> <li>• Tractor with covered trolley</li> <li>• Container lifting device</li> </ul>  | <ul style="list-style-type: none"> <li>• Long handled broom</li> <li>• Metal tray and metal plate</li> <li>• Containerised handcart or tricycle</li> <li>• Secondary storage bin</li> <li>• Dumper placer or compactor</li> <li>• Mechanical street sweeper</li> <li>• Container lifting device</li> </ul> | <ul style="list-style-type: none"> <li>• Long handled broom</li> <li>• Metal tray and metal plate</li> <li>• Containerised handcart or tricycle</li> <li>• Secondary storage bins</li> <li>• Dumper placer or compactor</li> <li>• Container lifting device</li> <li>• Mechanical street sweeper</li> </ul> |
| Staff requirement based on road density | <ul style="list-style-type: none"> <li>• High density roads: 1 person per 300–350 running meters of road length</li> <li>• Medium density roads: 1 person per 500 running meters of road length</li> <li>• Low density roads: 1 person per 750–1,000 meters of road length</li> </ul> | <ul style="list-style-type: none"> <li>• High density roads: 1 person per 300–350 running meters of road length</li> <li>• Medium density roads: 1 person per 500 running meters of road length</li> <li>• Low density roads: 1 person per 750–1,000 meters of road length</li> </ul>                      | <ul style="list-style-type: none"> <li>• High density roads: 1 person per 300–350 running meters road length</li> <li>• Medium density roads: 1 person per 500 running meters of road length</li> <li>• Low density roads: 1 person per 750–1,000 meters of road length</li> </ul>                          |

### 2.4.2.1 STREET CLASSIFICATION AND STREET CLEANING FREQUENCY

Streets are classified based on their location, traffic intensity, type of street surface, character of area (e.g., commercial or residential), etc. Based on street classification, the frequency of service for street sweeping may be determined (Table 2.7).

<sup>23</sup> Manual on Municipal Solid Waste Management (First Edition), Central Public Health and Environmental Engineering Organisation (CPHEEO), 2000, Ministry of Urban Development.

**Table 2.7: Typical Classification of Streets and Frequency of Sweeping<sup>24</sup>**

| CLASS | CHARACTER OF STREET  | FREQUENCY OF SWEEPING  |
|-------|--|--|
| A     | City centre – shopping areas   | Daily or twice, depending on need                                      |
| B     | Market areas   | Daily  |
| C     | Minor streets  | Daily  |
| D     | Sub-urban shopping streets   | Daily  |
| E     | Residential streets  | Daily  |
| F     | Roads and streets having no households or establishments on either sides | Once a week  |
| G     | Highways   | Rarely necessary to sweep highways as motor traffic creates turbulence |
| H     | Suburban main streets  | Twice a week   |
| I     | Open spaces  | Occasionally, when required (minimum once in 2 weeks)                  |

Planning an effective street sweeping system requires classification of streets, according to the required frequency of sweeping. The classification may be based on location, traffic intensity, type of street surface, character of area (e.g. commercial or residential), etc.

In cities and towns where doorstep collection of waste is ensured, the frequency of road sweeping can be reduced, especially in low-density and low-traffic areas

ULBs should adjust the frequency of street cleaning based on local conditions. Also, the time of street cleaning should be carefully defined to avoid conflicts with traffic, parked vehicles, and pedestrians. The service should be carried out preferably during hours of less activities in the streets, e.g., early morning and at night. Night time service is only advisable on well-lit main or commercial roads, mainly because street cleaning activities can disturb residents and could be potentially dangerous, especially for women workers. ULBs should ensure the safety of all workers at night by providing them with appropriate personal protective equipment (PPE). Should women be engaged, sufficient protection is to be provided to ensure that they are not harassed by strangers, police or law enforcers, or other members of the community. Workers should also be provided with proper uniforms with definite colour code, which have reflectors (for the night work), along with ID cards. This would ensure that workers are recognised and have proper access to protection officers or police if required. Constant checking and regulatory mechanisms should be put in place to ensure that all workers are safe from all forms of harassments, dangers, and accidents. Adequate protection should be afforded to women working at night through deployment of constables or patrol teams who should be informed of how many women at any given time would be engaged in work on particular streets.

Street sweeping in residential areas may be carried out in two spells—5 hours in the morning and 3–4 hours in the afternoon. Staff involved in street sweeping should also be responsible for cleaning drains (up to 18 inches depth), along the same “beat.” Multiple handling of wastes should be avoided. The local sanitary inspector should be responsible for inspecting and maintaining records on the extent of service provision.

<sup>24</sup> Manual on Municipal Solid Waste Management (First Edition), Central Public Health and Environmental Engineering Organisation (CPHEEO), 2000, Ministry of Urban Development.





ULBs can adopt different strategies for tourist places, where many people are present almost at all hours. In such places, regular cleaning throughout the day (2–3 times) and during weekends and national holidays may be necessary.

### 2.4.3 MANUAL STREET CLEANING

Manual cleaning involves sweeping and collection of waste by sanitation workers from streets, roads, lanes, by-lanes, and public places. Street sweeping normally includes cleaning the road surface and footpaths on both sides of the road. All waste from street sweeping should be transported separately without mixing with domestic or any other commercial establishment waste. This is to ensure efficient waste processing and to avoid mixing of inert with other waste, thereby minimising the burden of segregation and facilitating efficient waste processing.

Ideally, street sweepings and silt collected from drains should be transferred from the wheel barrows to a designated black storage bin or container placed at the waste storage depot. Depending on the type of road and activity on the road, the size of the bins may be decided. These bins should be regularly lifted by municipal authorities before bins start overflowing and taken to waste processing facility for further processing (sand recovery facility, if available) and reuse or for disposal at the landfill site.

#### 2.4.3.1 TYPE OF STREET CLEANING EQUIPMENTS

Use of appropriate tools plays an important role in improving work efficiency. Equipment for manual sweeping should be relatively light and easy to handle for both men and women to ensure that workers do not expend disproportionate energy in wielding such equipment. Local authorities should apply modern technology where appropriate and should also organise training and capacity building programmes for their staff.

Commonly used equipment for street cleaning are the following.

**Long handled brooms:** They cause less strain and support correct posture. An adequate type uses bunches of filaments inserted into a wooden stick. The length of the broom should be such that the male and female workforce can use it comfortably, without bending. The handle should not be heavy. The filaments should be tightly spaced to facilitate easy collection of fine silt and dust, leading to efficient cleaning of streets. There are two types of long handled filamentous broom used by municipal staff in India (Figure 2.16).

Brooms with sufficiently long handles allow for easy removal of street sweepings and dust

- **Fan-shaped filament broom:** The filaments of the broom fan out, removing litter from the streets but leaving behind sand and silt.
- **Bunched filament broom:** The filaments are bunched together to facilitate removal of litter, sand and silt from the streets.

Figure 2.16: Fan-shaped and Bunched Filament Brooms (Delhi Model)



A typical long handled filament broom may consist of the following specification (as per Delhi model):

- Length of the broom: 80–85 cm
- Weight of the broom: 1kg
- Binding material: 20 gauge MS sheet ring having width of 1.5–2.0 cm
- Handle of the broom: bamboo of 135 cm length, 3–4 cm diameter
- Weight of the bamboo handle: 900g (approximately)

**Shovels:** Heaps of street wastes gathered by brooms have to be picked up and placed in a container. The conventional tool for this purpose is a large straight-blade shovel or metal plate and metal tray. However, when the waste comprise large quantities of light materials such as leaves, a shovel is ineffective because dried leaves fall off or are blown away during transfer. A solution is a pair of flat boards, usually plywood, between which the waste is retained by hand-pressure.

**Handcarts:** Handcarts facilitate transportation of street waste. Handcarts should have four to six detachable plastic containers with a capacity of 25–40 l each to allow easy transferring of waste into community waste storage bins. It must have sealed ball bearings and handles having a crossbar up to navel height, and its wheels should have rubber strips or tyres for ease of handling and minimising fatigue.

## 2.4.4 MECHANISED STREET CLEANING

Generally, mechanised street cleaning equipment have a driving unit attached with brushes for dislodging sticking material. They may also be equipped with a water tank and sprayers to loosen particles and reduce dust. A vacuum system or conveyor system transfers waste from the street to the storage receptacle. There is a wide range of mechanised street cleaners available in the market. Equipment should be chosen carefully, taking into account the street conditions and needs of the city, reliability, ease of procurement of spare parts, investment cost, and operation and maintenance costs.

### 2.4.4.1 MECHANICAL BROOM SWEEPER

A mechanical broom sweeper (Figure 2.17) is designed to remove standard road waste, using various kinds of circulating brushes that sweep material onto a conveyer belt and then into bins. Mechanical broom sweepers use a gutter broom which displaces debris from the curb into the path of the main broom, which is attached to a conveyer belt. Mechanical broom sweepers have an ability to pick up large debris such as plastic bottles, cans, wet vegetation, gravel, and coarse sand. They are also effective in removing packed dirt from roadways. However, they are ineffective in picking up fine material.

Mechanical broom sweepers have lower energy demand than regenerative sweepers and vacuum sweepers. Gender stereotyping associated with driving should be avoided; women should also be encouraged to drive and provided with training.

The lower powered mechanical broom sweepers are more suitable for large, flat, paved surfaces like shop floors, industrial floors, etc.



ULBs should make well-informed decisions while choosing mechanical sweepers and should consider local conditions, investment cost, and operation and maintenance costs

Figure 2.17: Mechanical Broom Sweeper<sup>25</sup>

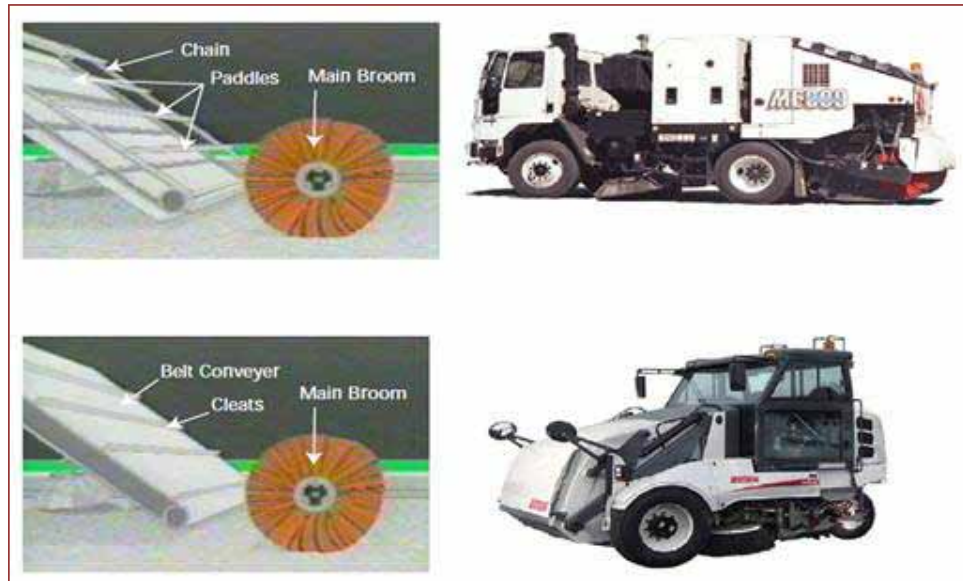

#### 2.4.4.2 REGENERATIVE AIR SWEEPER

The regenerative air sweeper (Figure 2.18) uses a broom to collect large debris or waste. It also uses forced air and high power vacuum for the collection of fine material. It blows high pressure air onto the road to loosen very fine sediment. A vacuum suction lifts all particles and captures them in a hopper. Regenerative air sweepers can remove fine sand and dust, provided the surface is dry. They contribute to preventing air pollution by capturing fine sand particles. They have relatively higher energy consumption compared with the mechanical broom sweeper, and are quite expensive. However, they can clean a wider path and limit the amount of dust-laden air that is exhausted back into the atmosphere. They are also able to pick up large debris, since the blast of air is able to dislodge material and get them into the airflow stream that is created by the suction. But regenerative air sweepers are more productive on flat roads, and their performance may not be satisfactory for most of the Indian roads. Such machines need the requisite power to create an effective vacuum environment which is also facilitated when the surface it operates upon is relatively flat and there are no unpaved shoulders along the road. Also, potholes need to be repaired promptly to enable smooth working.

<sup>25</sup> Resource for Implementing a Street Sweeping Best Practice, Local Road Research Board, Department of Transportation, Minnesota, 2008.

Figure 2.18: Regenerative Air Sweeper<sup>26</sup>



### 2.4.4.3 VACUUM SWEEPER

A vacuum sweeper (power sweeper machine) uses a broom to move debris towards the vacuum nozzle. Typically, there is a suction inlet on one side of the sweeping head, and the “used” air is constantly exhausted during the sweeping process (Figure 2.19). There are various types of vacuum sweepers based on the location of the vacuum nozzle. Vacuum sweepers utilise a fan that exhausts air directly to the atmosphere and uses water for dust suppression. They can vacuum material from channels and gutters and collect fine particles from within cracks, but cannot pick up large debris like tree trimmings and disposed packaging. However, since there is no vacuum suction beneath the broom, the area of the road under the broom may still retain fine material. Even though vacuum sweepers use water-based dust suppression systems, they exhaust a high level of particulates into the atmosphere on a continuous basis.

Figure 2.19: Vacuum Sweeper and Vacuum Nozzle<sup>27</sup>



There are two types of vacuum sweepers available in the Indian market:

- **Chassis mounted:** The power sweeping unit with container is mounted on a vehicular chassis with hydraulic motors and power controls for driving brushes, suction unit, and jet washing, with auxiliary engine

26 Ibid.

27 Ibid.

carrying out these functions, whereas the automobile chassis engine drives the vehicle. The payload capacity of power sweeping machines is approximately 4,000–5,000 kg with a 4–6 m<sup>3</sup> stainless steel or higher grade container for storage of sweeping wastes.

- **Self-propelled:** The self-driven power sweeping machine (Figure 2.20) is a composite vehicle with a container, hydraulic motor, and power controls for driving brushes, suction unit, and jet washing. The payload capacity ranges from 2,000–3,000 kg in a container of 1.75–2.50 m<sup>3</sup>. This is relatively a small machine which can be deployed on both narrow and wide roads. Two side brushes throw dust towards a main or inner broom which finally transports dust into a central hopper.

Mechanised sweepers with a capacity of 1.85 m<sup>3</sup> and three front brushes are capable of working at two levels and can be used to clean footpaths as well. An attached vacuum wander hose can collect heavy material. An attached sprinkling bar can be used for washing streets.

Figure 2.20: Self-propelled road sweeping machine<sup>28</sup>



The following operational conditions should be considered for mechanised street sweeping:

- It is essential to work mechanised sweepers in two shifts minimum to ensure economic viability.
- One skilled operator and one semi-skilled cooperater are required to operate a mechanised sweeper.

28 Source taken from Manufacturer

- Given that the machine will not be able to clean all odd and uneven places, an additional group of four manual sweepers may also need to be deployed with every power sweeper.
- Typical fuel efficiency of a mechanised sweeper is 1.5–2.0 km per l and lower, if road conditions are not conducive or in places of heavy littering.
- All brushes are to be replaced or refurbished after nearly every 1,000 km of sweeping operations (7–10 days actual operations in two shifts).

Collected sweeping is to be unloaded into containers and transported to the disposal place in a separate vehicle other than the mechanical sweeper.

#### 2.4.4.4 FINANCIAL IMPLICATIONS OF MECHANISED STREET CLEANING

The total cost of mechanised street cleaning or sweeping includes the purchase cost of the machine, annual cost of operation and maintenance, cost of disposing the debris, and wages of the driver and helper. It is also necessary to consider efficiency, average life, and availability of spare parts and the presence of authorised garages for maintenance of the machine before buying the product, so that improvement in street cleaning services would not result in unexpected costs.



##### **For Assisting the ULBs in Selection of an Appropriate Power Sweeper**

The selection of the type of sweeper will depend on specific conditions of roads targeted for sweeping. In general, mechanical sweepers are more effective at picking up large debris and cleaning wet streets and have lower capital and operating costs. However, mechanical sweepers can create large amounts of airborne dust. Vacuum-assisted and regenerative air sweepers are more effective in removing fine particles and associated heavy metals but tend to be ineffective for cleaning wet streets. They are effective in areas where respirable particulate matter is a cause of concern. They may also be noisier than mechanical sweepers.

Compared to mechanical broom sweepers and air regenerative sweepers, vacuum sweepers are more effective but also more expensive. However, given their high performance rate in comparison with the other two options, vacuum sweepers yield substantially better cost efficiency in most cases.

#### 2.4.5 CLEANING OF SURFACE DRAINS

In many cities there are open surface drains along the roadside, which needs to be cleaned regularly to permit free flow of storm water or grey water. MSWM authorities should ensure through campaigning, statutory regulations, and monetary fines that citizens and sweepers

In order to ensure that sweepers do not dispose waste into drains, same staff that is responsible for cleaning street should be made responsible for cleaning adjacent drains as well

do not dispose waste into drains. A further approach to prevent this is to make the same staff responsible for cleaning streets as well as adjacent drains up to a depth of 45–60 cm. The solid waste dumped in storm drains should be collected by drain cleaners and disposed off, along with drain cleaning and street sweeping material, in a municipal sanitary landfill because of a high possibility of contamination.

The staff requirement for drain cleaning depends on the length of drain. As a general rule, one person can clean up to 500 m of a shallow surface drain (not more than 45–60 cm) per day. This could be adjusted based on local conditions. Tools which meet proper safety standards for waste transfer, such as safety equipment and vehicles, should be given to the drain cleaners. Generally, light shovels and handcarts are required for drain cleaning. The equipment for surface drain cleaning does not differ much from the street cleaning equipment.

The removal of silt from surface drains or storm water drains deeper than 60 cm and manholes should be done by the engineering division of the local authority. It is advisable to explore new technologies like suction pumps loaded onto trucks (Figure 2.21) for removal of silt from manholes to avoid manual scavenging.

**Figure 2.21: Truck Mounted with Pressure Water Jetting and Suction Machine<sup>29</sup>**



### 2.4.5.1 SILT MANAGEMENT



Clause 15: Duties and responsibilities of local authorities:-

(n) collect separately waste from sweeping of streets, lanes and by-lanes daily, or on alternate days or twice a week depending on the density

29 Bhopal Municipal Corporation





of population, commercial activity and local situation;

- (o) set up covered secondary storage facility for temporary storage of street sweepings and silt removed from surface drains in cases where direct collection of such waste into transport vehicles is not convenient. Waste so collected shall be collected and disposed of at regular intervals as decided by the local body;

If the street sweepings contain biodegradable or recyclable waste, such waste shall be segregated and sent to respective processing facility”. The silt collected from surface drains should not be allowed to stay on open roads or footpaths beyond 4 hours. Wet silt should be removed from the main roads in less than 4 hours and, in other areas, within 24 hours and should be directly transported to the landfill or be disposed at the waste storage depots in the black container to prevent nuisance and health hazards. This waste is not amenable for composting given the possibility of high contaminants and inert content in the silt.

Silt removed from surface drains and stored on the side of the drain should be collected as soon as possible and transported directly to the landfill

## 2.4.6 TRANSFER STATIONS

In large cities where disposal sites are more than 15 km away from the collection area, it is economical to set up transfer stations as tertiary storage depots to save transportation time and fuel. The transfer station or tertiary storage depot can also be equipped with a material recovery facility, where recyclables are sorted and sent for further processing or to recyclable markets. Transfer stations usually consist of large containers of about 15–25 m<sup>3</sup>. A ramp facility can be provided to facilitate unloading of vehicles or dumper placer containers directly into large vehicles or containers kept at a lower level just below the ramp. The transfer station can also have the facility of a hopper, into which waste can be transferred, and then with the help of a static compactor, waste can be pushed into the large hauling vehicle or container.

Transfer stations should be set up in large cities where disposal sites are more than 15 km away to save on transportation time and fuel

Transfer stations are usually part of the waste management system in large cities like Delhi, Mumbai, Bengaluru, Kolkata, Ahmedabad, Coimbatore, Chennai, etc. The smaller municipal authorities should consider setting up simple transfer stations having a ramp facility for transfer of waste from a small vehicle or container to a large hauling vehicle. Only large cities should consider setting up large transfer stations to handle over 300 tonnes per day (TPD) of waste using static compactor facilities.

Consideration for setting up of transfer station:

- Small ULBs- simple transfer stations with a ramp facility
- Large ULBs- transfer stations to handle at least 300 TPD using static compactor facilities



### General Rule of Thumb

- If the one-way travel distance to disposal is over 15 km or over 30 minutes, the need for transfer stations should be assessed.
- Transfer stations should be made only when the cost of direct haul in collection vehicles would outweigh the cost of supplemental haul in large bulk-haul transfer vehicles plus the cost of the supporting transfer system infrastructure at the transfer station and disposal site.

### 2.4.6.1 TYPES OF TRANSFER STATIONS

Waste is unloaded at a transfer station either directly into tertiary transport vehicles (direct unloading) or into a storage area.<sup>30</sup>

**Direct Unloading:** A direct unloading system involves a two-level arrangement, wherein the collection vehicles drive up a ramp to the upper level to discharge the waste into a transfer vehicle parked onsite or loading system as depicted in Figure 2.22.

Direct unloading systems require limited civil works and stationary equipment facilities, and are thus low-cost solutions for implementation and operation. However, the direct unloading system requires the availability of transfer vehicles at the transfer station to keep pace with the arrival of collection vehicles, so that no delays are caused in the collection operations. The direct unloading system is usually implemented only as a small-scale system, i.e., typically where the quantity of waste handled is less than 300 TPD. In most cities, collection vehicles arrive at the transfer station within 1 or 2 peak hours per shift. The size of the transfer fleet in a direct unloading system would have to meet these peak hour demands.

Figure 2.22: Direct Transfer Station<sup>31</sup>

In case of large-scale transfer station, discharge hoppers and transfer vehicles should be provided to make sure that collection trucks are never kept waiting

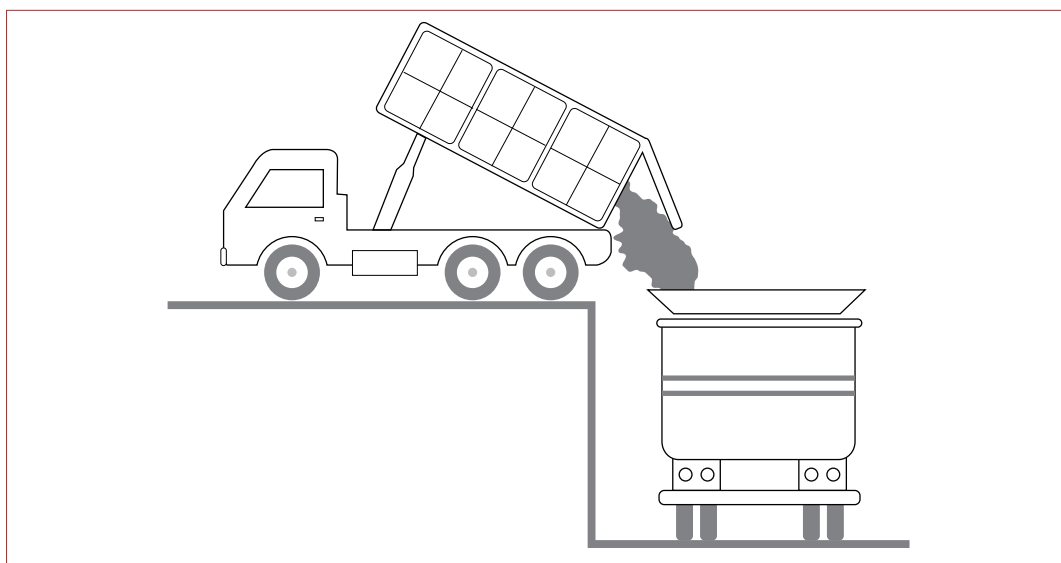

**Unloading-to-Storage:** An unloading-to-storage system involves collection vehicles discharging into a storage area. From the storage area, wastes are subsequently loaded into transfer vehicles. The storage area may be a platform on the same level as the unloading level, in which case only a two-level arrangement is required. The storage area may be

30 Transfer Station Design Concepts for Developing Countries [online]. Cointreau, S., (n.d). Available at: <http://siteresources.worldbank.org/INTUSWM/Resources/463617-1202332338898/transferdesignoptions.pdf>

31 Toolkit for Solid Waste Management, Jawaharlal Nehru National Urban Renewal Mission, Ministry of Urban Development, Government of India. <http://jnurm.nic.in/wp-content/uploads/2012/11/SWM-toolkit.pdf>

a pit, below the level of the unloading level or above the level on which the transfer vehicle is parked, in which case a three-level arrangement is required. The storage area is commonly designed to hold the peak quantity of waste generated in 1 day.

In the unloading-to-storage system, waste unloaded to a storage platform is pushed by a bulldozer (or wheeled loader) into a hopper or onto a conveyor. Waste unloaded to a storage pit is picked up by an overhead crane or pushed by a bulldozer to the receiving hopper. The crane or bulldozer operator visually inspects the waste during operation to set aside any waste which is potentially hazardous or could damage the transfer vehicle during loading (Figure 2.23 and Figure 2.24).

**Figure 2.23: Stationary Compactor Transfer Station Design**

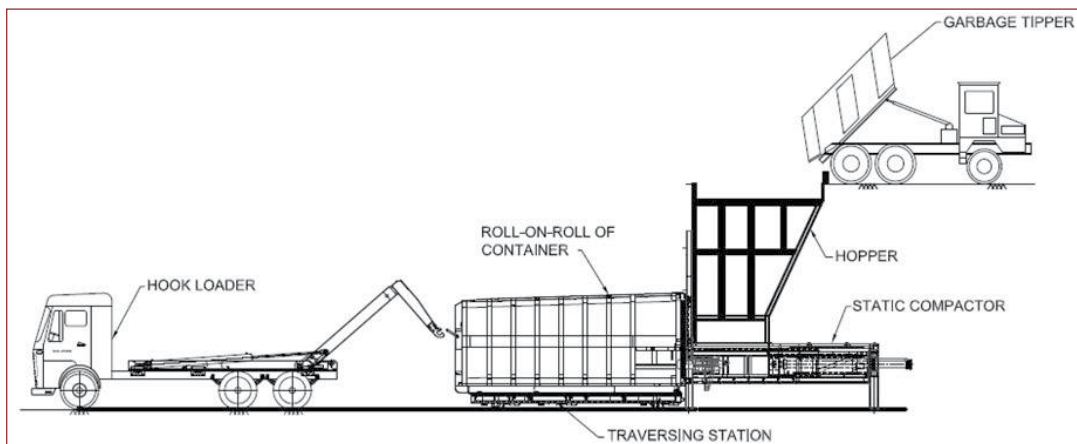

**Figure 2.24: Typical activities at the Transfer Station<sup>32</sup>**



32 Taken from Municipal Corporation of Faridabad



### Modern Waste Transfer Stations in Coimbatore

Modern municipal solid waste transfer stations are located in cities like Coimbatore and Surat. Coimbatore City has three modern transfer stations at Peelamedu, Sathy Road, and Ukkadam. All transfer stations have facilities to quickly unload the waste, compact it, and transfer it to the waste processing facilities. The transfer station has a split level building with a high roof suitable for monsoon operations. Waste is brought to the transfer station for loading into larger containers. These transfer stations are designed based on local conditions, with an aim to achieve maximum utilisation of space and, most importantly, to ensure a quick turnover of unloading and loading of waste.

The transfer station includes several equipment, such as heavy-duty high compaction compactor, hopper, charge box, load on loaders, and a trailer-type hook loader with a container of 20 cubic meters (m<sup>3</sup>). The system is designed to process 200 tons (t) of compacted waste per day.

#### Transfer Station Capacity and Waste Loading Bay Arrangement

These transfer stations are initially designed for 200 tons per day (TPD) waste handling capacity. For these transfer stations, one stationary compactor with 35 tons per hour (TPH) throughput is provided initially. An additional bay to house a similar compactor for future augmentation will be provided. In addition, an additional bay without stationary compactor for loading the waste into open-at-top containers by direct deposition is provided. Each transfer station is able to handle more than 200 TPD of waste. The working shift coincides with the arrival of waste from 7 a.m. to 3 p.m. (varies as per the required condition).

As the waste quantity increases in peak hours, waste is directly loaded into open containers to match the increased waste quantity. The transfer station is at all times able to load the open containers without compaction. The advantage of this arrangement is that during downtime of the stationary compactor, the transfer station operations are able to continue without any disruption.

To facilitate unloading operations on the floor, a separate area with enough space for 1 hour storage, with a waste height of 0.5 m for peak hour waste arrivals (30 TPH), is provided on the upper deck portion of the transfer station. This facility, however, is used only under exceptional conditions.

#### Salient Features of a Transfer Station (Sathy Road)

|  |                     |
|--|---------------------|
| • Area of the site:  | 1.55 acres          |
| • Designed capacity:                                       | 200 TPD             |
| • Number of stationary compactor:                          | 1                   |
| • Capacity of charge box or hopper:                        | 3.34 m <sup>3</sup> |
| • Round distance from transfer station to disposal site:   | 34 km               |
| • Waste handled during peak hour (6:30 a.m. to 9:30 a.m.): | 70 t                |
| • System capacity:   | 35 TPH              |
| • Capacity of computerised weigh bridge:                   | 40 t                |

### Site before commencement of work



### Site after commencement of work



Source: Coimbatore City Municipal Corporation

## 2.5 ACTION POINTS FOR AWARENESS GENERATION THROUGH INFORMATION, EDUCATION, AND COMMUNICATION ACTIVITIES FOR EFFICIENT SEGREGATION, COLLECTION AND TRANSPORTATION

As mentioned, SWM Rules, 2016 mandates ULBs to create public awareness through information, education, and communication (IEC) campaign to educate the waste generators on MSWM activities. Some of the action points for awareness generation are the following:

- Ensure active participation of the community in reducing overall quantities of waste. The different waste reduction strategies, such as take-back, deposit–refund system, etc. will be successful only if the community is ready to adopt the change.
- Promote source reduction programmes in the community and encourage handover of recyclable material to sustainable recycling facilities through informal sector, NGOs, CBOs, etc.
- Campaign for reducing the use of specific non-recyclable, non-reusable, or toxic material. Practice and promote material substitution where possible.
- Generate awareness among people to avoid littering.
- Sensitise citizens to segregate waste at their premises into biodegradable, dry, and special waste and hand over the segregated waste to the collectors. Involvement of RWAs, CBOs, NGOs, SHGs, and market associations is imperative to ensure the success of source segregation.
- Ensure awareness on existing recyclable collection systems, including dedicated collection points. Enforce extended producer responsibility (EPR) initiatives.
- Hold regular meetings among the ULB staff and representatives of RWAs, market associations, NGOs, SHGs, and other stakeholders to ensure successful uptake of such programs.
- Ensure active participation of the community for successful implementation of primary and secondary collection systems.
- Involve community in designing the primary collection system, e.g., in determining waste collection system and timings.
- Generate awareness on bye-laws on waste collection and management system as well as user charges levied on different waste fractions.

# **Technical Aspects** of Processing and Treatment of Municipal Solid Waste

## IN THIS SECTION

|     |  |     |
|-----|--|-----|
| 3.1 | Recycling and Recovery   | 210 |
| 3.2 | Composting   | 229 |
| 3.3 | Waste to Energy  | 276 |
| 3.4 | Biomethanation   | 295 |
| 3.5 | Refuse Derived Fuel  | 308 |
| 3.6 | Technologies under Development   | 319 |
| 3.7 | Construction and Demolition Waste (C&D WASTE)  | 329 |
| 3.8 | Action Points for Awareness Generation Through Information, Education, and Communication Activities for Technical Aspects of Processing and Treatment of Municipal Solid Waste | 247 |



### 3. TECHNICAL ASPECTS OF PROCESSING AND TREATMENT OF MUNICIPAL SOLID WASTE

Municipal solid waste management (MSWM) and adoption of processing technologies depend largely on the quantity and characteristics of the total waste generated in an urban local body (ULB). A prerequisite for overall project implementation is the availability of the financial resources and in-house capacity of local authorities.

Integrated solid waste management (ISWM), as discussed Section 1.2 of Part II, is a strategic approach to manage municipal solid waste (MSW) in a sustainable manner by considering all aspects of MSWM, namely generation, segregation, transfer, sorting, treatment, recovery, and disposal in an integrated manner, with an emphasis on maximising resource use efficiency.

The least preferred option of ISWM is disposal of waste in landfills, where no landfill gas capture is planned. Normally, landfills that integrate the capture and use of methane are preferred over landfills that flare landfill gas.

However, Indian laws and rules do not permit disposal of organic matter into sanitary landfills and mandate that only inert rejects (residual waste) from processing facilities, inert street sweepings, etc. can be landfilled. In cases where old dumps are to be closed, there is a possibility of capturing methane gas for further use, which may be explored. However, repeated burning of the waste significantly decreases the potential of capturing methane.

Figure 3.1: Integrated Solid Waste Management Hierarchy<sup>1</sup>

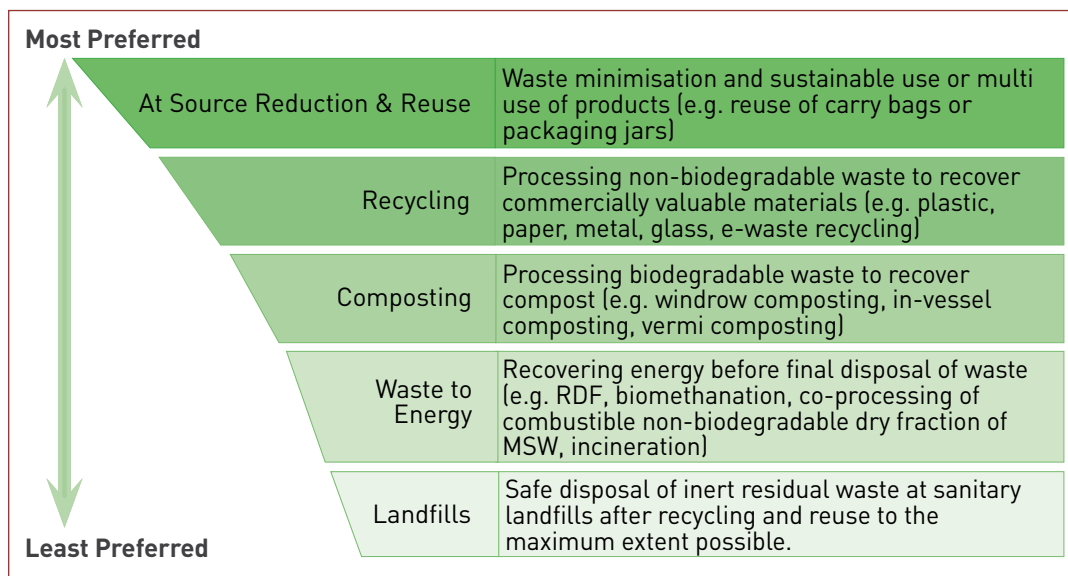

The ISWM hierarchy ranks waste management strategies according to their environmental benefits

<sup>1</sup> Developed by the Expert Committee for revision of MSWM manual (2013-15).



The sections below elaborate on MSWM processing technologies and disposal options in the order as specified by the ISWM hierarchy. And as mentioned, waste minimisation should be the prime objective of any waste management system in ULBs.

### 3.1 RECYCLING AND RECOVERY

Preferential order of waste management options as per the ISWM hierarchy:

- At Source Reduction and Reuse
- Recycling
- Composting
- Waste to Energy
- Landfills

Solid Waste Management (SWM) Rules, 2016 defines recycling as “the process of transforming segregated solid waste into a new product or a raw material for producing new products.” Further, it also states that “arrangement shall be made to provide segregated recyclable material to the recycling industry through waste pickers or any other agency engaged or authorised by the urban local body for the purpose.”

According to the ISWM hierarchy, recycling is a preferred waste management strategy after source reduction and reuse. Recycling systems should be adopted before planning for any waste processing or treatment facilities. Figure 3.2 indicates the importance of recycling in the ISWM hierarchy.

Figure 3.2: Recycling in Integrated Solid Waste Management Hierarchy<sup>2</sup>

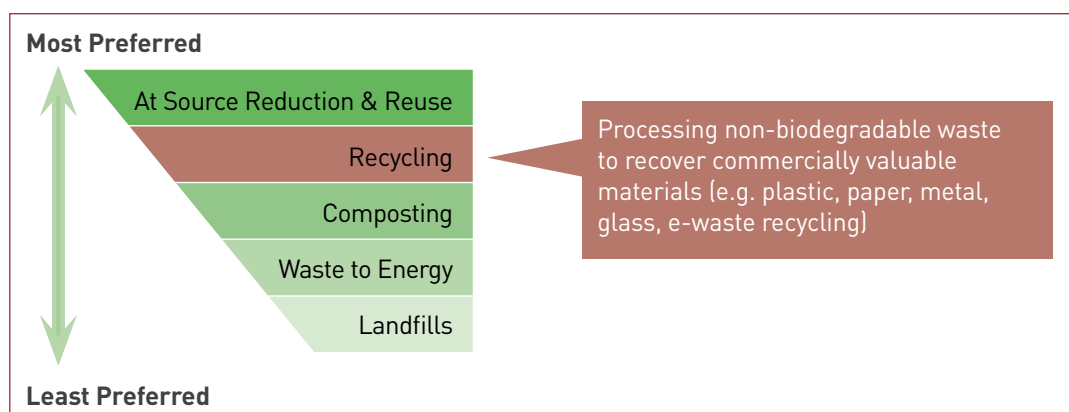

#### 3.1.1 ADVANTAGES OF RECYCLING

Recycling diverts a significant fraction of municipal, institutional and bulk waste from being dumped or disposed in landfills. This results in saving of scarce resources as well as reducing environmental impacts and the burden of waste management on public authorities. If appropriate market mechanisms are established, recycling can generate revenues, contributing to the overall cost recovery for municipal solid waste service provision

- For the ULB:
  - Reduces waste volume.
  - Cost savings in collection, transportation and disposal.

<sup>2</sup> Developed by the Expert Committee for revision of MSWM manual (2013-15).



- Longer life span for landfills.
- Reduced environmental management efforts.
- For the economy:
  - Reduction of imports of raw materials, fertilisers etc. and hence foreign currency required.
  - Livelihood opportunities for recyclers in the recycling industry.
- For the environment:
  - Sustainable use of resources
  - Reduced amount of waste going to storage sites and reduced requirement of land.
  - Reduced environmental impacts including impacts of climate change.

Recycling plays a vital role in reducing the quantity of waste, increasing resource recovery and minimising the financial and environmental burden of MSWM

### 3.1.2 ASSESSMENT OF RECYCLABLES - CHARACTERISATION AND QUANTIFICATION

As per data received from CPCB, it is estimated that urban India generated 1,43,449 metric tonnes of municipal solid waste per day in 2014-15. Of this waste 40-60% is organic and 10-20% is recyclables. This indicates there is a clear waste minimisation potential of 14,344 – 28,689 metric tonnes per day through recycling and recovery. Figure 3.3 is indicative of the typical waste fractions in municipal solid waste generated in India.



According to the Central Pollution Control Board (CPCB), urban India generates about 51 million metric tonnes of solid waste per year with a per capita waste generation rate of 0.2–0.6 kilogram per day (2014–2015).

This India-wide assessment underlines the importance of recycling. However, this information is not adequate when designing material recycling strategies for a specific municipality

Recyclables mainly paper, plastic, metal, and glass can be retrieved from the waste stream for further recycling. Table 3.1 gives an overview of typical recycling material and their recycling potential.



Every strategy for recycling (as also for other steps of municipal solid waste management) should be based on a thorough waste analysis or characterisation in the respective city. Only based on this composition and quantification of municipal solid waste, a detailed estimation of the potential for recycling of different materials is possible. Methods for waste characterisation are described in Chapter 1 of Part II.

**Figure 3.3: Municipal Solid Waste Characterisation in India<sup>3</sup>**

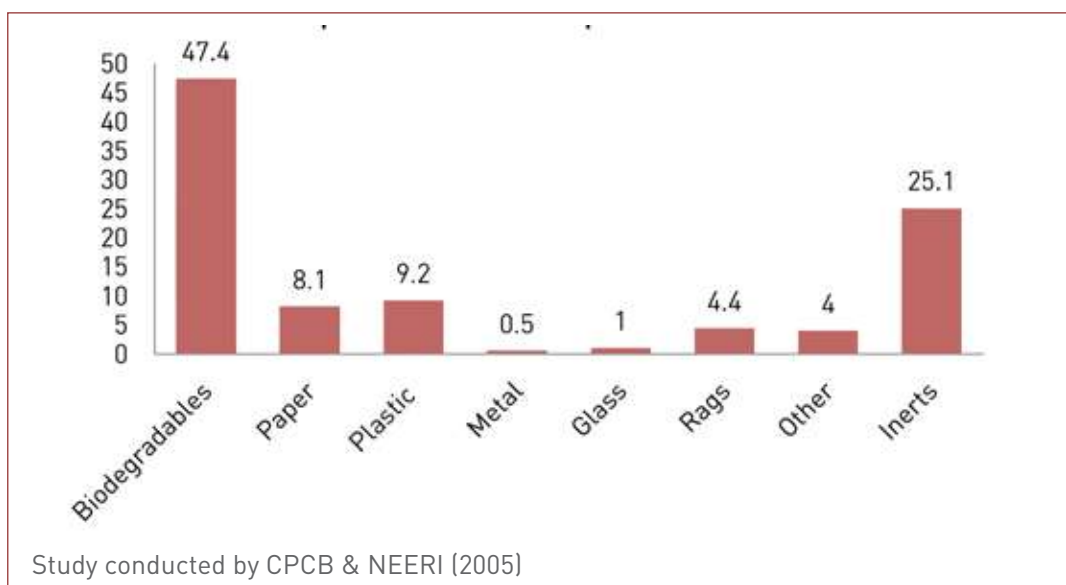

The composition of MSW depends on a large number of factors like food habit, culture, tradition, lifestyle, climate, and income. As depicted above, biodegradables make up 47.4% of the MSW stream. Metals and glass make up only about 1% each of the MSW stream because of their high potential for recycling. The inerts—street sweepings, drain silt, and construction and demolition (C&D) debris—make up 25% of the MSW stream as the street sweepings, drain silt, and construction and demolition debris eventually find their way into municipal solid waste.

**Table 3.1: Important Recycling Material: Recycling Potential and Special Conditions**

| MATERIAL  | RECYCLING POTENTIAL  | SPECIAL CONDITIONS   |
|-----------|--|--|
| Aluminium | <ul style="list-style-type: none"> <li>It has a high market value.</li> <li>It can be recycled easily by shredding and melting.</li> <li>It can be recycled indefinitely because it does not deteriorate through reprocessing.</li> <li>It requires significantly less energy than producing aluminium ore.</li> </ul> | <ul style="list-style-type: none"> <li>Separate collection is important</li> </ul>   |
| Batteries | <ul style="list-style-type: none"> <li>It recovers valuable metals.</li> <li>It protects environment from heavy metals such as lead, cadmium, and mercury.</li> </ul>  | <ul style="list-style-type: none"> <li>There is a large variety in types and sizes of batteries.</li> <li>Only some types allow adequate material recovery.</li> </ul> |

3 'Improving Solid Waste Management in India,' D. Zhu, et al., (2008). Available at: <https://openknowledge.worldbank.org/bitstream/handle/10986/6916/425660PUB0Wast12732601OFFICIAL0USE1.pdf?sequence=1>

**Table 3.1: Important Recycling Material: Recycling Potential and Special Conditions [contd.]**

| MATERIAL  | RECYCLING POTENTIAL   | SPECIAL CONDITIONS  |
|---|---|---|
| Construction and demolition waste*                | <ul style="list-style-type: none"> <li>Demolition waste can be sorted, crushed and reused for production of pavement material, flooring tiles, road construction, landscaping and other purposes.</li> <li>Due to the amounts of demolition waste, its recycling allows significant reduction of otherwise required disposal capacities.</li> </ul> | <ul style="list-style-type: none"> <li>Standards for recycled products are yet to be stipulated.</li> </ul>   |
| Glass   | <ul style="list-style-type: none"> <li>It has a moderate market value.</li> <li>It can be melted and sorted into colours.</li> <li>Recycling glass saves energy compared with processing raw material.</li> <li>It can be recycled indefinitely because it does not deteriorate through reprocessing.</li> </ul>                                    | <ul style="list-style-type: none"> <li>Broken glass can contaminate and eliminate opportunities for recycling of other material such as paper.</li> </ul>   |
| Paper and cardboard                               | <ul style="list-style-type: none"> <li>It is easily recycled.</li> <li>Paper or cardboard from recycled paper requires less energy during production and helps protect the forests.</li> </ul>  | <ul style="list-style-type: none"> <li>Recycling potential is reduced with each recycling cycle through deterioration of fibres.</li> </ul>   |
| Polyethylene terephthalate (PET)**                | <ul style="list-style-type: none"> <li>It can be recycled if segregated from other waste.</li> </ul>  | <ul style="list-style-type: none"> <li>Quality of recycled product decreases with every processing cycle.</li> <li>Recycled products have specific designated uses and cannot be used for other purposes.</li> </ul>  |
| Other plastics                                    | <ul style="list-style-type: none"> <li>Other plastics, such as polyethylene or polyvinyl chloride, can be recycled but have less value in the market than PET. The value depends on recycling and manufacturing options in the vicinity.</li> </ul>   | <ul style="list-style-type: none"> <li>Clean segregated plastics, are subjected to mechanical recycling into the same plastic type.</li> <li>Where recycling is not possible due to mixed plastics, they are then co-processed for energy recovery or used as aggregates in road material.</li> </ul>         |
| Electronic waste                                  | <ul style="list-style-type: none"> <li>It contains high value metals.</li> <li>Electronic items can be dismantled and its components reused or recycled.</li> </ul>   | <ul style="list-style-type: none"> <li>If recycling is not carried out under controlled conditions, metal is often covered with polyvinyl chloride or resins, which are often smelted or burned, causing toxic emissions.</li> <li>Disaggregation of electronic waste for recycling can be costly.</li> </ul> |
| Metal (steel, copper, nickel, zinc, silver, etc.) | <ul style="list-style-type: none"> <li>Scrap metal has a high market value, especially steel, copper, and silver.</li> <li>It can be recycled indefinitely because it does not deteriorate through reprocessing.</li> </ul>   | <ul style="list-style-type: none"> <li>High value metals, such as copper and silver, are incorporated in electronic devices, but extraction can cause severe environmental impacts, if uncontrolled.</li> </ul>   |

**Table 3.1: Important Recycling Material: Recycling Potential and Special Conditions [contd.]**

| MATERIAL   | RECYCLING POTENTIAL  | SPECIAL CONDITIONS   |
|--|--|--|
| Thermocol or Styrofoam   | <ul style="list-style-type: none"> <li>It can be processed to recover fuel and other by-products</li> <li>It can be re-ground with new expanded polystyrene for further use.</li> <li>It can be powdered and made into sheets, which can be used to make furniture.</li> </ul> | <ul style="list-style-type: none"> <li>Fuel production is through pyrolysis, gasification, and hydrocracking.</li> <li>Regulated facilities with appropriate environmental controls are required for handling thermocol recycling</li> </ul> |
| <p>* For further detailed information refer Section 3.7 of Part II<br/>           ** For further detailed information refer Section 7.4 of Part II</p> |  |  |

### 3.1.3 STAGES OF MATERIAL RECOVERY

The SWM Rules, 2016 defines “Materials Recovery Facility” (MRF) means a facility where non-compostable solid waste can be temporarily stored by the local body or any other entity mentioned in rule 2 or any person or agency authorised by any of them to facilitate segregation, sorting and recovery of recyclables from various components of waste by authorised informal sector of waste pickers, informal recyclers or any other work force engaged by the local body or entity mentioned in rule 2 for the purpose before the waste is delivered or taken up for its processing or disposal; Material recovery starts at the primary level, by households who segregate recyclables like newspapers, cardboard, plastics, bottles, etc. from waste to sell such material to local recyclers, scrap dealers or haulers. The item that cannot be sold to the kabadi system is discarded and becomes part of the MSW. Waste pickers pick up parts of this waste to earn their living. Well-segregated recyclables can directly be transferred to a processing site or to the recyclable market depending on local conditions.

The dry fraction of the segregated waste may be further segregated locally, at the transfer station or at the processing plant:

- The dry waste fraction can be segregated at the ward level, where waste from one or more wards is collected and segregated. Different recyclables are either sent directly to locally available recycling facilities or sold to wholesale dealers. The residual waste, depending on the composition, is sent for processing or disposal—compost, refuse derived fuel (RDF), landfilling. Where decentralised compost facilities are available, the wet waste fraction is processed locally.
- The dry waste fraction may also be transported to the waste transfer station, where it is further segregated. Municipal corporations can also appoint informal waste pickers for manual sorting of waste at the transfer station. Segregation at the transfer station is through manual or mechanised segregation.

- Where the dry waste fraction reaches the processing site (compost or RDF) directly, manual or mechanical pre-sorting should be carried out to recover recyclable material. This also ensures good quality process output.
- In case regional processing or disposal facilities exist, transfer of recyclables to the regional facility should be avoided. The dry waste fraction should be sorted out either at the ward level or transfer station level. If this is not possible, appropriate sorting facilities should be available at the regional facility. Figure 3.4 illustrates the different stages of materials recovery along the SWM chain.

Special waste including domestic hazardous waste that is collected either along with the dry waste fraction or separately is also to be segregated at the material recovery facility (MRF) and disposed according to the nature of the waste. Recyclable waste should be sent to the recycling industry, and hazardous waste should be disposed at the nearest treatment, storage, and disposal facility (TSDF) or as specified by the SPCB or PCC.

**Figure 3.4: Stages of Material Recovery in Municipal Solid Waste Management Chain<sup>4</sup>**

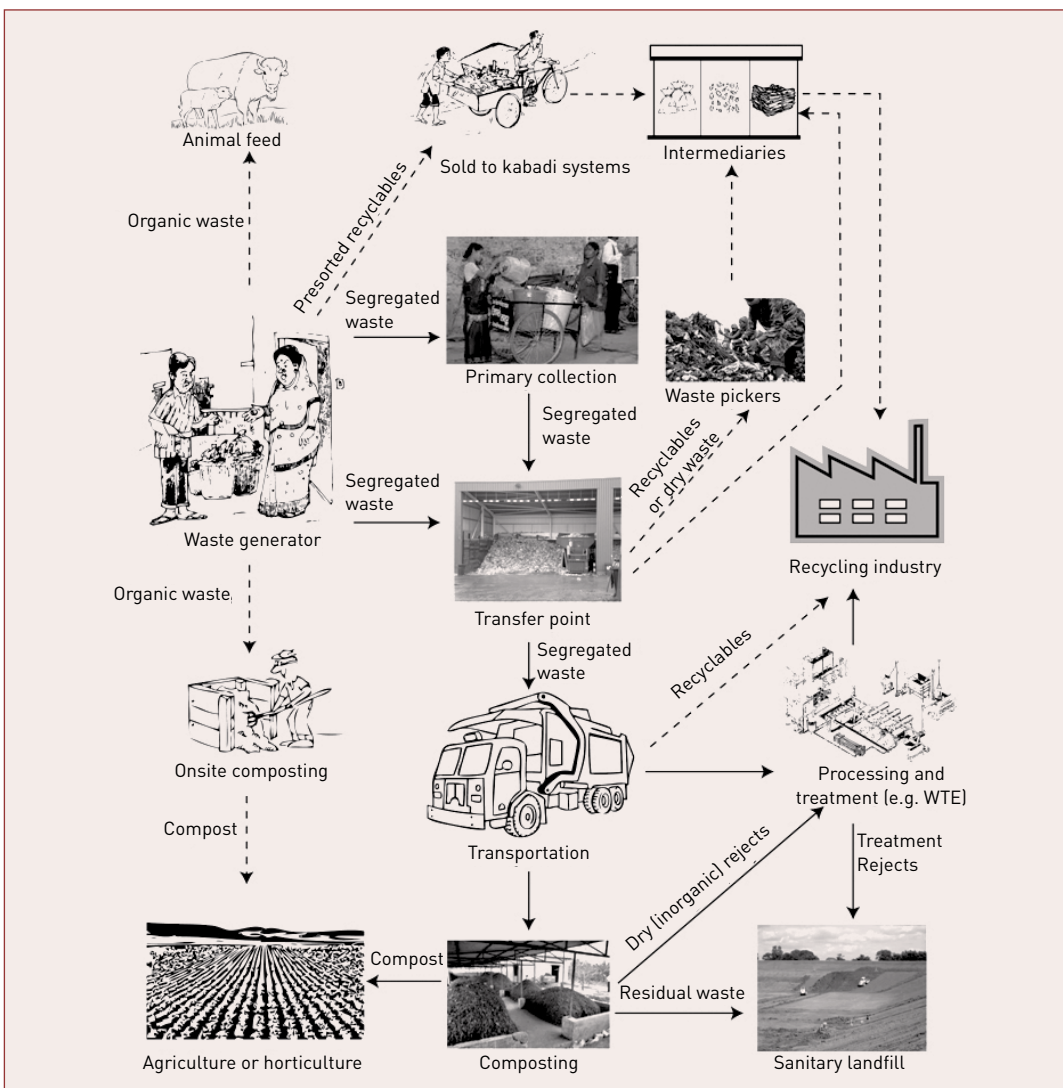

4 Adapted from: 'Improving Solid Waste Management in India,' D. Zhu, et al., [2008]. Available at: <https://openknowledge.worldbank.org/bitstream/handle/10986/6916/425660PUB0Wast12732601OFFICIAL0USE1.pdf?sequence=1>

### 3.1.4 MATERIAL RECOVERY FACILITY

As per SWM Rules, 2016:



Clause 15: Duties and responsibilities of local authorities:-

- (h) Setup material recovery facilities or secondary storage facilities with sufficient space for sorting of recyclable materials to enable informal or authorised waste pickers and waste collectors to separate recyclables from the waste and provide easy access to waste pickers and recyclers for collection of segregated recyclable waste such as paper, plastic, metal, glass, textile from the source of generation or from material recovery facilities; Bins for storage of bio-degradable wastes shall be painted green, those for storage of recyclable wastes shall be printed white and those for storage of other wastes shall be printed black;
- (r) transport non-bio-degradable waste to the respective processing facility or material recovery facilities or secondary storage facility;

A material recovery facility (MRF) accepts mixtures of waste fractions—e.g., selected materials collected in the dry waste bin (see specifications in Section 2.3 of Part II)—separates and diverts recyclable materials, and transfers the remaining waste for disposal. ULBs should identify and earmark land for recycling facilities while preparing a master plan for the city to encourage recovery of valuable resources from waste in a systematic and formalized manner. Such sorting facilities should be so designed that the solid waste stored is not exposed to open atmosphere and should be user friendly<sup>5</sup>. ULBs should also look into possibilities for establishing recycling centres at ward level to enhance maximum materials recovery.

The configuration of a MRF processing line is critical to the overall quality of the materials segregated by the line. It depends on numerous factors including the type and quantity of materials to be processed, quality and quantity of incoming waste, desired processing rates, and required specifications for the end products. While no two MRFs are identical, they generally employ common design principles and sequencing in the configuration of equipment and labour.

#### 3.1.4.1 TYPES OF MATERIAL RECOVERY FACILITY

Depending on the scale of operations and the level of mechanisation in the facility, MRFs may be classified as manual or mechanised. Usually small-scale units, manual MRFs largely employ manual sorting practices and are typically owned, managed, and operated by the informal sector. Material is segregated based on the types of waste (paper, plastic, metal, glass etc.) and gradation of material within each waste type (e.g., paper segregated into news print, office paper, packaging paper, printed books, etc.). Segregated material is then sold to intermediaries, who supply material in bulk to the recycling industry. Mechanised MRFs are large facilities with sophisticated systems and

Configuration of a MRF depends upon factors such as type and quantities of material to be processed, quality and quantity of incoming waste, processing rates and desired quality of end products

5 Materials Recovery Facility Technology Review, 2009. Available at: [http://www.dep.state.fl.us/waste/quick\\_topics/publications/shw/recycling/InnovativeGrants/IGYear9/finalreport/Pinellas\\_IG8-06\\_Technology\\_Review.pdf](http://www.dep.state.fl.us/waste/quick_topics/publications/shw/recycling/InnovativeGrants/IGYear9/finalreport/Pinellas_IG8-06_Technology_Review.pdf)





equipment that enable efficient separation of large quantity of material into different fractions. Mechanised MRFs are operating in some industrialised nations; such facilities do not exist yet in India.

Configuration of the MRF processing line will vary depending on how material is received:

- Mixed stream:** Unsegregated waste mixed with biodegradable and non-biodegradable material is collected and sent to the processing facility. At the processing facility, the mixed waste stream may be segregated manually or mechanically to separate recyclable material from compostable and inert waste (Figure 3.5). Compostable matter and recyclable materials may then be processed separately, and residual inert wastes should be sent to the landfill.

**Figure 3.5: Indicative Material Recovery Facility and Pre-sorting Facility for Mixed Waste<sup>6</sup>**

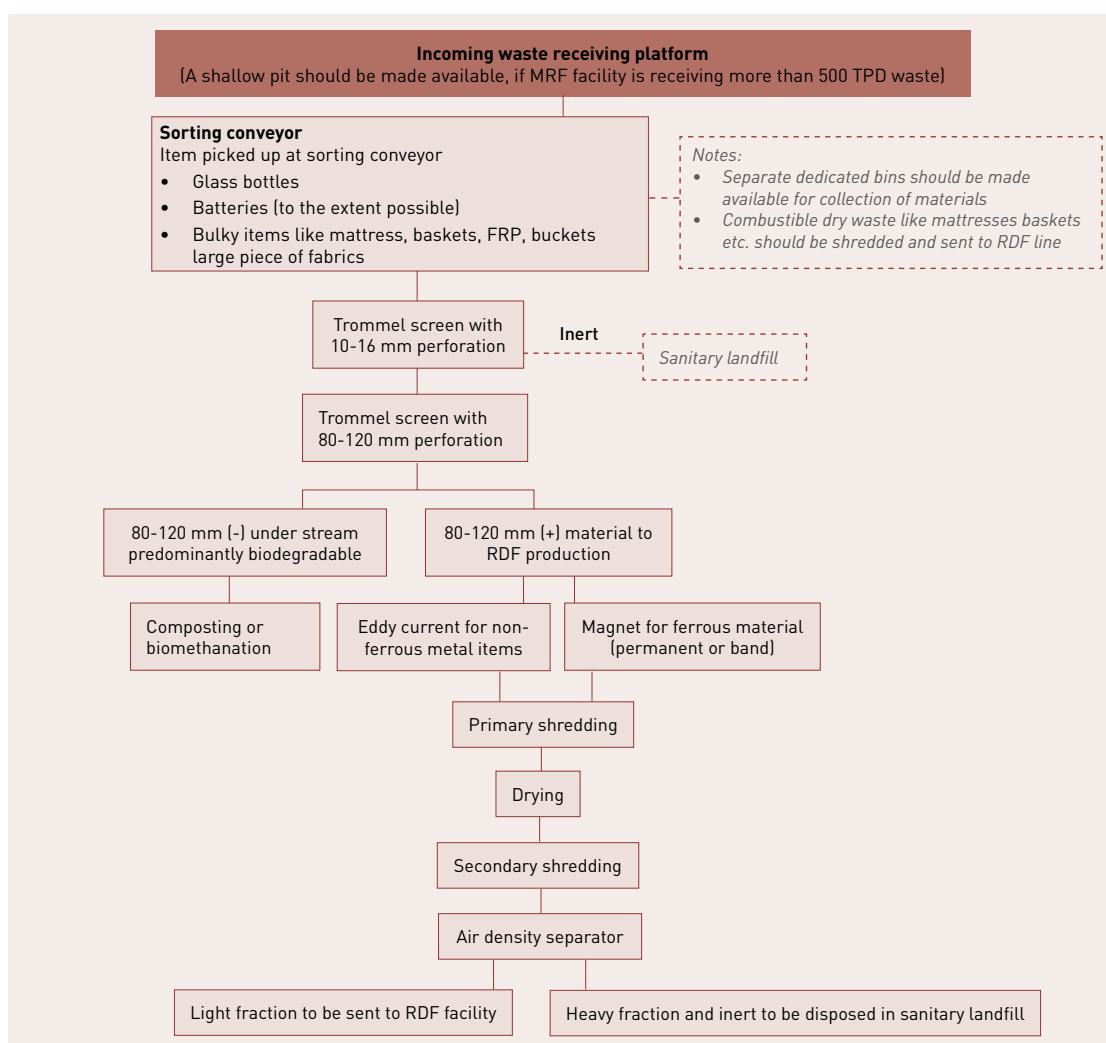

- Source separated:** MSW is segregated into biodegradable and recyclables at the point of generation before it is collected. Further, incoming recyclables are sorted at the point of collection. Some processing might be needed for further sorting of material, such as steel cans from aluminium cans, glass by colour, paper by quality, etc.,

6 Developed by the Expert Committee for revision of MSWM manual (2013-15).

but the primary purpose of the facility is to remove contaminants and prepare the material for marketing, often by baling, flattening, or crushing.

- Dry waste stream:** Dry segregated material is received in a mixed form consisting of a combination of fibres (paper, card board, mixed paper, magazines, etc.) and commingled containers (plastic, glass, metal, etc.), among other materials. The first stage of processing typically uses manual labour or equipment that separate material into various streams (fibre, paper, plastic, containers, etc.). These recyclables are also sorted by using automated machines when quantities to be handled are large. Below is a flowchart (Figure 3.6) depicting the indicative MRF and pre-sorting facility dedicated to dry waste.

**Figure 3.6: Indicative Material Recovery Facility and Pre-sorting Facility Dedicated to Dry Waste**

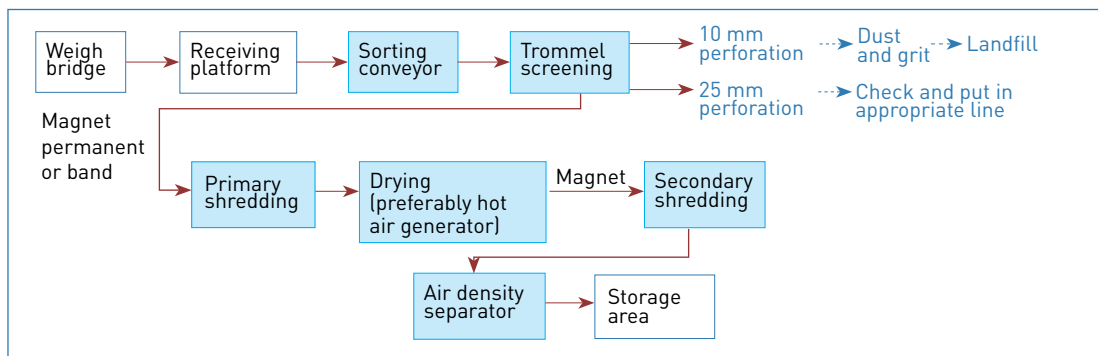

- Wet waste stream:** If the ULB intends to compost biodegradable or wet waste, the wet waste that is segregated either at the source or at the mixed waste receiving MRF facility should be further pre-processed before being placed in windrows or sent for biomethanation. The pre-processing is carried out at the composting facility. Figure 3.7 outlines the pre-processing and processing at a windrow composting facility.

**Figure 3.7: Indicative Material Recovery Facility and Pre-sorting Facility Dedicated to Wet Waste**

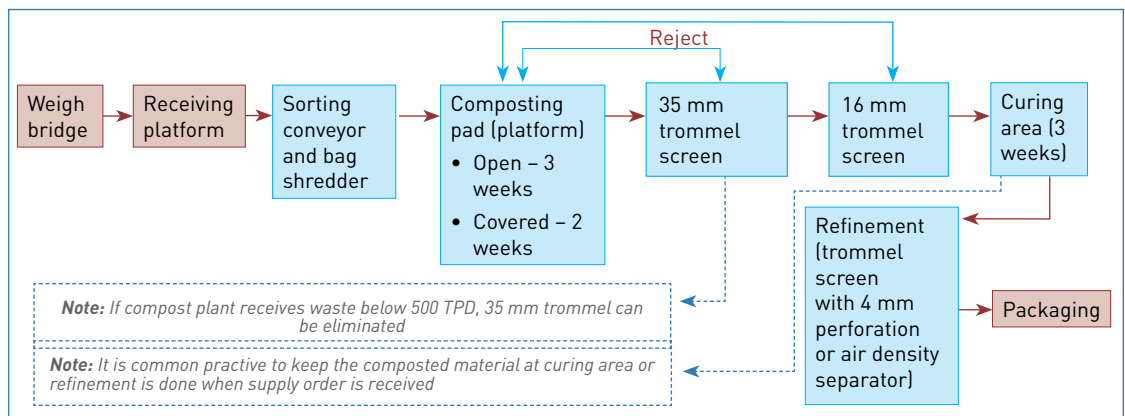

Configuration of MRF also depends on the types of incoming waste; whether the incoming waste is source separated, dry waste stream or mixed waste stream



### 3.1.4.1.1 UNIT PROCESSES IN MATERIAL RECOVERY FACILITY

MRF units employ varying combinations of manual and mechanical processes, based on the type of facility, availability of equipment, labour availability, and associated cost implications. MRF units employing manual labour for sorting operations have relatively lower costs, but may also operate at lower efficiencies compared with mechanical sorting facilities.

An MRF unit, depending on the level of complexity, will consist of a combination of units in varying degrees of mechanisation (as shown in above figures):

- **Pre-sorting:** Bulky and contaminated wastes hamper further sorting or processing in the facility; mechanical or manual pre-sorting is essential to separate out these wastes. Manual sorting results in higher labour costs and lower processing rates. Manual sorters remove bulky waste as the waste passes along a conveyor belt, which carries the pre-sorted waste to the mechanised sorting unit of the facility.
- **Mechanical sorting:** Mechanical processes based on principles of electromagnetics, fluid mechanics, pneumatics, etc. are used to segregate the different waste streams in the pre-sorted waste. Mechanical processes require specialised equipment for segregation of commingled municipal waste. Mechanical sorting typically employs the following processes:
  - **Screening:** Screening achieves an efficient separation of particles into two or more size distributions. Two types of screens are used in MRF centres disc screens and trommels.
  - **Ferrous metal separation:** In the second stage, electromagnets are used for separating heavy ferrous metals from mixed waste.
  - **Air classification:** The residual waste stream is passed through an air stream with sufficient velocity to separate light materials from heavy material, specifically for separating out lightweight plastics and paper from the mixed stream. Three types of air classifiers may be employed: (i) horizontal air classifier, (ii) vibrating incline air classifier, and (iii) incline air classifier. Heavy or bulky plastics are sorted out either in the pre-processing line (manually) or in the “detect and routing” systems, employed at later stages of material recovery.
  - **Non-ferrous metal separation:** The non-ferrous metal separator segregates zinc, aluminium, copper, lead, nickel, and other precious metal from commingled waste. An eddy current separator removes non-ferrous items from the commingled waste based on their electrical conductivity.
  - **Detect and route system:** This system separates various grades of paper, plastics, and glass, which are not sorted out in the air classifier. This system works in two stages. The first stage employs

programmed optical sensors to determine the nature of different materials. In the second stage, based on information received from the sensor, sorted material is routed to appropriate bins by directional air jets.

- **Size reduction:** Sorted materials after segregation are usually too large for further use or processing; they should be reduced to smaller sizes.
- **Baling:** Sorted and sized material is baled for further processing or use.

**Table 3.2: Different Processes or Stages and Equipment Employed in a Material Recovery Facility**

| PROCESS OR STAGES                       | EQUIPMENT   |
|---|---|
| Pre-sorting material handling equipment | <ul style="list-style-type: none"> <li>• Belt conveyor</li> <li>• Screw conveyor</li> <li>• Apron conveyor</li> <li>• Bucket elevator</li> <li>• Drag conveyor</li> <li>• Pneumatic conveyor</li> <li>• Vibrating conveyor</li> <li>• Debagger</li> </ul> |
| Ferrous metal separation                | <ul style="list-style-type: none"> <li>• Magnetic separator and screening</li> </ul>  |
| Screening                               | <ul style="list-style-type: none"> <li>• Disc Screening</li> <li>• Trommels</li> </ul>  |
| Air classification                      | <ul style="list-style-type: none"> <li>• Horizontal air classifier</li> <li>• Vibrating inclined air classifier</li> <li>• Inclined air classifier</li> </ul>   |
| Non-ferrous metal separation            | <ul style="list-style-type: none"> <li>• Rotating disk separator</li> <li>• Eddy current separator</li> </ul>   |
| Size reduction                          | <ul style="list-style-type: none"> <li>• Can densifier</li> <li>• Can flattener</li> <li>• Glass crusher</li> <li>• Plastic granulator</li> <li>• Plastic perforator</li> <li>• Baler</li> </ul>  |
| Pollution control                       | <ul style="list-style-type: none"> <li>• Dust collection system</li> <li>• Noise suppression devices</li> <li>• Odour control system</li> <li>• Heating, ventilating, and air conditioning (hvac)</li> </ul>  |
| Other fixed equipment                   | <ul style="list-style-type: none"> <li>• Fixed storage bin</li> <li>• Live-bottom storage bin</li> <li>• Floor scale for pallet or bin loads</li> <li>• Truck scale</li> <li>• Belt scale</li> </ul>  |

Recyclables separated from mixed waste usually have the lowest quality and might be contaminated by residual waste. In India, the segregation of recyclables from the mixed waste stream is often practiced, not through formal collection systems, but through informal workers (waste pickers).



Options for optimising this system through better inclusion of informal workers are explained in Section 2.3.7 of Part II.

### 3.1.5 NEED FOR ESTABLISHING MARKET LINKAGES AND EXTENDED PRODUCER RESPONSIBILITY

Any recycling programme depends on two crucial factors: community awareness and willingness to cooperate, and access to markets for segregated materials with acceptable and reliable conditions.

Market development for recyclables involves an assessment of the supply as well as the demand. The supply of recyclable materials should meet the requirements of recycling industries, both in terms of quality and quantity.

Products made from recyclable materials should meet market requirements as well. Unless a community has an established market for materials it collects, it may end up temporarily storing some materials and later landfilling some or all of them.

Market establishment for recyclables might take place with or without intervention of the ULB, the latter in the framework of extended producer responsibility (EPR) discussed in Section 1.2.2 of Part II.

Various voluntary industrial initiatives have started recently where industries have set up their own collection and recycling systems. Mineral water suppliers voluntarily take back mineral water containers and refund the customer for the returned containers. Breweries buy back beer bottles from the kabadi system. There are also examples of different breweries using a bottle design to facilitate reuse of these bottles, which are collected by the informal system. “Go Green with Tetrapak” initiative launched by Tetrapak in 2010 along with a retail chain encourages customers to deposit their used, empty Tetrapak cartons (tetrapaks) at the store for recycling. More than 6,00,000 tetrapaks have been collected at 130 collection points in Mumbai since the initiative’s inception. The recycling of 6,00,000 empty tetrapaks so far has saved over 75 trees.<sup>7</sup>

EPR initiatives also benefit industries through saved production costs. Manufacturers and suppliers are ideal partners for municipal public private partnerships (PPPs) for development of drop off sites and take back facilities. Companies manufacturing durables (e.g., Nokia, LG, and Samsung) are in the process of establishing drop-off points for used electronics and components at various points of sale in the larger Indian cities. Such initiatives may be strengthened through appropriate municipal guidelines and bye-laws.

The type of materials in demand in the recycling market determines the level of segregation and segregated collection

It is necessary for decision makers to assess and establish market linkages prior to bringing recycling programmes into operation

Local governments should encourage businesses to adopt and promote recycling initiatives, e.g., take-back of large mineral water containers

<sup>7</sup> Tetra Pak. 2014. *Go Green with Tetra Pack Recycling now reaches Mumbaikars through nearly 130 carton collections points*. 16 February. <http://www.tetrapak.com/in/about-tetra-pak/press-room/news/go-green-mumbai>

### 3.1.6 INFORMAL SECTOR INVOLVEMENT IN RECYCLING

Informal sector contributes significantly to improving resource efficiency, thereby enhancing environmental and climate protection

In India, recyclable material is either purchased by the kabadi system from the source of waste generation or picked up by waste pickers. Municipal authorities can promote recycling by educating the citizens and training them in segregating waste at source into dry, wet and domestic hazardous categories and handing over segregated wastes to waste collectors. Recyclable material is sold to the recycling industry through a chain of intermediaries. Waste collected by the kabadi system is sorted and sold to intermediaries who further clean, sort and store the waste. Waste pickers pick up discarded recyclable materials from primary and secondary collection points including dumpsites or landfills, and sell such material to the appropriate recycling industry. It has been estimated that the informal sector alone recovers as much as 56% of recyclable material.<sup>8</sup> All such activities should be compliant with environment, safety, health, and hygiene norms.

The informal recycling sector:

- supplements the formal system;
- manages all types of waste through the informal network;
- provides employment to a large number of people;
- operates competitively and with high levels of efficiency;
- establishes linkages with the formal economy at some point in the recycling chain; and
- offsets carbon emissions by making recycling possible and thus reducing the extraction and use of virgin raw materials.

Involvement of child labour, littering on street, exploitation by middle men are some of the issues that need immediate attention from local governments

However, there are some potential points of conflict between formal municipal solid waste management (MSWM) services and informal recycling activities that need to be recognized and addressed while attempting integration of the two systems. The current informal practice of materials recovery and recycling by individual waste pickers who leave behind unwanted waste leads to some litter remaining on the streets. Targeted as the sole cause of litter on the streets, the waste pickers are frequently banned from residential areas. These areas are the best places to retrieve recyclable waste, but harassment of waste pickers forces them to collect recyclables from landfill sites, a practice that leads to even higher health threats and environmental pollution. The presence of waste pickers or scavengers at transfer stations and landfill sites can interfere with vehicle movement, which is dangerous, increasing vehicle turnaround and thus reducing efficiency. The waste pickers work under unacceptable working conditions and many of them are exposed to health issues. In most cases, waste pickers are women and children from low-income groups, the most vulnerable groups in the Indian society. They are often exploited by middlemen or waste merchants because of their low social status. Child labour is also a matter of great concern.

8 Promoting Recycling in Municipal Solid Waste Management through Sustainable Business Models. Janya, S. 2014. RETA 7450 Project Preparation Support for Livable Cities.

As long as the door-to-door collection system is not operationalised and segregated waste is not collected from the doorstep, waste pickers would continue to earn their living from rag picking at the cost of their health and well-being. The solution lies in organizing and training waste pickers to enable access to upgraded livelihoods, e.g., waste pickers as source waste collectors through self-help groups (SHGs), resident welfare associations (RWAs), community-based organisations (CBOs), non-government organisations (NGOs), cooperatives, or the private sector, and thereby improving their quality of life.

These welfare activities can be undertaken through social development programmes in collaboration with local NGOs which provide schools, health care facilities, etc., to waste pickers. Children should be kept away from these activities. Provision of a valid identity card to waste pickers through local NGOs or CBOs, and creation of health schemes, access to medical facilities, and regular medical checks can help in improving the lives of waste pickers. The ULB should identify a specific agency to conduct this activity periodically, at least once every 2 years. This would help identify waste pickers and facilitate their easy integration into formal waste management systems.

Refer to Section 1.2.4 of Part II for further details on informal sector integration into conventional solid waste management services.

### 3.1.7 RECYCLING OF PLASTICS

It is estimated that approximately 4,000 to 5,000 TPD of plastic waste is generated in India; that is roughly 4%–5% by weight of MSW. The major problems in plastic waste management are collection, segregation and disposal. At present, plastic waste collection is done through the informal sectors such as the kabadi system and waste-pickers<sup>9</sup> (refer Section 7.4.4 of Part II).

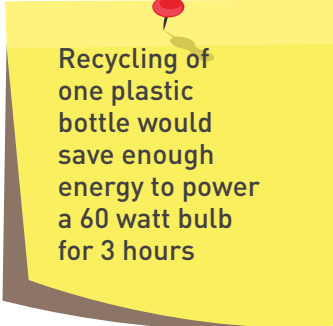

Recycling of one plastic bottle would save enough energy to power a 60 watt bulb for 3 hours

### 3.1.8 THERMOCOL RECYCLING

Thermocol or Styrofoam, scientifically known as expanded polystyrene, is produced from a mixture of about 90%–95% polystyrene and 5%–10% gaseous blowing agent (pentane gas or carbon dioxide). Thermocol is an excellent material for packaging goods (especially electronic goods) and for the construction and decorating industry because it is light and has good insulating properties. Environmentally sound recycling of thermocol still remains to be commercially established in India, and thermocol recycling regulation is yet to be notified.

Different methodologies are available for recycling thermocol, e.g., grinding and mixing it with new beads, shredding it into fine powder, reducing

9 Available at: [http://cpcbenviis.nic.in/newsletter/URBAN%20WASTE%20PROFILE\\_LV.pdf](http://cpcbenviis.nic.in/newsletter/URBAN%20WASTE%20PROFILE_LV.pdf) CPCB (2010).

its volume using solvents (Bhabha Atomic Research Centre [BARC] process), etc.

Pune's Science and Technology Park has set up a plant at Ranjangaon to recycle discarded thermocol into cheap furniture items. The furniture manufactured from recycled thermocol is relatively cheap, durable, and fireproof. A hub of electronic industries, Ranjangaon produces 10 TPD of thermocol waste.

A thermocol compactor may also be used to reduce the bulk of thermocol waste generated within a ULB. This compacted thermocol is then sold to the recycling market for further processing or recycling.



#### **Initiative of Corporation of Panaji for Managing Thermocol Waste**

Corporation of Panjim has installed a styropactor in the MRF for dealing with the large quantities of thermocol that are generated in the city. The thermocol compactor compresses the thermocol which is then auctioned to bulk recyclers on a regular basis.

### **3.1.9 RECYCLING PAPER AND BOARD**

In India, the informal sector mainly performs the collection of waste paper through door-to-door collectors, kabadi system, and waste pickers. The informal sector carries out as much as 95% of the collection of waste paper in the country. The value chain comprises direct collection from various source points and small shops, where primary sorting of waste into different categories takes place; (ii) zonal segregation centres owned by wholesalers, where the waste material gets collected from small shops and baled; and (iii) finally dispatched to end users, which are usually paper mills.

Paper recyclers are developing new technologies for handling, identifying and separating paper grades for recycling. One such technology allows segregation of paper fibres during the recycling process according to fibre length, coarseness, and stiffness through a sequential centrifuging and screening process.



#### **Relevance of paper and cardboard in the waste stream**

The growth in the paper industry has mirrored the growth in gross domestic product (GDP) of the country; an annual average growth of 6%–7% has been observed over the last decade. Globally, India is the fastest growing market for paper. Economic projections even assume that growth in paper consumption would exceed GDP growth, with an annual growth close to 9%. Consequently, the import of pulp and paper products is likely to show a growing trend. These figures demonstrate the high relevance of paper and cardboard as a fraction of the MSW.<sup>8</sup>





### 'Wealth Out of Waste (WOW) in South India

ITC Paperboards and Specialty Papers Division launched the wastepaper collection programme called Wealth Out of Waste (WOW) in 2011 in select areas in Hyderabad, Bengaluru, and Coimbatore. WOW is expanding to more areas in South India. In Chennai, the division has tied up with 30–40 information technology (IT) companies, including Infosys, IBM, and Wipro, which would sell their wastepaper to ITC for recycling. ITC also plans to tie up with residential welfare associations (RWAs), non-government organisations (NGOs), and urban local bodies (ULBs) to expand WOW.<sup>9</sup>



### Making of Handmade Paper

The Indian handmade paper industry produces a variety of paper and paper products mainly by using wastepaper collected from various sources (e.g., schools and colleges) and other materials such as cotton rags, tailor cuttings, hosiery cuttings, etc. Other agro-based fibres available in the North Eastern region like jute, sabai grass, ramie, banana, straw, angelie grass, elephant grass, etc. are also used to blend with the primary fibres for mottling effects and to manufacture special varieties of thin paper.

The basic steps of recycled handmade paper making process are the following:

#### A. CHOPPING AND DUSTING

The paper raw material and waste cotton rags are sorted manually to remove unwanted materials like plastics, iron and dust etc. that could contaminate pulp. Once the material is sorted, it is put through a rag chopper that cuts the rags into small uniform sized pieces. While the wastepaper is directly sent to the beater after being dipped in the water for 3 to 4 hours, 2 to 3 people could be engaged in this phase depending upon the amount of raw material.

#### B. BEATING

The chopped rags are converted into a fine pulp in a Hollander Beater. Pulping of the raw materials is done using non-polluting chemicals or agents such as lime, soda ash, caustic soda, oxalates, oxygen, and peroxides. It is not necessary to use harmful chemicals like alkali sulphide and sulphite, and chlorine and chlorine compounds for the delignification processes. Rosin soap and alum are added to give the paper the desired physical properties and the required consistency. When making coloured or textured paper, colour dyes, straw, hemp, grass etc. are added in this phase. The resulting pulp is now ready for sheet formation.

#### C. SHEET FORMATION

There are two methods of sheet formation which are being used in India:

- i. **Lifting:** Lifting is a modern method done with the help of Univat. Lifting employs the use of a steel water tank fitted with an apparatus to lift the mould. The mould is clamped between two wooden frames in a water tank. A measured quantity of the pulp, depending on the thickness of the paper required, is poured evenly into the mould.

10 Effective Recycling of Waste Paper for Production of Good Quality Newsprint. Tyagi S., V. Mohan, Roy Choudhary, K et. al. (2013), Available: [http://www.ipptaonline.org/July-Sept,%202013/2013\\_Issue\\_3\\_IPPTA\\_Article\\_02.pdf](http://www.ipptaonline.org/July-Sept,%202013/2013_Issue_3_IPPTA_Article_02.pdf)



Univat being used for sheet formation



Rag-chopper



Hollander beater

This mould is then shaken side to side horizontally and raised mechanically to drain excess water. A sheet of pulp is formed over the mould which is taken out after unclamping the frame.

- ii. **Dipping:** Dipping is a traditional method where the pulp is transferred from the beater into a masonry trough or vat. Depending on the thickness of the paper required, the pulp is diluted by mixing it with water. The mould made of a wooden frame with a wire mesh or a bamboo stick mat is dipped by hand into the pulp. The frame is then shaken side to side and lifted out of the vat. A sheet of pulp is formed over the mould. Out of the two processes, lifting is favoured more as dipping requires constructing masonry trough or vat.

#### D. PRESSING AND DRYING

A manual or hydraulic press is used for squeezing out the excess water from the sheets. This compresses the pulp adding strength to the fibre and facilitating the drying process.

#### E. CALENDARING

The calendaring machine is fitted with two chilled cylinders rotating in opposite direction to give a smooth finish to the sheets of paper passed through them. Calendaring also tends to enhance the gloss of the paper.

#### F. SHEET CUTTING

At this phase, the calendered sheet still has a deckle edge. The sheets are cut to standard size of 22"x 30" or to desired sizes as required by the customers.

#### G. PAPER PRODUCTS

While it is possible to manufacture several handmade recycled paper products, there is a consistent market demand for select products such as papier-mâché, notebooks and diaries, stationeries, lampshades, invitation cards, and office paper.

The municipal authorities should promote recycling of paper to save trees and other natural resources. This will provide employment to skilled and unskilled labor and correspondingly reduce the municipal authority's waste management costs.



Paper Products

### 3.1.10 RECYCLING OF GARDEN WASTE OR YARD WASTE

Yard waste consists of grass, leaves, and tree and bush trimmings. The horticulture waste from parks and gardens should be composted at the site or at a decentralised facility, thereby reducing the amount of yard waste entering the solid waste stream. Additionally, grass clippings, leaves, and woody yard wastes can also be used as mulch in gardens and around shrubs to keep the soil moist, control weed growth, and add nutrients. Organic material, e.g., straw, dried stems, etc., containing higher percentage of lignocellulosic material takes much longer time for composting process to complete (for details refer Section 3.2 of Part II). These can be readily converted into mulch in shorter period of time.

### 3.1.11 CONSTRUCTION AND DEMOLITION WASTE

Construction and demolition (C&D) waste generally constitutes about 10%–20% of total urban solid waste.<sup>11</sup>

The report of the Supreme Court's expert committee in 1999 and the SWM Rules, 2016 recommend that ULBs shall facilitate the separate collection and transportation of C&D waste. Due to the challenges associated with processing and disposal of C&D waste, separate rules have been established namely Construction and Demolition Waste Management Rules, 2016 that describes the management of C&D waste and roles and responsibilities of various stakeholders.

C&D and other inert waste may be utilised for making bricks, pavement blocks, construction materials such as aggregates etc. Ward level debris deposit sites should be created. Containers could be provided at such locations, and a small collection charge could be levied for receiving such waste and transporting it for disposal. Rates may be prescribed for such collection by the ULB, and contracts could be given for managing such sites. Helplines should be created to ensure prompt clearance of C&D waste.

ULBs must make serious efforts to utilise C&D waste and should motivate the private sector to set up processing plants. There are several plants of various capacities in India to make bricks, paver blocks, aggregates, etc. out of such waste material. Profitable use of C&D waste will minimise the cost of managing such waste and requirement for valuable landfill space, besides giving employment opportunities to unemployed youth. It will also save natural resources and reduce the use of virgin soil.

11 "Rebuilding C&D Waste Recycling Efforts in India", Ghosh, G., Ghosh, S. & Aich, A., (n.d.), Waste Management World. Available at: <http://www.waste-management-world.com/articles/print/volume-12/issue-5/features/rebuilding-c-d-waste-recycling-efforts-in-india.html>

Section 3.7 of Part II provides details on C&D waste collection and transportation. The potential and appropriate processes for recycling C&D waste are also discussed in detail.

### 3.1.12 E-WASTE

E-waste or waste electrical and electronic equipment (WEEE) includes surplus, obsolete, or broken electrical or electronic devices. Its quantum is increasing yearly, and disposal of e-waste is becoming a global environmental and public health issue.

According to a study,<sup>12</sup> India generates annually about 3,80,000 tonnes of e-waste, which is expected to increase manifold. The study also reveals that only about 6% of e-waste is recycled, of which 95% is operated through the informal sector. While mainly interested in precious metals (such as copper, silver, and platinum), recyclers are also interested in glass, plastic, and batteries within these devices. Currently applied processes for recycling WEEE are largely unscientific and environmentally unsound, hence posing serious health threats. It will be a challenge to reorganise the recycling of WEEE to establish recycling methods that protect both workers and the environment. One option would be the introduction of the extended producer responsibility (EPR) concept, where the producer of an electrical or electronic device guarantees product redemption after use through recycling or disposing it in an environmentally friendly way (for details refer to Section 7.7 of Part II).

### 3.1.13 GREENHOUSE GAS MITIGATION POTENTIAL FROM RECYCLING AND REUSE

Waste handling and disposal generates greenhouse gases (GHG) both directly and indirectly. The most efficient way to reduce direct and indirect GHG emissions in waste management is to reduce waste generation at source, followed by material recycling. Direct emissions are decreased when waste is not disposed at landfills nor treated in any other way (e.g. combustion). Indirect emissions can be cut down by decreasing the energy consumption both in acquiring and producing raw material and also in manufacturing the product itself. It is possible to substitute virgin material with recovered material. In most cases, the replacement of virgin material by recycled material decreases the use of net energy and thus the GHG emissions. For example, recycling 1 tonne of paper reduces 1 metric tonne of carbon dioxide (CO<sub>2</sub>) equivalent emissions. Similarly, recycling 1 tonne of aluminium avoids approximately 9 tonnes of CO<sub>2</sub> equivalent emissions. As a result, use of recycled material in place of fresh material could lead to reduction in GHG emissions. On the other hand, recycling practise can also result

12 Carried out by MAIT and GIZ in 2007

in GHG emissions either from transportation of material or from the recycling process itself.

## 3.2 COMPOSTING

Municipal solid waste (MSW) primarily consists of organic, inorganic, and inert fractions. Under natural conditions, the organic fraction of waste continually decomposes, accompanied by a strong foul odour and production of gases, which are predominantly methane or CO<sub>2</sub> depending on the aerobic condition of the decomposing mass. Vector infestation during the natural decomposition is a common phenomenon.

Composting is a process of controlled decomposition of the organic waste, typically in aerobic conditions, resulting in the production of stable humus-like product, i.e., compost.

Considering the typical composition of wastes and the climatic conditions, composting is highly relevant in India and should be considered in all municipal solid waste management (MSWM) concepts. Composting of the segregated wet fraction of waste (see Section 2.2 of Part II) is preferred. Mixed waste composting, with effective and appropriate pre-treatment of feedstock, may be considered as an interim solution; in such cases, stringent monitoring of the compost quality is essential.



Composting is a biological process in which microorganisms convert organic matter into compost

### 3.2.1 SOLID WASTE MANAGEMENT RULES, 2016: GUIDANCE ON COMPOSTING



As per SWM Rules, 2016:

Clause 4 Duties of waste generator:-

- (6) All resident welfare and market associations shall, within one year from the date of notification of these rules and in partnership with the local body ensure segregation of waste at source by the generators as prescribed in these rules, facilitate collection of segregated waste in separate streams, handover recyclable material to either the authorised waste pickers or the authorised recyclers. The bio-degradable waste shall be processed, treated and disposed off through composting or biomethanation within the premises as far as possible. The residual waste shall be given to the waste collectors or agency as directed by the local body.
- (7) All gated communities and institutions with more than 5,000 sqm area shall, within one year from the date of notification of these rules and in partnership with the local body, ensure segregation of waste at source by the generators as prescribed in these rules, facilitate collection of segregated waste in separate

streams, handover recyclable material to either the authorised waste pickers or the authorized recyclers. The bio-degradable waste shall be processed, treated and disposed off through composting or biomethanation within the premises as far as possible. The residual waste shall be given to the waste collectors or agency as directed by the local body.

- (8) All hotels and restaurants shall, within one year from the date of notification of these rules and in partnership with the local body ensure segregation of waste at source as prescribed in these rules, facilitate collection of segregated waste in separate streams, handover recyclable material to either the authorised waste pickers or the authorised recyclers. The bio-degradable waste shall be processed, treated and disposed off through composting or biomethanation within the premises as far as possible. The residual waste shall be given to the waste collectors or agency as directed by the local body.



#### Clause 15 Duties and responsibilities of local authorities:

- (m) collect waste from vegetable, fruit, flower, meat, poultry and fish market on day to day basis and promote setting up of decentralised compost plant or biomethanation plant at suitable locations in the markets or in the vicinity of markets ensuring hygienic conditions;
- (q) transport segregated bio-degradable waste to the processing facilities like compost plant, biomethanation plant or any such facility. Preference shall be given for on site processing of such waste;
- (u) phase out the use of chemical fertilizer in two years and use compost in all parks, gardens maintained by the local body and wherever possible in other places under its jurisdiction. Incentives may be provided to recycling initiatives by informal waste recycling sector.
- (v) facilitate construction, operation and maintenance of solid waste processing facilities and associated infrastructure on their own or with private sector participation or through any agency for optimum utilisation of various components of solid waste adopting suitable technology including the following technologies and adhering to the guidelines issued by the Ministry of Urban Development from time to time and standards prescribed by the Central Pollution Control Board. Preference shall be given to decentralised processing to minimize transportation cost and environmental impacts such as-
- a) biomethanation, microbial composting, vermi-composting, anaerobic digestion or any other appropriate processing for bio-stabilisation of biodegradable wastes;

### 3.2.2 COMPOSTING IN THE INTEGRATED SOLID WASTE MANAGEMENT FRAMEWORK

The third preferred choice in the ISWM strategy, i.e., adoption of resource recovery strategies and composting, ensures that waste is processed appropriately to facilitate further use of the material. Composting is a biological process of stabilising biomass either in the presence or absence of free oxygen, carried out by a host of microbes. Aerobic composting, which is carried out in the presence of air, is far more popular because it is much faster compared with the “trench” composting where direct access to air is denied. Processing of MSW by this process yields humus rich compost (organic manure) along with macronutrients and micronutrients for plants.

Figure 3.8: Composting in the Integrated Solid Waste Management Hierarchy

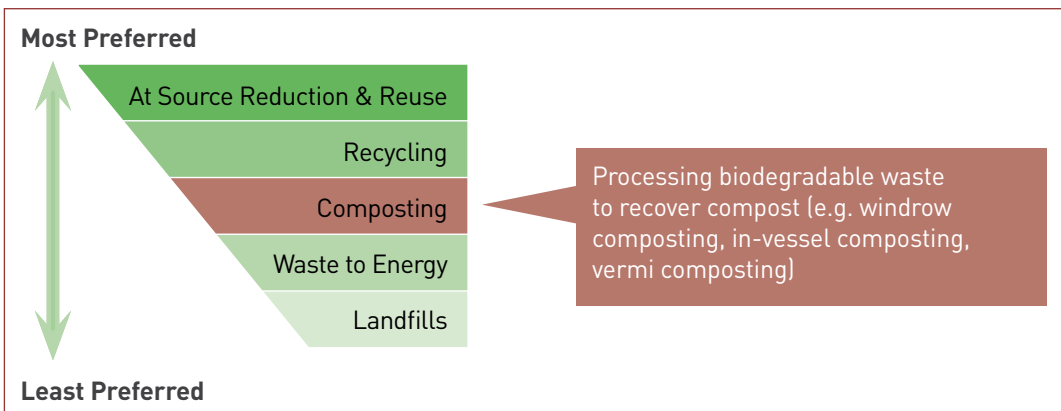

Composting is the third preferred choice in the ISWM hierarchy. It ensures that waste is processed appropriately to facilitate material recovery

Given the propensity of organic waste to contribute to environmental pollution in more ways than one, composting and other biological stabilisation processes, which would mitigate the impact of uncontrolled decomposition of organic MSW should be adopted by urban areas. Composting is an environmentally beneficial waste recycling mechanism and not a waste disposal mechanism.

### 3.2.3 BENEFITS OF COMPOSTING

- The real economic benefits of compost use include improved soil quality, enhanced water retention capacity of soil, increased biological activity, micronutrient content, and improved pest resistance of crops.
- Composting minimises or avoids GHG emissions from anaerobic decomposition of organic waste (such as in a large unturned heap).
- Composting increases the design life of other waste management facilities.
- Stringent design requirements and associated costs for catering to management of leachate from organic waste decomposition may be reduced in those landfills that do not receive organic waste.

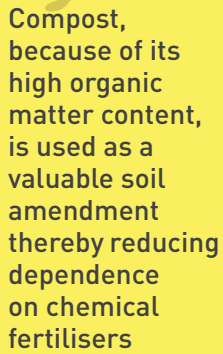

Compost, because of its high organic matter content, is used as a valuable soil amendment thereby reducing dependence on chemical fertilisers

- Compost is particularly useful as organic manure; it contains macronutrients (nitrogen, phosphorous, and potassium) as well as micronutrients. When used in conjunction with chemical fertilisers, optimum results are obtained.
- The use of compost reduces the dependency on chemical fertilisers for agricultural operations. When used as a soil amendment, compost reduces the need for water, fertilisers, and pesticides. Compost acts as a soil conditioner, therefore supporting the long-term fertility of soil.
- Compost may be used to revitalise vegetation habitats and add life to marginal, impoverished soils and waste lands.
- Compost may also be used as a bio matrix in remediation of chemical contaminants and as a remediated soil in contaminated sites; compost helps in binding heavy metals and other contaminants, reducing leachate and bio-absorption.

### 3.2.4 NEED FOR MARKET IDENTIFICATION AND ANALYSIS



SWM Rules, 2016 lays emphasis has been on market development through appropriate mechanism.

**Clause 7: Duties of Department of Fertilisers, Ministry of Chemicals and Fertilisers:-**

- (1) The Department of Fertilisers through appropriate mechanisms shall-
  - (a) provide market development assistance on city compost; and
  - (b) ensure promotion of co-marketing of compost with chemical fertilisers in the ratio of 3 to 4 bags: 6 to 7 bags by the fertiliser companies to the extent compost is made available for marketing to the companies.

**Clause 8: Duties of Ministry of Agriculture, Government of India.- The Ministry of Agriculture through appropriate mechanisms shall-**

- (c) set up laboratories to test quality of compost produced by local authorities or their authorised agencies; and
- (d) issue suitable guidelines for maintaining the quality of compost and ratio of use of compost visa-a-vis chemical fertilizers while applying compost to farmland.

The financial viability of compost plants is primarily dependent on the marketability of the compost at a reasonable price. For the low carbon soil (soil organic carbon) prevalent in India, there is a huge requirement of good quality compost for agriculture. Yet the present



demand for compost is very low. An analysis of the available markets and potential demand for compost is essential to decide the required size of the compost plant. An assessment of end user requirements of compost quality, as defined by the final use, is essential to arrive at the final design of the compost plant.

Market development for compost and proper quality monitoring are crucial. The following strategies can be applied for market development:

- The pricing mechanism for sale of compost should be assessed. Each state government should fix a minimum retail price for compost, which meets Fertiliser Control Order (FCO) 2009 standards, to ensure economic viability of these plants.
- All state and local government departments should be encouraged to promote the use of compost in parks, gardens, nurseries, and urban forestry projects.
- Apart from FCO compliant compost, a line of value-added compost may be developed by adding additional nutrients. One such example is phosphate rich organic manure (PROM), which may be used as replacement of chemical phosphatic fertilisers such as di-ammonium phosphate (DAP) and single superphosphate (SSP).
- Co-marketing of compost made from city garbage with chemical fertilisers in the ratio of 3–4 bags: 6–7 bags is suggested by the SWM Rules, 2016 and the Inter-Ministerial Task Force on Integrated Plant Nutrient Management (IPNM), vetted by the Supreme Court of India in 2006.
- The benefits of compost should be informed to farmers, who should be encouraged to partially substitute inorganic fertilisers with organic compost, as appropriate for their crop and specific soil.
- Opportunities for involving agricultural officers to generate awareness of compost usage among farmers should be looked into.

Both physical and chemical properties of the finished compost are to be considered. Decisions on pricing of the compost should be based on the size and location of markets. The distance to which the finished product may be transported will have a strong bearing on the landed price of compost.

An assessment of competing compost suppliers is also essential, especially in cases where it is estimated that the compost will need to be marketed beyond the vicinity of the plant.

An analysis of market demand for compost and its potential end-use determines the design, capacity and hence the financial viability of compost plants

Co-marketing of compost with chemical fertilizers by the fertiliser companies as a “Basket Approach” was recommended by Inter-Ministerial Task Force on IPNM (2005)

Successful market for compost depends on two major factors:

- producing consistent quality and quantity of compost
- identification of potential users



Pre-sorting and segregation of MSW is a pre-requisite for maintaining the quality of the compost produced



### Analysis for Marketing Compost

- How much compost will your plant produce?
- Where will the compost be used and for what?
  - Do you realize the importance of consistent quality control for building and maintaining the brand image of your compost?
- Does your plant have the necessary process flow and equipment to produce compost which is compliant with the relevant rules (e.g., FCO 2009, 2013)?
- Who are your potential customers? Consider the number of compost plants and quantity of compost produced in the state, while assessing the size of the potential compost market.
- What is the typical quality of compost required by the different categories of consumers?
- How much are your consumers willing to pay for the compost?
- Identify competing products for identified consumer uses and their prices.
- Identify compost transportation requirements and costs.
- Develop a marketing strategy.
- Relook at the size of the proposed compost plant and the size of the potential compost market.

#### 3.2.4.1 CONSTRAINTS FACED BY THE COMPOSTING SECTOR IN INDIA

Composting of MSW started in the late 1970s when some mechanical compost plants were set up across the country. The concerned ULBs were the owner and operator of the compost plants. These facilities were replica of plants from the industrial countries without the necessary adaptation exercise; consequently, these capital-intensive facilities were heavily mechanised and faced maintenance problems. An evaluation of the mechanical compost plants was carried out by the National Environmental Engineering Research Institute (NEERI) during 1980–1982. Since the input garbage was mixed and the design was not adequate for removal of non-compostable fractions quality of the final product was poor, leading to lukewarm response from the market and poor unviable price.

The scenario changed in the early 1990s with the entry of the private sector—equipment fabricators, plant operators, etc. Mechanisation was reduced by almost eliminating the pre-processing stages (for e.g., the mechanical compost plant of the Municipal Corporation of Delhi, established in 1981). The machinery and equipment manufacturers introduced equipment at the post-screening stages, such as trommels with finer screen, air density separator (de-stoner), etc. to improve the quality of compost by better removal of small contraries, such as pieces

of glass and plastics, grit, coarse sand, etc. Bio-inoculum was sprayed over the windrows for suppressing bad odour. In the initial years, there were reports of good price of compost, leading to reported commercial viability. In the later years, the euphoria was replaced by the realisation that the good price belonged to the niche market of plantations and some cash crops. And with more and more operating plants, the bulk of the compost had to be sold to the farmers, who could not afford it.

The sector at present faces the following constraints:

- i. compost quality standards (SWM Rules, 2016 and FCO series) are becoming increasingly stringent;
- ii. majority of the collection of MSW is in the form of mixed waste;
- iii. making quality compliant compost from mixed waste requires some equipment for refinement and quality control and higher production cost, but the yield is reduced as the quality standards are higher (10%–15%);
- iv. all compost sold for application to food crops is mandated to be FCO compliant;
- v. percentage of process rejects increases proportionally (30%–40%) unless the processing facility produces compost as well as refuse derived fuel (RDF);
- vi. lack of knowledge and practical experience among the various stakeholders responsible for planning, execution, operation and maintenance (O&M), and marketing leads to inadequately designed plants, inefficient equipment, improper operation, and shortcuts from equipment design to operational protocol;
- vii. after the product is ready (called “finished compost”), cost is incurred for bagging, transport, marketing (commission of the chemical fertiliser company, dealers, etc.). The final cost to the farmer is normally almost twice the price received by the compost plant operator;
- viii. as of 2015, the total cost to the farmer is about Rs.4,000–Rs.5,000 per ton of finished compost (distance being the main price variant). This price is too high for the average farmer;
- ix. the long-term benefits of soil conditioning properties of compost are not adequately appreciated by the farmers and other stakeholders.

### 3.2.5 THE COMPOSTING PROCESS – PHASES AND CRITICAL PARAMETERS

Figure 3.9: Process of Aerobic Composting<sup>13</sup>

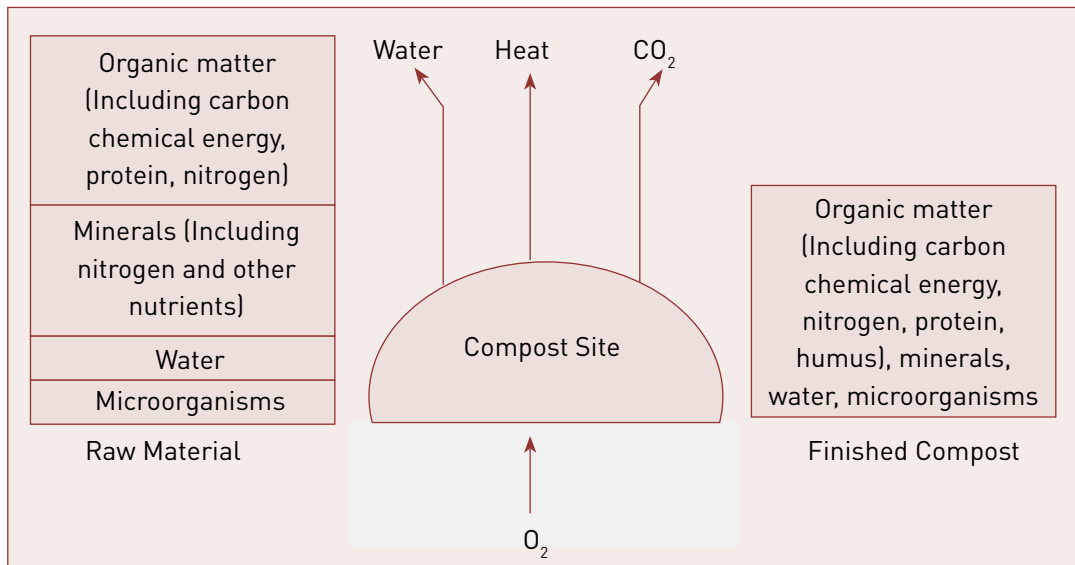

During aerobic composting, microorganisms oxidize organic compounds to carbon dioxide (CO<sub>2</sub>), nitrite, and nitrate. Carbon from organic compounds is used as a source of energy while nitrogen is recycled. Due to chemical reactions producing heat, temperature of the mass rises.

Several biological, chemical, and physical processes contribute to the success of the aerobic composting (Figure 3.9). Understanding these processes is necessary for making informed decisions when developing and operating a composting plant.

#### 3.2.5.1 BIOLOGICAL PROCESSES

The process of aerobic composting passes through two distinct stages of high significance: thermophilic stage (sanitisation) and mesophilic stage (decomposition).

Different organisms are known to play a predominant role in breaking down biodegradable constituents of MSW. The majority of microorganisms responsible for composting are already present in MSW. A succession of microbial growth and activity among the bacteria, fungi, actinomycetes, yeasts, etc. takes place during the process, whereby the environment created by one community of microorganisms encourages the activity of a successor group. Different types of microorganisms are therefore active at different times and locations within the windrow depending upon the availability of substrate, oxygen supply, and moisture content of the organic matter.

The two distinct biological process stages observed during composting are:

- thermophilic stage
- mesophilic stage

13 On-Farm Composting Handbook. Rynk, R., et al. 1992. Ithaca, New York: PALS Publishing Cooperative Extension.



### (i) Thermophilic Stage (Sanitisation)

This is the first phase of composting wherein microorganisms decompose the easily degradable organic substances producing heat as a result of intense metabolic activity. In most cases with moisture content of 55%–60% and air voids of 20%–30% in the windrow, a temperature rise from 35°C to 55°C–65°C is achieved within 2–3 days.

- typically, thermotolerant fungi, thermophilic bacteria, and actinomycetes are the predominantly active microorganisms at this stage.
- windrows are turned at regular intervals to expose the material in the inner core to air so that temperature in these fresh sections rise again, and gradually the whole windrow is sanitised from pathogens.

### (ii) Mesophilic Stage

- in the second stage, due to reduction in available nutrients and readily available carbon, the microbial activity reduces, causing a decline in the temperature of the heap. There is a shift in the type of active microbial species in the compost heaps.
- the composted material becomes dark brown during this stage due to humus synthesis and starts to stabilise

### (iii) Curing Stage

- Curing of compost is done after the material from the windrow is screened. The screened material is then allowed to mature in the curing stage. This is a very important phase in the composting process. Microbial species degrading complex polymers, such as cellulose, lignin, and hemicelluloses, increase drastically during this phase.
- Bacteria represent 80% of this population. Free living nitrogen-fixing bacteria, denitrifiers, sulphate reducers and sulphur oxidizers are important constituents of the total microbial population.

## 3.2.5.2 CHEMICAL PARAMETERS

- (i) **Moisture:** Moisture is a critical factor in establishing stable conditions conducive for composting because the microbes need moisture for survival and growth. Moisture tends to occupy the free air space between the decomposing particles. Hence, when the moisture content is very high, anaerobic conditions set in.
- (ii) **Aeration:** The composting process requires adequate supply of oxygen for biodegradation by microorganisms. Under aerobic conditions, decomposition rate is 10–20 times faster than under limited oxygen supply or anaerobic conditions.

**Thermophilic Stage:**  
Moisture: 55%–60%  
Temperature: 55°C– 65°C  
Air voids: 20%–30%  
Microorganisms: thermotolerant fungi, thermophilic bacteria, actinomycetes

**Mesophilic stage:**

- temperature: moderate
- stabilisation of compost material

**Curing:**

- Maturation Stage
- Lasts for 3–4 weeks
- Microbial species population increases drastically

Compost pile should have enough void space to allow free movement of air as aerobic conditions fasten the composting process by 10–20 times and reduce generation of foul smell

C/N ratio of 30:1 is ideal for decomposition. C/N ratio below 25:1 results in foul smell while higher C/N ratio impedes decomposition

Temperature plays a critical role in composting by increasing rate of biological activity resulting in faster stabilisation

High oxygen levels in air voids are maintained within waste piles or windrows through turning and mixing at regular intervals. In static piles, anaerobic conditions may be created due to the utilisation of available oxygen by microorganisms and production of CO<sub>2</sub> during decomposition of the waste. This could result in a buildup of anaerobic microorganisms, resulting in foul smell.

### (iii) Carbon-to-Nitrogen Ratio

- MSW in India has an initial carbon-to-nitrogen (C/N) ratio of around 30:1, which is ideal for decomposition. The organisms involved in stabilisation of organic matter utilise about 30 parts of carbon for each part of nitrogen. C/N ratio below 25:1 results in production of foul smell and a higher C/N ratio will result in impeding the decomposition process.
- Whenever the C/N ratio is less than the optimum, carbon source such as straw, sawdust, paper are added.
- Higher C/N ratios may be reduced by adding biodegradable material having high nitrogen content, such as non-edible oil cakes, green biomass, etc. It is not preferable to add slaughter house waste to MSW waste piles, as they require specific closed systems or in-vessel systems.

### 3.2.5.3 PHYSICAL PROCESSES

- (i) **Temperature:** Under properly controlled conditions, temperatures are known to rise beyond 70°C in aerobic composting. This increased temperature results in increased rate of biological activity, resulting in faster stabilisation of the material. However, if the temperature rise is very high, due to inactivation of the organisms and enzymes, the rate of activity may decrease.

High temperature also helps in destruction of some common pathogens and parasites. Ambient air temperatures have little effect on the composting process, provided the mass of the material being composted can retain the heat generated by the microorganisms under aerobic condition. If the process is so controlled that the temperature is kept at 55°C or above for at least 3 days, destruction of pathogens and parasites can be ensured.

- (ii) **Particle Size:** The optimum particle size should have enough surface area for rapid microbial activity, but also enough void space to allow air to circulate for microbial respiration. The feedstock composition can be manipulated to create the desired mix of particle size and void space.

### 3.2.6 MUNICIPAL SOLID WASTE FEEDSTOCK FOR COMPOSTING

The segregated wet fraction of MSW (comprising mainly biodegradable waste), vegetable market waste, and yard waste is the preferred feedstock for compost plants. However, where door-to-door segregation of dry and wet fractions is not practiced, it is possible that mixed MSW reaches the plant. In such instances, pre-sorting and segregation of the organic fraction from the mixed fraction is a critical step in ensuring adequate quality of the processed compost. Presence of contaminants hampers the activity of the microbes and reduces the final quality of compost; it is essential to keep street sweepings and drain cleaning material out of the feedstock, which is a major source of contaminants. This can be done through organisational arrangements in the ULB. Street sweepers should not mix their waste with MSW collected from households and establishments.

MSW feedstock should be delivered at a well-defined area within the plant. This area is essential for overall smooth functioning and regulated flow of MSW feedstock into the processing area. The tipping area should have adequately sized shed (sides open) to receive predetermined quantities of waste daily. Unregulated storage of waste should be avoided. Garland drains leading to a leachate collection tank connected to the leachate treatment system are essential at the tipping floor. Bulky items like bed mattress, tires, large pieces of fabric (e.g., sarees) and thin plastic film, large toys, pieces of asbestos, fibre reinforced plastic (FRP), branches of tree, etc. have to be pulled out before the waste moves on to the pre-sorting section.

In large plants receiving above 300 TPD of MSW, some designers prefer to provide a shallow pit to increase the volumetric capacity within the same footprint. However, in warm countries, pits may cause odour problem if it is not emptied regularly and if leachate is not pumped out every day and the pit is not thoroughly cleaned occasionally.

Under certain conditions, buffer storage may be required:

- High floating population—places of tourism and religious importance
- Festive occasions or large gatherings—rallies, meetings, etc.
- No uniform collection and transportation on a daily basis, clearing of a backlog, etc.

However, such buffers should be planned very carefully mainly because holding raw waste for more than a day attracts vectors, causes odour nuisance, and leachate. Therefore, such buffer areas should be planned only if it is essential due to the above conditions and should not normally be more than one day. Instead, it would be more convenient to build additional capacity in pre-sorting line and compost pad area.

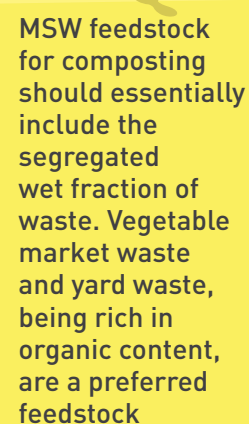

MSW feedstock for composting should essentially include the segregated wet fraction of waste. Vegetable market waste and yard waste, being rich in organic content, are a preferred feedstock

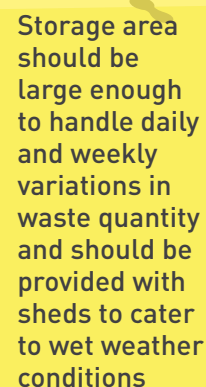

Storage area should be large enough to handle daily and weekly variations in waste quantity and should be provided with sheds to cater to wet weather conditions

The compost pad and the curing area for semi-finished compost are the most convenient buffer areas.

### 3.2.7 PRE-PROCESSING OF MIXED MUNICIPAL SOLID WASTE

Typically, mixed MSW received at the compost plant consists of 40%–50% non-biodegradable material. Pre-processing of mixed MSW is crucial for preparing FCO-compliant compost. In case source segregated waste or dedicated waste from fruit and vegetable market is received, pre-sorting can accordingly be minimal and therefore the capital and O&M cost are less and the yield of compost is higher than in the case of mixed waste. Pre-processing serves the following purposes:

- separation of the mixed material into different streams, which are suitable for specific products—biodegradable for composting, combustible dry material for RDF, separation of recyclable material on sorting belt (glass, metal, etc.); and
- reduction of cross-contamination of the material to make different products.

The pre-processing section is designed on the basis of average composition of the incoming waste, quantity, space available for pre-sorting, and whether only composting or a combination of compost and RDF is targeted. Following Figure 3.10 illustrates the various steps involved in pre-processing of mixed MSW.

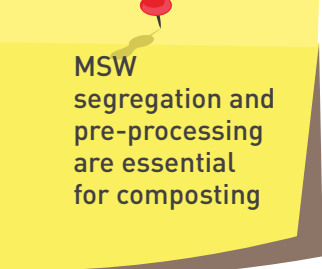

MSW segregation and pre-processing are essential for composting



Pre-processing has a high economic value as it recovers recyclables, reduces contaminants, lowers processing costs and also ensures quality of compost



**Figure 3.10: Pre-processing of Mixed Municipal Solid Waste<sup>14</sup>**

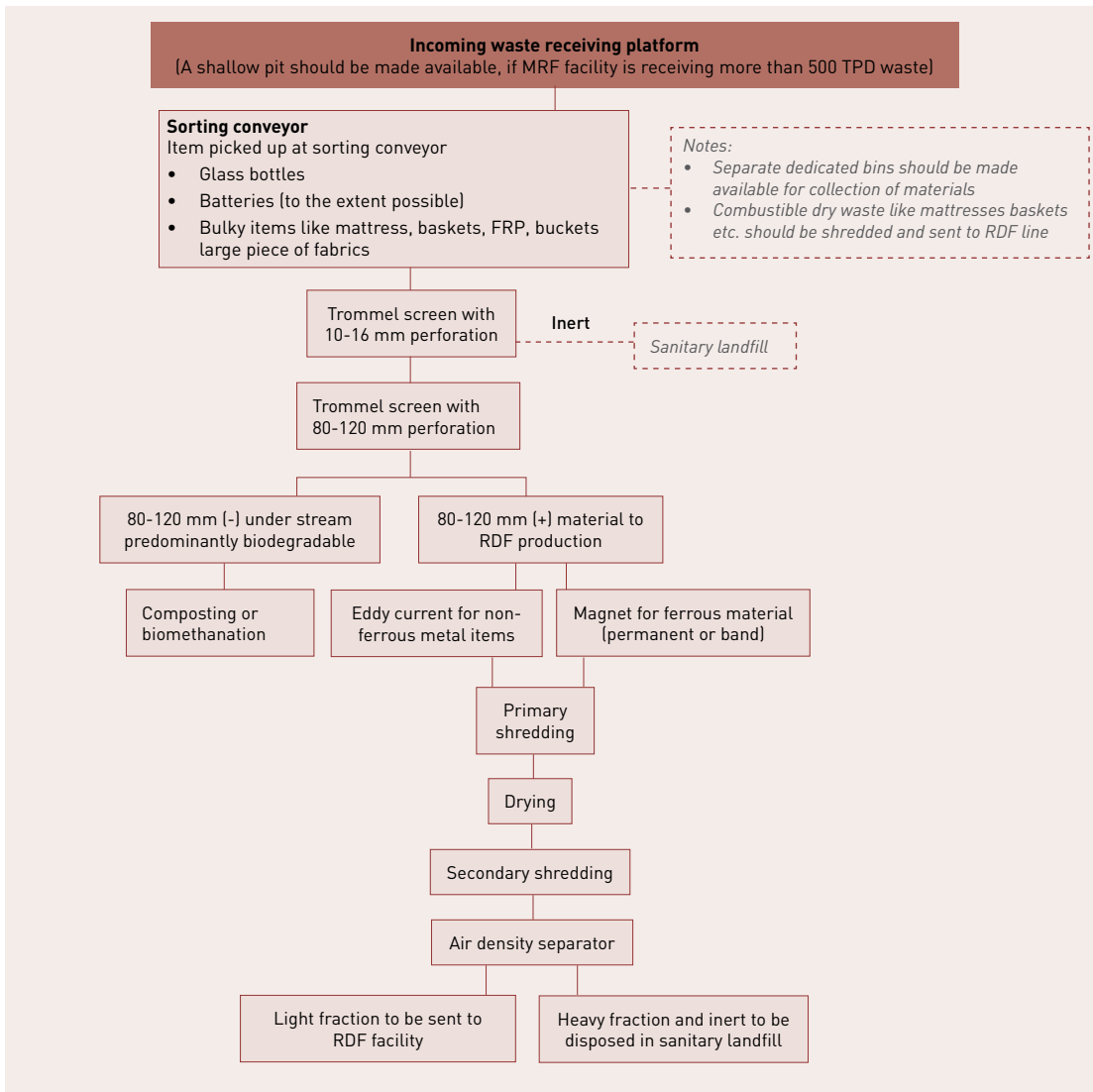

**Sorting:** The level of sorting feedstock depends on several factors including the source of feedstock, the end use of the product, and the operations and technology involved. Sorting in a well-designed compost or RDF plant consists of hand sorting on a sorting belt, followed by mechanical sorting in one or more trommels. Mixed waste is fed onto a slow-moving (5 m per minute) conveyor belt. Items not suitable for the trommel, such as glass bottle, metal container, any hazardous material like containers of paint, etc. are taken out by hand and put in appropriate bins. The workers should be provided with gloves to avoid injury. The thickness of the moving waste pile on the conveyor belt should be less than 15 cm (for better manual sorting) and the removed material stored in segregated vats or large containers. This is usually recyclable material or material with high calorific value, which can be further processed to recover the energy content. Metals are then removed from the waste by either a suspended magnet system or a magnetic pulley.

Sorting results in recovery of recyclable material with high calorific value

14 Developed by the Expert Committee for revision of MSWM manual (2013-15).

Remaining mixed waste is subjected to mechanical separating devices such as a segregating trommel, where material passing through the screen (80–100 mm) is utilised for compost production. An additional trommel of 200 mm screen may be required as an add-on for plants with a capacity of over 500 TPD of waste, which is placed before the trommel with 80–100 mm apertures.

The purpose of a trommel is to segregate materials on the basis of size through cascading action. For effective segregation, it is necessary that the material undergoes sufficient number of turns inside the trommel and, at the same time, gets sufficient fall depth for good cascading action. Therefore, the length and the diameter of the trommel are very important. Normally for MSW, a trommel with a length of 10 m and a diameter of 2.5 m and above would be desirable. At the same time, there should be no axle passing through the trommel in the middle; the drive for the trommel has to be external.

Table 3.3 outlines mechanical separation technologies that are currently used in MSW composting. Details of these processes are discussed below.<sup>15</sup>

**Table 3.3: Pre-processing: Sorting of Mixed Municipal Solid Waste Feedstock**

| TECHNOLOGY              | MATERIALS TARGETED                |
|-------------------------|-----------------------------------|
| Screening               | Plastics, paper, cardboard, metal |
| Magnetic separation     | Ferrous metal                     |
| Eddy current separation | Nonferrous metal                  |
| Ballistic separation    | Plastic, paper, glass, gravel     |

**Pre-processing technologies:**

- Screening-controls the size of feedstock
- Magnetic separation-removes ferrous metals
- Eddy-current machines-separates aluminium and other non-ferrous metals
- Air classifiers-removes heavier fractions like glass and ceramics

**Screening:** Screens are used to control the size of feedstock. They separate small dense material such as food scrap, glass, and plastics from the bulky light fraction of the feedstock. Trommel screens are commonly used for initial material processing at MSW facilities.

**Magnetic separation:** Magnetic separators create magnetic fields that help in removing ferrous metals from the feedstock as it travels along conveyors. The efficiency of magnetic separators depends primarily on the quantity of materials processed and the speed at which they pass through the magnetic field.

**Eddy current separation:** Eddy current machines separate aluminium and other non-ferrous metals from MSW. These machines generate a high energy electromagnetic field that induces an electrical charge in non-ferrous metals and forces these materials to be repelled from non-charged fractions of the feedstock material. The feedstock should be conveyed to eddy current machines after magnetic separation to

<sup>15</sup> *Composting Yard Trimmings and Municipal Solid Waste*. United States Environmental Protection Agency, 1994 Washington, DC.



minimise contamination by metals. Eddy current machines are not usually used in India, since metals are not usually found in waste.

**Air Classifiers:** Air classifiers separate feedstock material based on density differences, i.e., the heavier fractions (metals, glass, ceramics, etc.) are removed from the lighter materials. The heart of an air classification system is an air column or throat into which the materials stream is fed at a specified rate. A large blower sucks air up through the throat, carrying light materials such as paper and plastic or fine dry compost, which then enter a cyclone separator where they lose velocity and drop out of the air stream. Heavy materials fall directly out of the throat or column.

**Ballistic separation:** Ballistic or inertial separation separates constituents based on density and elasticity differences. This can be applied for segregating materials on compost stream or RDF stream. However, it is more suitable for RDF stream for separating grit and other heavy inert material. Compost feedstock is dropped on a rotating drum or spinning cone, and the resulting trajectories of glass, metal, and stone, which depend on density and elasticity, bounce the material away from the compost feedstock at different lengths.

**Additional inoculum:** Inoculum (bacterial culture) is also added to the feedstock to improve efficacy of the process.



#### Indicative Equipment Required for Pre-Processing

- **Loader:** Tractor mounted front-end loaders or pay loaders are used to deliver the raw feedstock to conveyors. These vehicles have a shovel-like attachment at the front of the machine which can be raised by a hydraulic mechanism to lift feedstock material and release material onto the conveyors or into piles.
- **Conveyors:** Conveyors are mechanical systems with belts that slowly pass over rotating wheels. Conveyor belts are used in the sorting or separation phase of composting to facilitate manual removal of non-compostable material. The width of the conveyor belt should be narrow enough for workers to reach its centre.
- **Screens:** Screens are primarily used for separating large material from the feedstock. Different screens used are the following:
  - **Trommel screens:** Long, cylindrical screens are placed at an angle to facilitate material movement through the perforated screen. Material smaller than the grate fall through and material with larger diameters than the grate pass through the trommel. As the trommel screens rotate, a brush is passed over the top of the screen to remove lodged materials and prevent clogging of the screen.
  - **Rotary screens:** Feedstock is loaded onto spinning, perforated discs in this system. Oversized material are scattered from the screen because of the

Adding inoculum may be an issue because of its cost implications. However, inoculum enhances composting process and also helps in suppressing foul odour

spinning action. Undersized material fall through the perforations in the discs. However, trommels are preferred for better performance and cleanliness.

- **Magnetic recovery systems:** With these systems, a magnetic field removes ferrous metals from the rest of the feedstock material. The following types of magnetic separators are commonly used:
  - **Overhead belt magnets:** Cylindrical magnets are installed over a conveyor belt which carries feedstock and separates out ferrous materials.
  - **Drum magnets:** Drum magnets are placed over a conveyor belt; ferrous metals in the feedstock that pass under the rotating drum are attracted to the magnet and stick to the drum.

### 3.2.8 COMPOSTING TECHNOLOGIES

Technologies for composting can be classified into the following general categories:

- windrow composting;
- aerated static pile composting;
- in-vessel composting;
- decentralised composting (bin and box composting); and
- vermicomposting.

#### 3.2.8.1 WINDROW COMPOSTING

Windrow composting process consists of placing the pre-sorted feedstock in long narrow piles called windrows that are turned on a regular basis for boosting passive aeration. The turning operation mixes the composting materials and enhances passive aeration. Figure 3.11 gives an overview of the windrow composting process although the figures presented may vary with the characteristics of the waste, design of the plant, and the rigorousness with which the standard operating process is followed. Compost yield of 10-15% is more common from mixed municipal solid waste.

#### 3.2.8.2 KEY PERFORMANCE INDICATORS FOR WINDROW COMPOST PRODUCTION

Figure 3.11 depicts a process flowchart for a 500 TPD plant, indicating 20% process efficiency. While 20% efficiency is possible under good operational conditions, the typical efficiency of a windrow compost plant receiving segregated organic solid waste is around 18%–20%, i.e., for an input feedstock of 100 TPD of segregated waste, it should be able to produce 18–20 tonnes of finished compost. Where mixed waste is received as input feedstock, compost yield of 10%–15% is expected.

**Figure 3.11: Process Flowchart and Mass Balance for Aerobic Windrow Composting of 500 Tonnes Per Day of Waste<sup>16</sup>**

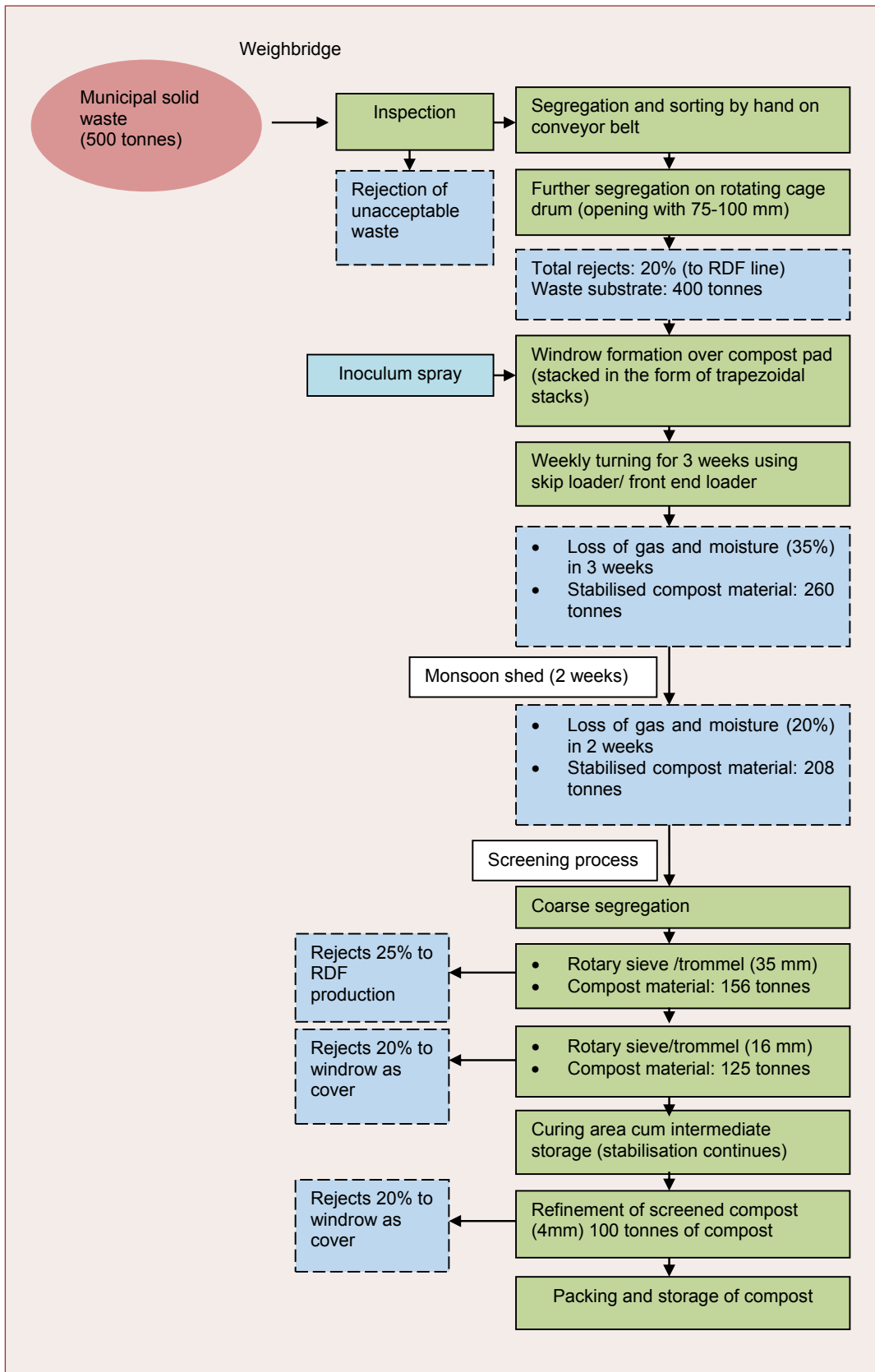

16 "Composting Municipal Solid Waste: the Indian Scenario", Mazumdar, N. (2007), International Journal of Environment Technology and Management. 7 (3-4).

### 3.2.8.3 UNIT OPERATIONS IN WINDROW COMPOSTING

Compost pad should be impervious, have a drainage system to collect leachate for treatment and have an appropriate gradient to route the leachate to the collection point

Compost pad (platform): The pre-processed MSW (Section 3.2.7 of Part II) is transferred onto the compost pad into windrows. The compost pad is an area where the windrows are stacked. The compost pad must be stable, durable, and impervious, so it is constructed with an appropriately designed combination of reinforced cement concrete (RCC) and plain cement concrete (PCC). The compost pad shall have a slope of about 1% to drain the excess water (storm water or leachate) from the windrows into a leachate collection tank. The leachate tank is placed in the lowest corner of the compost pad area. This leachate should be reused for recirculation of nutrients and for maintaining the moisture content of windrows. Figure 3.11 describes unit operations in windrow composting.

The following factors have to be considered in the location and design of the composting pad:

- The base has to provide a barrier to prevent the percolation of leachate and nutrients to the subsoil and groundwater.
- The surface has to facilitate equipment movement even during wet weather conditions.
- The surface area has to accommodate waste for 5 weeks, with sufficient room for equipment to maneuver and an area to establish a static pile for curing compost.

The height to base width ratio of the windrow depends basically on the angle of repose of the material. Windrows are typically trapezoidal in cross section.

The space between windrows should be sufficient for movement of the windrow turning machine. Normally, it is 1–3 metres. Figure 3.12 below illustrates calculation of windrows sizes. Detailed designing and area required for compost pad is given in Annexure 4.

Windrow composting is the most economical and widely accepted composting process



In general, as the average windrow shape is between an oval and trapezoid, a factor of 0.66 is assumed to estimate windrow volumes. Therefore, the equation for volume of the windrow is:  $\text{Volume} = \text{height} \times \text{width} \times \text{length} \times 0.66$ .

Figure 3.12: Windrow Sizing Calculations<sup>17</sup>

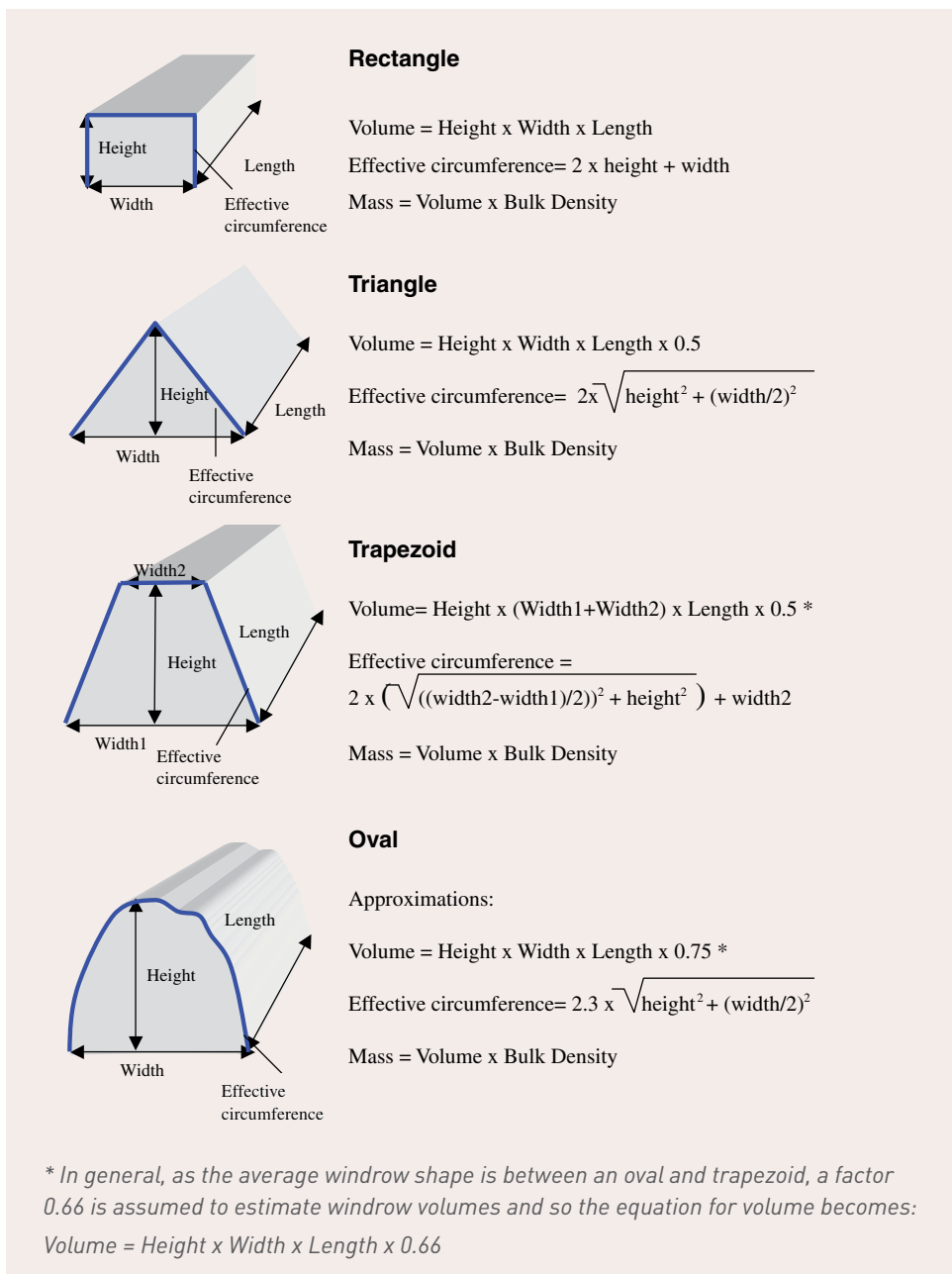

Size, shape and spacing of windrows depend on turning practices:

- Bucket loaders: high windrows
- Turning machines: low and wide windrows
- Manual labour: small scale windrows

**Windrow Formation:** The size, shape, and spacing of windrows depend on the equipment used for turning. For example, bucket loaders are used to build high windrows, whereas turning machines create low and wide windrows. Manual labour is also used for windrows of a smaller scale, where additional equipment costs and use of machinery are not feasible.

**Windrow Turning:** Windrows are turned frequently to maintain aerobic conditions inside the pile. Windrow turning is a mechanised operation. Generally, pay loaders (wheel or tracked) or tractors with hydraulic

Windrow dimensions should allow conservation of heat generated during composting process while also maintaining diffusion of air to the deeper portions of the windrow

17 Compost Facility Operator Manual; Available at: <http://www.transformcompostsystems.com/pdfs/Transform%20Compost%20Operator%20Manual%20teaser.pdf>



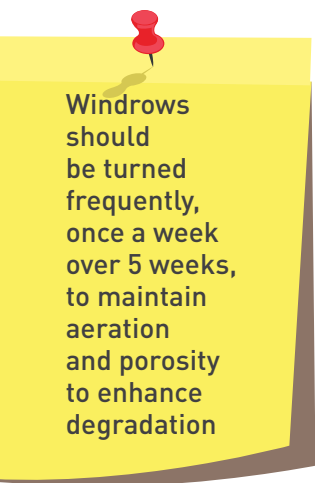

Windrows should be turned frequently, once a week over 5 weeks, to maintain aeration and porosity to enhance degradation

attachments are used to scoop the material from one windrow to make a new pile in an adjacent location on the compost pad, while placing and mixing the material. Other equipment such as front-end loaders or windrows re-shifters may also be used for turning windrows. Windrow turning ensures that outer layers of piles are moved to inner layers. This process is repeated once every week for 5 weeks; high temperatures within the windrow (55°C–65°C) sanitise the material. During the rainy season where the interstitial spaces are filled with water, more frequent turning is necessary (interval of 3–4 days).

Regular turning of the windrows helps oxygenate the pile; breaks up particles to increase surface area; improves the porosity to prevent settling and compaction; and allows trapped heat, water vapour, and gases to escape. In general, the more frequently a pile is turned, the more quickly the composting process is completed. However, too frequent turning has two disadvantages: (i) formation of heated pile in the core area being hampered (necessary for pathogen kill), and (ii) additional costs resulting from equipment and associated energy use. A balance is therefore to be achieved between number of turnings and cost of production.

A turning schedule should be established based on the rate of decomposition, moisture content, porosity of the material, and the desired composting time (often a function of land availability). Normally, once a week turning is done but more frequent during rainy season (once in 3–4 days).

In general, each windrow should be allowed to stay on the compost pad for 35 days; at the end of the 35<sup>th</sup> day, the compost is ready for use. Each windrow should have a flag board depicting the age of the waste. Fresh incoming waste is always depicted as “Age 1.” The numbering on the windrow changes from Age 1 to Age 2 on the second day, Age 2 to Age 3 on the third day, and so on. Each windrow may be turned manually or mechanically. This turning process has to be done every 7<sup>th</sup> day. Hence, only those windrows having a flag board showing Age 7, 14, 21, and 28 should be turned.

Figure 3.13 below illustrates an indicative arrangement of windrows. Incoming waste on day 1 is placed in pile A1. Waste that comes in on day 2 is placed in pile A2, waste on day 3 in pile A3, and so on. On the 7<sup>th</sup> day after receiving the first batch of waste A1, the pile or windrow is turned or mixed, and the pile is moved to location B1. On the 14<sup>th</sup> day, pile B1 is turned or mixed and moved to C1, and so on. Pile D1 will therefore be moved to E1 on the 28<sup>th</sup> day. On the 35<sup>th</sup> day, the compost pile from E1 should be screened for further refinement. Each of the piles or windrows A2 to A7 are managed similarly. Waste that is received on 8<sup>th</sup> day is placed in the initial location of pile A1, since this pile would

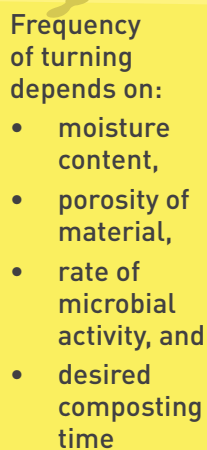

Frequency of turning depends on:

- moisture content,
- porosity of material,
- rate of microbial activity, and
- desired composting time



already move to B1 on the 7<sup>th</sup> day, hence this location would be free to receive a new pile or windrow.

**Figure 3.13: Arrangements and Turning of Windrows<sup>18</sup>**

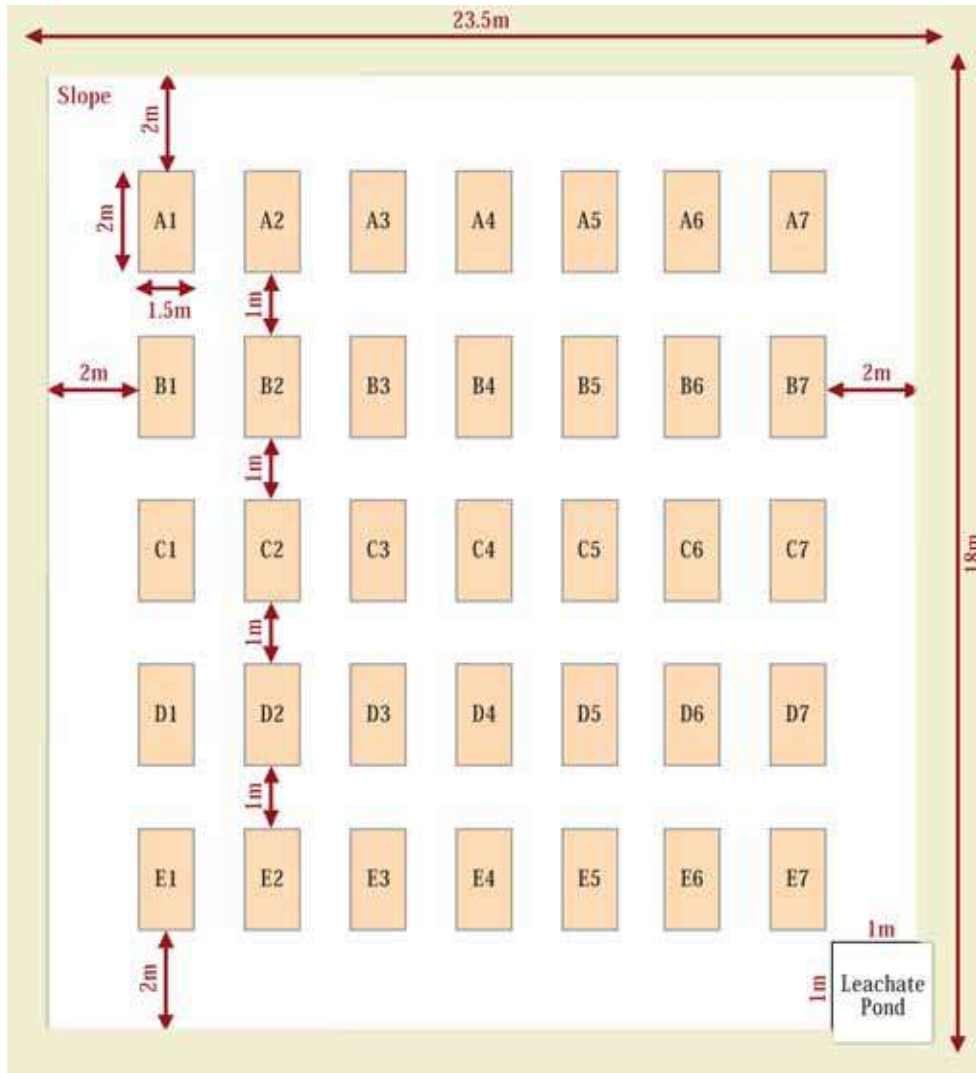

Fresh water or leachate stored in the leachate tank should be sprinkled during the turning process to maintain the moisture content of the waste. Figure 3.14 depicts a quick and simple method to test moisture content.

18 IEC brochure for windrow composting, GIZ (2012).

**Figure 3.14: Squeeze Test to Estimate Moisture Content<sup>19</sup>**

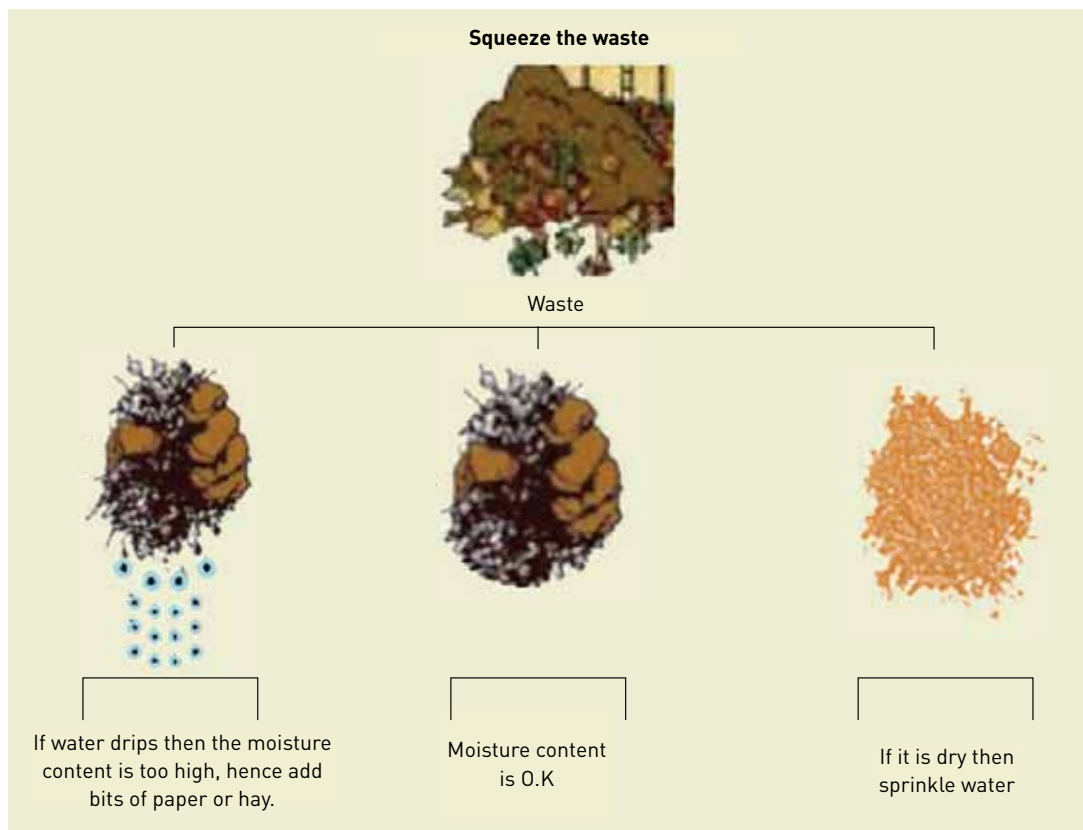

Temperature should also be monitored and maintained within 55°C–60°C. This is important because low or high moisture and variation in temperature can slow down the composting process.

On the 35<sup>th</sup> day, the compost is successively sieved through two stage screening system of 35 mm followed by 16 mm. Screened material coming out of this section is uniform in texture but contains semi-solid organic compost, which requires further stabilisation. The rejects from the 35 mm screen are sent to the RDF and the screened material is sent to the 16 mm screen. The rejects from the 16 mm (16 mm+) screen are to be put back on the windrow as protective covering from bird menace and vermin, and for odour control, as illustrated in Figure 3.11.

**Curing:** Screened material coming out of the coarse segregation section requires further maturation and moisture control for producing a product that is beneficial for plants and soil. The degree of maturity is determined through either oxygen uptake or CO<sub>2</sub> production rate.

Maturity may also be determined through a simple test, wherein the material is placed in a plastic bag and moistened to 60% water content, the mouth of the bag is then closed. The plastic bag containing the moist material is allowed to sit for 24–48 hours at room temperature (30°–35°C). If foul odours are released when the bag is opened at the end of

Curing of screened material for at least 3 weeks in a covered area ensures complete maturation of compost

<sup>19</sup> IEC brochure for windrow composting, GIZ (2012).



24–48 hours, it indicates that the material is not fully matured and needs to undergo further decomposition.

The cured material does not release odours because of carbon stabilisation during aerobic decomposition of biodegradable material in the windrow. Microbial activity continues during the curing phase also, but at a lower rate compared to the main composting phase.

Nevertheless, also during curing, the supply of adequate oxygen is ensured through passive movement of air through the pile and moisture content is maintained within 25%–30%. The curing piles are placed either in a storage area or covered area for a minimum duration of 2 weeks. In general, the area needed for the curing process is one quarter of the size needed for the windrow or composting process. The completely cured well-composted material does not release foul odour and is ready for final screening and for the preparation of the finished product for marketing.

**Compost Refinement:** At the end of composting phase, the material usually contains 30%–35% moisture. The composting is normally taken to be complete when the active decomposition stage is over and the carbon-to-nitrogen (C/N) ratio is around 20.

The refinement section also consists of a feeder conveyer and a trommel with 4 mm perforations. The screened product less than 4 mm is passed through air density separator (ADS) or de-stoner to remove sand and grit. Then the compost can be put in bags and stored for sale. The remaining material greater than 4 mm should be put on top of the fresh incoming waste heap to speed up the process of composting and for absorbing excess leachate. The residue material from the ADS is inert laced with fine organic material. This should be kept out of the composting stream. This material can be used for landscaping.

The finished product is dark brown with an earthy smell, fragile, and rich in organic matter content and nutrients.

Value-added product can be produced depending on the market demand by enriching compost with beneficial microorganisms and nutrient sources such as rock phosphate, pyrite, etc. The product is bagged and dispatched for marketing to be used on farmer's fields.

Based on the desired end use, the compost should comply with specifications of the Fertiliser Control Order (FCO), 2009 & 2013 and SWM Rules, 2016.



**Bruhat Bengaluru Mahanagara Palike (BBMP)** has proactively set up 7 new processing plants producing compost and crude RDF at several locations through State Government funding and nodal agency KUIDFC. The complete construction has been done by the BBMP and then handed over to private operators for O&M through competitive bidding.

Mature and high quality compost should have a C/N ratio of around 20. Compost with either higher or lower C/N ratio is not beneficial to the soil

Final compost product should be less than 4 mm. Remaining material should be put on the incoming waste heap to hasten the composting process

Figure 3.15: Unit operations in windrow composting<sup>20</sup>



Incoming waste at compost yard

Rain shed

Primary screening

Bagging machine

**Leachate Management:** Leachate is generated during composting as the biodegradable matter is fermented. It is a thick liquid with strong odour with very high biochemical oxygen demand (BOD) and chemical oxygen demand (COD). However, it has moisture and nutrients, which can be put to good use. Leachate can be treated biologically. Control of leachate is a very important part of operating a compost plant safely. But design of an effective treatment for leachate is tricky.

For open aerobic composting windrows, leachate formation is low during non-rainy season, and it can be rolled back into the windrows by placing partially composted relatively dry material around the windrows every day and pushing the absorbed leachate back to the windrows. With a good standard operating procedure (SOP), this is possible and beneficial for composting, as this step puts back some of the nutrients and microbes back into the composting windrows.

During rainy season, depending on the rainfall, the leachate gets diluted with rain water and significant volume is generated, which is beyond the capacity of a leachate treatment plant designed for fair weather. If the design is done for rainy season, the facility is completely under utilised during rest of the year and its cost is very high. For strong

Leachate produced should be collected and used for moistening the waste heap

20 Taken from Nashik Waste Processing Facility, Nashik Municipal Corporation.

leachate, single step treatment may be inadequate. Dilution with fresh water followed by treatment in a stabilisation pond requires large space and is not suitable for places near habitation (possible vector breeding).

In high rainfall areas, it is necessary to cover the windrows either temporarily (using water proof cover) or permanently using sheds which have side cladding at the top with the roof and low wall at ground level but otherwise open from the sides. Great care has to be taken to design the height of the shed because adequate ventilation is necessary. The design has to balance the higher cost of a heavy structure needed for high wind load and the need for adequate ventilation. Due to low height, fully covered windrows in high rainfall areas suffer from slower process and higher moisture leading to difficulty in screening.

Multilayered patented fabric covers are available, which allow moisture to go out (causing odour) but the larger molecules are held back. Such covers can be made a permanent feature, either in the form of direct cover over the windrows or in tent-like formations, within which the compostable material is stacked.

Another efficient way of controlling moisture is by using aerated static pile technology, where there is direct control over aeration and consequently on leachate generation.



#### Typical Equipment Required for Windrow Composting<sup>21</sup>

- **Loader:** Tractor mounted front-end loaders or pay loaders are used to deliver the pre-processed feedstock to form windrows. Loaders are multifunctional and can be used for some other purposes, such as maintaining the site, piling the cured compost, and loading the finished compost product into trucks or trailers for sale.
- **Windrow turner:** Loaders can be used to turn the compost windrows; however, specialised compost windrow turners are much faster and do a better job of mixing the entire windrow. If space is limited at a compost facility site, a loader is a preferred option to make windrows higher and wider. Windrow size need not be limited to suit the specialised compost turners. There are numerous turners available that are dependent on the desired windrow height and width; production capacity; and desired means of operation (self-propelled, loader mounted or pull type, and power take-off driven). Typically, windrows vary from 2 to 3 metres in height and 5 to 8 meters in base width for plants receiving 100 tonnes per day (TPD) or more of waste.
- **Screener:** A trommel screen is desired at the end of the curing process to screen the finished compost for a suitable particle size. This will remove any larger undesirable items and will fluff up the finished product to ensure a suitable compost quality.
- **Bagging:** Bulk supply of compost is usually put in 50 kg bags.

21 Operation Manual for the Establishment of a Commercial Composting Facility, Prepared by Brent Hansen Environmental in co-operation with the City of Brandon, USA; Available at: [http://www.composting.ca/files/op\\_manual.pdf](http://www.composting.ca/files/op_manual.pdf)

### 3.2.8.4 AERATED STATIC PILE COMPOSTING

Aerated static pile technology requires mechanical aeration of composting piles

In the case of aerated static pile composting, forced aeration is used to spread excess air through the windrows unlike the aerobic windrow composting, where aeration is achieved by turning the windrows so that new cut sections are exposed to air. The composting piles are placed over a network of pipes connected to a blower, which supplies the air for composting. Air can be supplied under positive or negative pressure. When the composting process is nearly complete, the piles are broken up for the first time since their construction. The compost is then taken through a series of post-processing steps.

Unlike aerobic windrow composting, the aerated static pile has direct control over aeration. This is the strength of this system, which can be used to reduce the fermentation time and also save precious fuel (diesel) used by the turning equipment. It has also been noted that leachate generation is significantly reduced in case of aerated static pile system.

As compost piles are not turned frequently, feedstock should be mixed with bulking agents like rejects from trommels, straw and wood chips to ensure air circulation

**Preparation of Feedstock:** As the aerated static pile does not receive periodic turnings, the selection and initial mixing of raw materials is critical to avoid poor air distribution and uneven composting. It should be ensured that the feedstock is mixed with a stiff bulking agent such as straw or wood chips. Other possible bulking agents and amendments for static pile composting could include rejects from the 16/14 mm pore size trommels, peat moss, crop residues, bark, leaves, etc.

**Pre-processing:** Aerated static piles can produce excellent compost, provided two basic operating conditions are met:

- The pile of raw material has adequate porosity.
- The airflow system is efficient and provides adequate air flows during the active composting period.

Pre-processing of raw MSW for composting in aerated static pile involves:

- separation and removal of oversize, non-compostable inert materials;
- size reduction through chipping, grinding, or shredding if necessary; and
- blending with composting trommel rejects, wood chips, and other bulking agents to allow proper air distribution.

Detailed pre-processing requirements are discussed in detail in Section 3.2.7 of this chapter.

**Process:** The blended material is placed in stationary or static piles. The piles are constructed above an air source, such as perforated plastic pipes, aeration cones, or a perforated floor. Aeration is accomplished

Pre-processing ensures porosity by removing thin plastics in the raw materials and hence facilitates efficient air circulation

either by forcing or drawing air through the compost pile. It is very important that the pile should be placed after the floors are first covered with a layer of decay-resisting bulking agents such as wood chips or rejects from the 16 mm trommel.

The size of the pile depends on the material to be composted, air flow capabilities, and the type of handling equipment. The initial height of the piles should be about 1.5–2.5 m high, depending on material porosity, weather conditions, and the reach of the equipment used to build the pile. Extra height is advantageous in lower temperatures as it helps retain heat.

It may be necessary to top off the pile with 15 cm of finished compost or bulking agent to provide insulation. This layer protects the surface of the pile from drying, insulates it from heat loss, discourages flies, and filters ammonia and potential odours generated within the pile.

The air supply blower either forces air into the pile or draws air out of it. Forcing air into the pile generates a positive pressure system, while drawing air out of the pile creates negative pressure. The blowers are controlled by a timer or a temperature feedback system similar to a home thermostat. Air circulation in the compost piles provides the needed oxygen for the composting microbes and also prevents excessive heat buildup in the pile. Removing excess heat and water vapour cools the pile to maintain optimum temperatures for microbial activity. A controlled air supply enables construction of large piles, which decreases the need for land.

Blowers used for aeration serve not only to provide oxygen, but also to provide cooling. Blowers can be run continuously or at intervals. When operated at intervals, the blowers are activated either at set time intervals or based on compost temperature. Temperature-set blowers are turned off when the compost cools below a particular temperature. Blower aeration with temperature control allows for greater process control than windrow turning.

In well-designed and operated aerated static pile composting system, odour is much less than the aerobic windrow composting system. Even then odours from the exhaust air could be controlled by filters. The suction method of aeration allows better odour control than positive pressure aeration, particularly if the air is directed through an odour filter. An odour filter is essentially a pile of finished compost that has an affinity for odour causing molecules. The disadvantage of using suction is that not as much air can be pulled through the pile as can be pushed through using positive pressure. Figure 3.16 illustrates composting in an aerated static pile.

Pre-processing involves:

- Segregation
- Size reduction
- Blending with bulking agents

Controlled mechanical aeration enables construction of large piles, thus reducing the demand for land

It is suggested to cover the top of the pile with finished compost or bulking agent to ensure insulation, destruction of pathogens and suppression of odours

**Figure 3.16: Aerated Static Pile<sup>22</sup>**

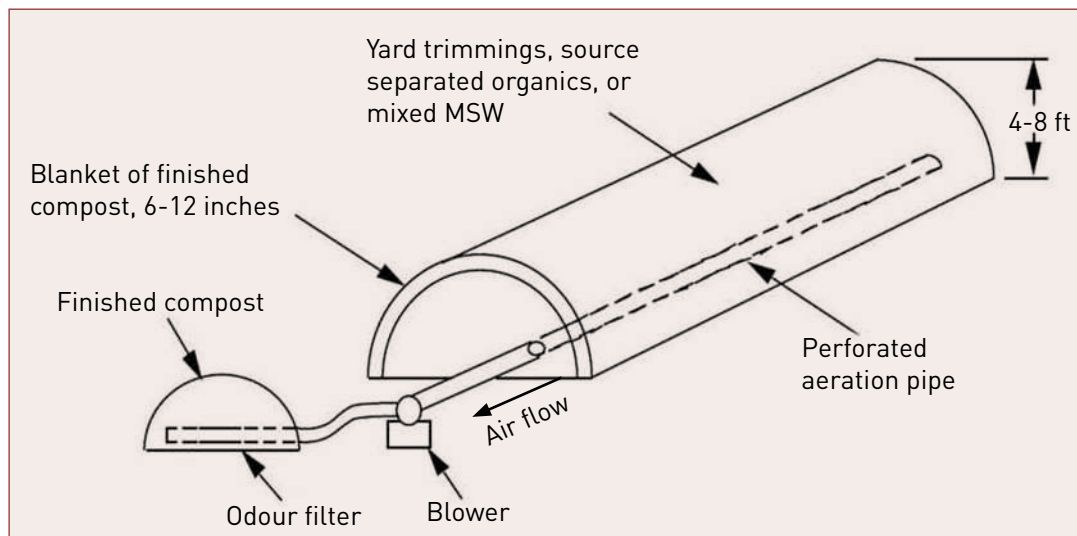

The temperatures in the inner portions of a pile are usually adequate to destroy a significant number of pathogens and weed seeds. The surface of piles, however, may not reach the desired temperatures for destruction of pathogens because piles are not turned in the aerated static pile technology. This problem can be overcome by placing a layer of finished compost 6–12 inches thick over the compost pile.

Producing compost using this technology usually takes 6–12 weeks depending on pre-processing of feedstock, air movement, and temperature control.

**Post processing:** The compost produced needs to undergo post-processing as it is mixed with bulking agents like wood chips. A trommel screen is used to separate the bulking agent from the finished product, which is fine-grained and uniform compost. The size of the compost particles depends on the usage, and the quality should comply with the specifications of FCO, 2009 and 2013 and SWM Rules, 2016.

### 3.2.8.5 IN-VESSEL COMPOSTING

In-vessel composting systems enclose the feedstock in a chamber or vessel that provides adequate mixing, aeration, and moisture. There are several types of in-vessel systems available: drums, silos, digester bins, and tunnels. These vessels can be single or multi-compartment units. In some cases, the vessel rotates; in others, the vessel is stationary and a mixing or agitating mechanism moves the material around. Most in-vessel systems are continuous-feed systems, although some operate in a batch mode. Figure 3.12 below is a depiction of the in-vessel composting process.

<sup>22</sup> Decision Maker's Guide to Solid Waste Management- Vol I, USEPA (1995). Available at: <http://www.epa.gov/osw/nonhaz/municipal/dmg2/chapter7.pdf>.

A top layer of matured compost could also act as an odour filter

Height of pile helps in retaining heat and should be ideally at least 1.5 m to 2.5 m

Aerated static pile technology usually takes 6-12 weeks for producing mature compost

Post processing of compost involves separation of wood chips from the finished products through trommel screen

Composting takes place in single or multi-compartment vessels that provide mixing, aeration and moisture to waste feed





**Figure 3.17: Composting Process in In-Vessel Composting<sup>23</sup>**

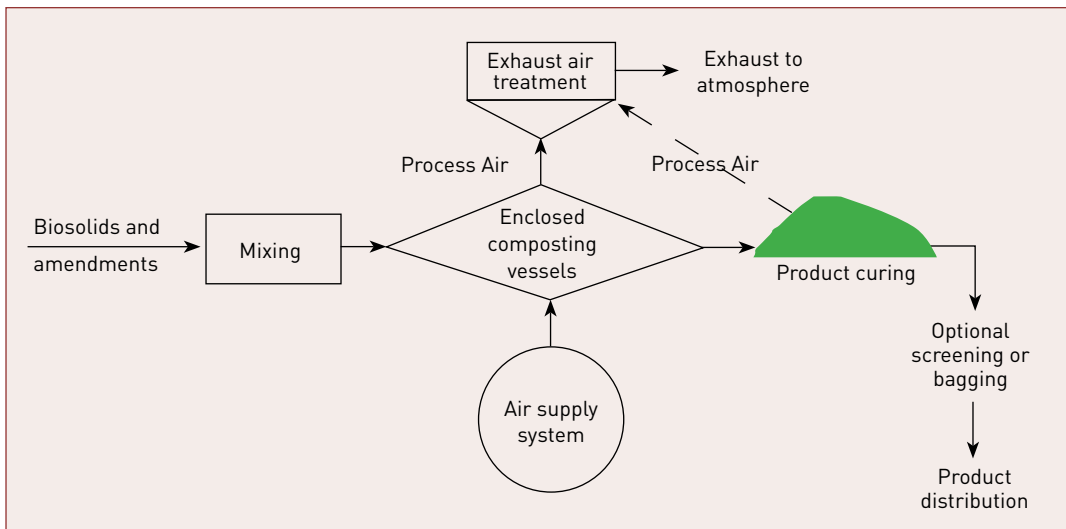

In-Vessel composting is recommended especially for kitchen and canteen food waste

**MSW Feedstock:** The ideal feedstock for in-vessel composting will be organic MSW commingled with food waste, which is highly biodegradable. In fact, in-vessel composting is recommended especially for kitchen and canteen food waste and even slaughterhouse wastes.

**Pre-processing:** In-vessel systems vary in their requirements for pre-processing materials: some require minimal pre-processing (e.g., food waste), while others require extensive pre-processing (mixed waste). All in-vessel systems require further curing after the material has been discharged from the vessel.

**Process:** In-vessel composting is accomplished inside an enclosed container or vessel. Mechanical systems are designed to minimise odour and process time by controlling environmental conditions such as airflow, temperature, and oxygen concentration.

There are several types of in-vessel composting reactors: vertical plug flow, horizontal plug flow, inclined rotary drum type, and agitated bed.

In vertical plug flow systems, the feedstock is introduced into the top of the reactor vessel, and compost is discharged out at the bottom by a horizontally rotating screw auger. Air is introduced in these systems either from the bottom and travels up through the composting mass where it is collected for treatment, or through lances hanging from the top of the reactor.

In horizontal plug flow systems, the compost feedstock and bulking agent mixture are loaded into one end of the reactor. A steel ram pushes the mixture through the reactor. Air is introduced and exhausted

**Types of In-vessel reactors:**

- Vertical plug flow and horizontal plug flow: feedstock is loaded on a periodic basis
- Agitated bin: feedstock is loaded and agitated continuously

23 Biosolids Technology Fact Sheet – In Vessel Composting of Biosolids (2000), USEPA. Available at: [http://water.epa.gov/scitech/wastetech/upload/2002\\_06\\_28\\_mtb\\_invesel.pdf](http://water.epa.gov/scitech/wastetech/upload/2002_06_28_mtb_invesel.pdf).



through slots in the floor of the reactor. Compost is discharged from the end of the reactor opposite the ram.

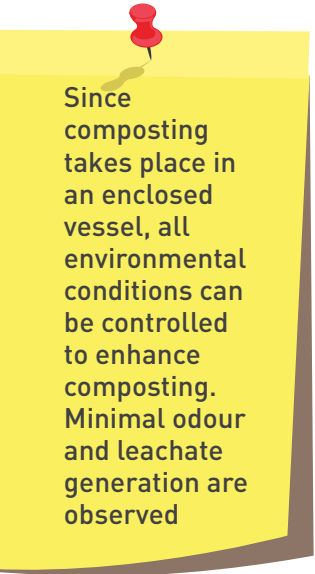

Since composting takes place in an enclosed vessel, all environmental conditions can be controlled to enhance composting. Minimal odour and leachate generation are observed

In the rotary drum type, the composting mass is introduced through a hopper from the higher end. The material gets stabilised fast due to the cascading process and the air flow introduced in the drum. The material goes out in 5–7 days and cured further for 2 weeks followed by screening.

The agitated bed reactors are typically open topped; the feedstock is loaded from above. The composting mass is periodically agitated using a mechanical device, and air is introduced through the floors of the reactors. The vessel is emptied when the feedstock processing is complete.

The detention time in the vessel varies from 3–10 days. Curing period of 2–3 weeks is required after the active composting period. Since in-vessel facilities are highly rated and highly capital-intensive, the design involves a shorter residence period inside the vessel followed by a relatively longer curing period outside the vessel.

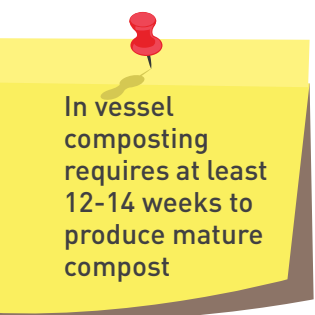

In vessel composting requires at least 12-14 weeks to produce mature compost

A major advantage of in-vessel systems is that all environmental conditions can be carefully controlled to allow rapid composting. These systems, if properly operated, produce minimal odours with little or no leachate. In addition, the air supply can be precisely controlled. Some units are equipped with oxygen sensors, and air is preferentially supplied to the oxygen deficient portion of the vessel. In-vessel systems enable exhaust gases from the vessel to be captured for odour control and treatment.

### 3.2.8.6 DECENTRALISED COMPOSTING

As per SWM Rules, 2016:



#### Clause 15: Duties of local authorities

- (m) collect waste from vegetable, fruit, flower, meat, poultry and fish market on day to day basis and promote setting up of decentralised compost plant or biomethanation plant at suitable locations in the markets or in the vicinity of markets ensuring hygienic conditions;
- (t) involve communities in waste management and promotion of home composting, bio-gas generation, decentralised processing of waste at community level subject to control of odour and maintenance of hygienic conditions around the facility;
- (v) facilitate construction, operation and maintenance of solid waste processing facilities and associated infrastructure on their own or

with private sector participation or through any agency for optimum utilisation of various components of solid waste adopting suitable technology including the following technologies and adhering to the guidelines issued by the Ministry of Urban Development from time to time and standards prescribed by the Central Pollution Control Board. Preference shall be given to decentralised processing to minimize transportation cost and environmental impacts such as-

- a) biomethanation, microbial composting, vermi-composting, anaerobic digestion or any other appropriate processing for bio-stabilisation of biodegradable wastes;

Transportation of MSW through cities is a big issue. Decentralised composting is one of the options to reduce the burden of transportation of MSW in the urban local body (ULB).

Decentralised composting is the composting of source separated organic waste in limited quantities from households, apartments, neighbourhoods, markets, gardens, or the entire ward. The decentralised composting approach reduces transportation costs and makes use of low-cost technologies based mainly on manual labour.

Decentralised composting facilities generally handle waste from very small quantities up to 20 TPD depending on the size of the community and volume of compostable waste material in the waste stream.



Bruhat Bengaluru Mahanagara Palike (BBMP) has clearly specified in its Solid Waste Management Plan that urban local bodies (ULBs) should give directions for installing composting units in every apartment to process wet waste.

**Municipal Solid Waste Feedstock:** The feedstock for decentralised composting should include kitchen waste like food, fruit, and vegetable leftovers (rich in nitrogen content); and yard waste like leaves, twigs, straw, and paper (rich in carbon content).

**Pre-processing:** The waste that reaches the decentralised composting facility should be segregated at source so that only minimal sorting at the facility is required.

**Processing:** Decentralised composting can be practiced using box or bin composting. Box composting is typically carried out at the community level, whereas bin composting may be practiced at individual household level as well.

Colony level and ward level decentralised composting should be promoted by ULBs for source separated organic household waste from very small quantities (upto 20 TPD)

Decentralised composting can be practiced in either box or bin depending on the quantity of waste feed and cost implications

### 3.2.8.6.1 Bin Composting

Depending on the quantum of input material, the size of the bin may be decided. A series of bins may be used to accommodate all incoming waste, as shown in Figure 3.18. The bottom of the bin should be covered with a thick layer (15 cm) of coarse material, such as twigs, broken pieces of stone, or mulch, if available. Over this drainage layer, the feedstock is to be placed in layers. The feedstock should ideally contain a mix of garden or yard waste, kitchen waste, dried leaves, and paper. Water may be sprinkled to keep the heap moist. Care should be taken not to add excess water; the heap should not be wet. Excessively wet conditions can be prevented by placing more dried waste like dried leaves, twigs, and paper. Finished compost may be sprinkled on top to provide the required inoculum and to contain odour. This waste should be turned regularly to hasten the composting process. High temperatures are produced upon turning once every 5–10 days. This also helps to kill larvae and weed seeds, and provides a conducive environment for decomposer organisms. The composting process may take between 45 days and 6 months, depending on the feedstock and turning condition.

Figure 3.18: Bin Composting<sup>24</sup>

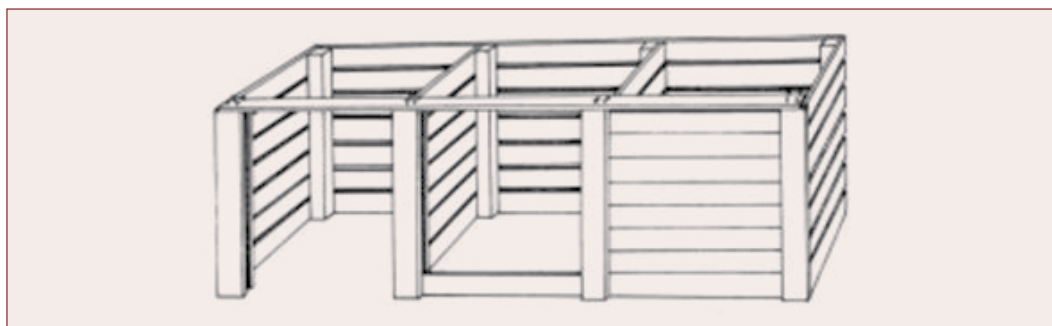

### 3.2.8.6.2 Box Composting

Box composting is practiced at the local community level and can cater to wastes up to 3–5 tonnes. The total space requirements for box are lower than for the windrow technology. The slab on which the boxes are built should be sealed and sloped towards one side. Leachate collection channels should be constructed, leading the leachate away from the boxes toward a central collection point. To improve oxygen supply to the pile within the boxes, the box wall contains gaps between the bricks. The base of the box should be perforated and resistant to corrosion to ensure aeration and drainage of excessive water from the pile. The base should be equipped with small polyvinyl chloride (PVC) pipes or a coated metal grid to facilitate aeration and drainage of excessive water

<sup>24</sup> Composting Methods, Ministry of Agriculture, Food and Fisheries, British Columbia (2004).

from the pile. Perforated PVC pipes placed vertically inside the box provide additional oxygen exchange within the composting material.

Indicative cross sections for a 3-tonne compost box with shed, a composting box, and drainage and aeration for box composting are shown in Figure 3.19, Figure 3.20, and Figure 3.21.

The sorted organic waste is loosely spread in layers of 20 cm into the box, around the vertical aeration pipes. If one box is not sufficient, the remaining waste has to be spread in a second box. Assuming an input load of 3 TPD of organic waste, two boxes are filled within 5–6 days. The boxes receive one layer of waste per day. Every time a layer is added, it is loosely mixed with the previous layer using a fork or shovel. When the box is full, the waste is left for 40 days to go through a thermophilic-mesophilic composting process similar to the windrow system.

Temperature and moisture are frequently monitored. If the material is too dry, water is to be sprayed over the compost and the material is leveled again. Since the waste is thoroughly mixed with coarse material like straw, passive aeration takes place and there is no need to turn the waste. After 40 days, one side of the box is opened and the fresh compost is removed from the box and stored as a pile for further maturation.

Figure 3.19: Cross Section of Typical 3 Tonne Composting Box<sup>25</sup>

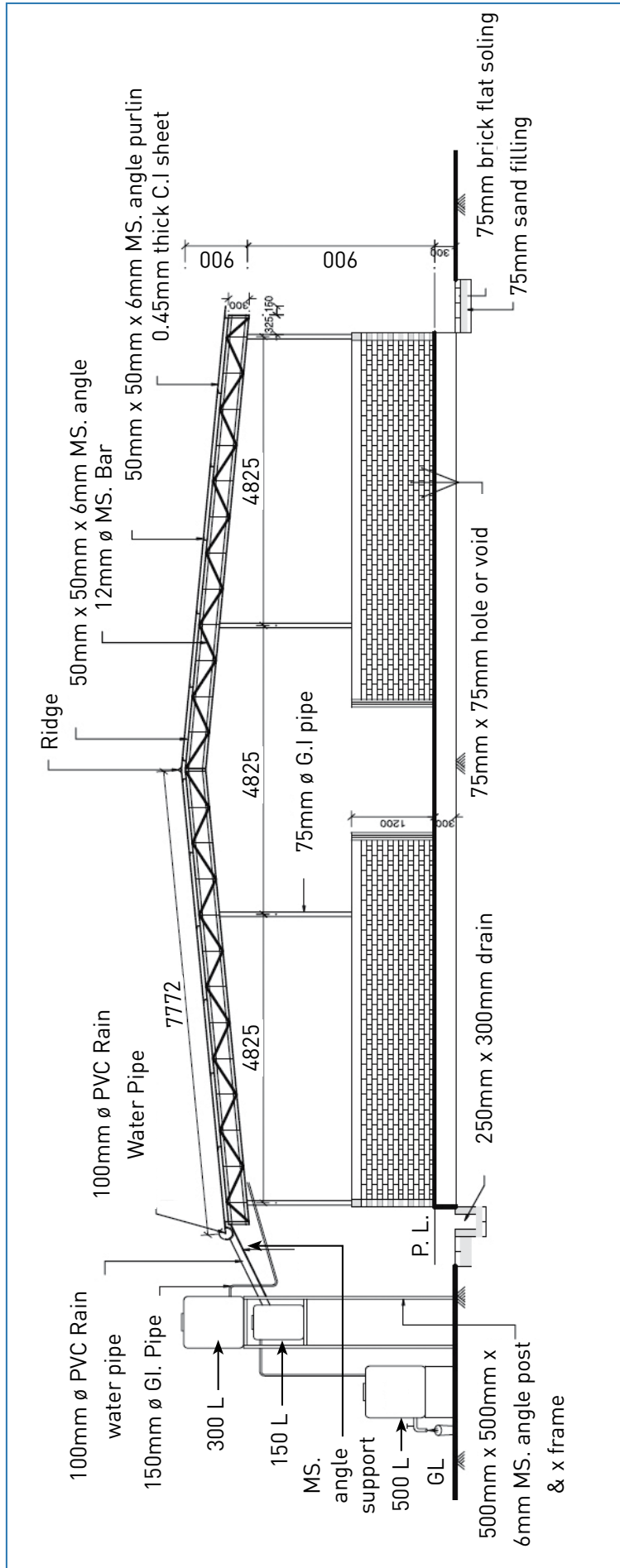

25 Decentralised composting for cities of low and middle income countries - a user's manual; Available at: <http://www.ircwash.org/resources/decentralised-composting-cities-low-and-middle-income-countries-users-manual>



**Figure 3.20: Typical Cross Section of Composting Box<sup>26</sup>**

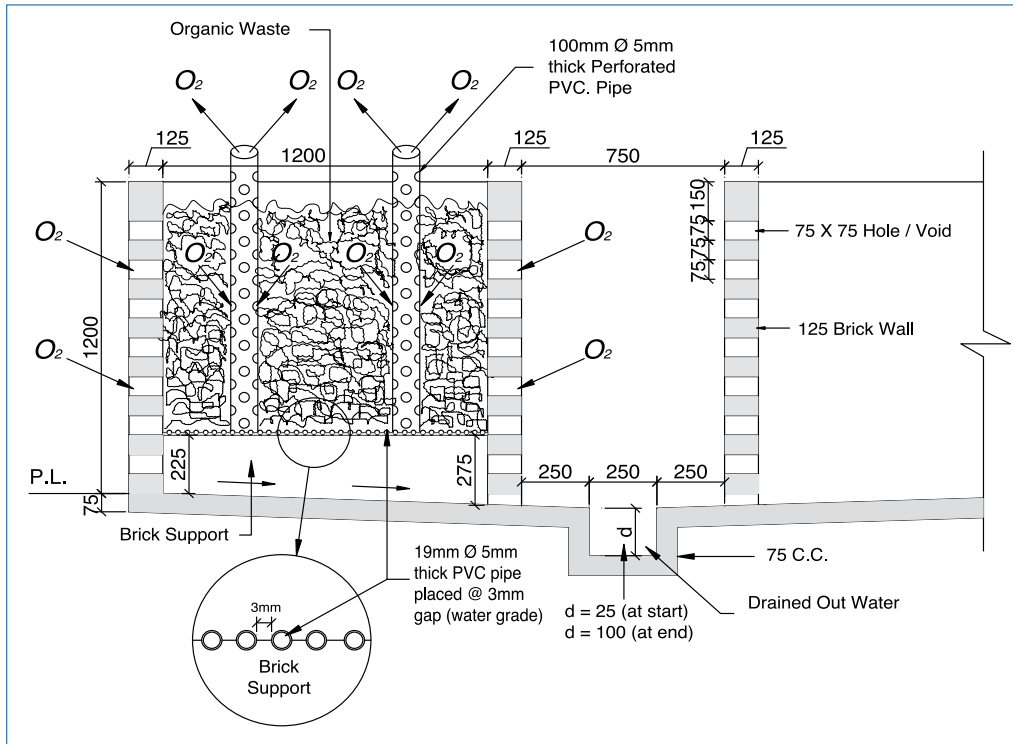

**Figure 3.21: Cross Section of Drainage Channels and Vertical Pipes<sup>27</sup>**

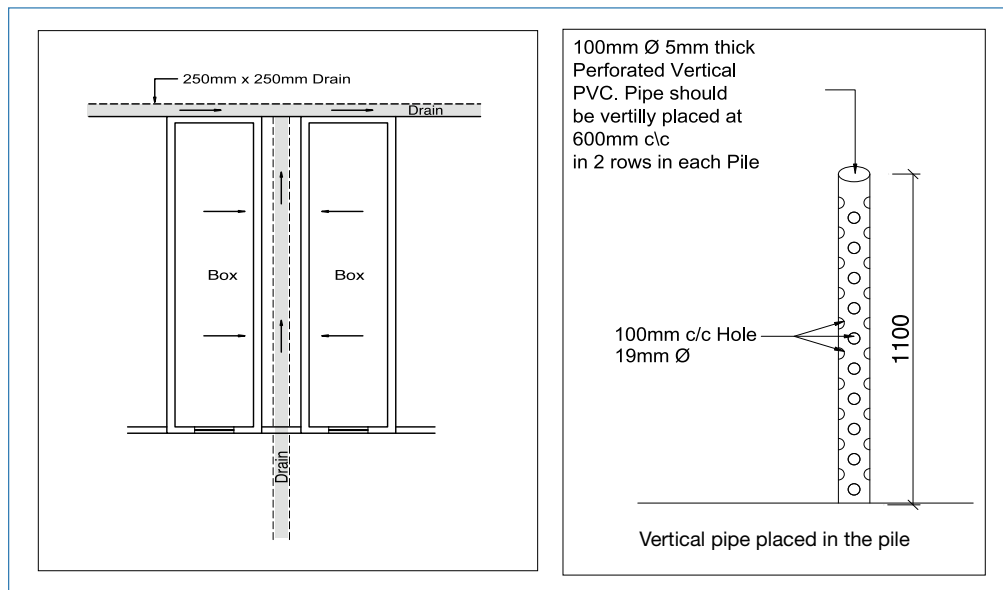

**Screening:** The mature compost has a rather coarse texture. The particle size of the compost strongly depends on the size and composition of input material. Further screening is required to produce finer compost. A flat frame sieve or a rotating drum sieve is used for screening. Each size and type of sieve with its particular mesh size is suited for a particular throughput and application. Selection of screen sizes is dependent on the desired final compost characteristics.

<sup>26</sup> Ibid.

<sup>27</sup> Ibid.



### **Decentralised Composting in a Residential Colony**

At General Pool Residential Accommodation (GPRA) Complex, New Moti Bagh, New Delhi, a novel model of decentralised solid waste management facility has been established with the support from the Ministry of Urban Development and National Buildings Construction Corporation. The decentralised facility receives around 1.5 tonnes of household waste from 1,100 households and 1 tonne of garden and horticultural waste on average. The waste is collected and segregated at the site where wet organics is processed in a shredder prior to its treatment in the organic waste converter (OWC) unit (patented equipment). The shredded organic waste is processed in the OWC for 20–30 minutes and is converted into homogeneous odour-free material. After treatment in OWC, the homogeneous waste is stored in curing trays for 15 days. The trays are equipped with water sprinklers that are automatically timed for sprinkling twice a day. At the end of 15 days cycle, the organics are ready to be used as compost and is used as organic fertilizer for the gardens inside the complex. Garden and horticultural waste is pelletized and sold as biofuel. Plastics from waste are converted into mixture of liquid fuel, which is close to light diesel oil. Other types of recyclables like glass, paper, etc. are sold to recyclers. It is estimated that about 15–20 tonnes of output (compost and pellets) are produced per month yielding about Rs.2,00,000–Rs.2,50,000 lakhs.

This model may be replicated for large gated community with necessary financial support. More information is available at <http://gpwm.strikingly.com/#new-moti-bagh>.



### **Biomechanical Composting Technology for Processing 0.5 to 3.0 Tonnes Per Day of Waste**

A typical batch aerobic digester shreds, cuts, and homogenizes segregated organic waste. The segregated organic waste along with coarse waste such as garden pruning, bones, etc., are shredded in shredding machine prior to feeding into the digester. The organic waste is homogenized with appropriate bio-culture and organic absorbent (e.g., dry leaves, and grasses) media. The process involves mixing and initiation of aerobic digestion of organic waste with inoculants in the machine chamber. Then the material is taken out and stacked in a rack for composting for about 3 weeks, where arrangement for periodic water drip is made. Temperature achieved during the process ensures control of pathogens. Raw compost is formed, having uniform colour and soil with structured coarse material free of bad odour.

The end product is recommended for urban agriculture, terrace gardens, parks, and urban forests.

The batch aerobic digester system requires a three-phase power supply for running the shredder and the aerobic digestion chamber. Periodic maintenance of the machine is essential for continuous operations.

Critical operating factors influencing the performance of a batch aerobic digestion chamber include presence of adequate moisture and absorbent media to ensure sufficient structural space within the material to facilitate continuous aerobic conditions. Temperature and moisture control are critical factors to be monitored continuously.





### **An Institutional Model for Decentralised Waste Management: Miranda House, University of Delhi**

Miranda House, University of Delhi has had a paper recycling plant since 2004. However, an effort of the college towards creating a zero-waste campus was started in 2013 by the initiative of MH Vatavaran, the Environment Society, with encouragement and active support from the Principal. Under this initiative, the college has set up a composting unit in addition to the paper recycling unit. The handmade paper unit is managed by operating staff specially employed by the college, while the operation of the composting unit has been contracted out to GreenBandhu—the firm which installed the plant—for 1 year.

The composting facility manages about 150 kg of organic waste on a daily basis including waste from the hostel kitchen and canteen, as well as horticultural waste. The segregated kitchen waste that is received at the plant sometimes needs further segregation. This segregated waste is pulverized and dewatered, mixed with horticulture waste and cured compost, and put in covered containers for composting. The final product is utilized for the college garden, and the surplus manure is bought by the service provider at the rate of Rs. 5 per kg.

The handmade paper unit consisting of a shredder, beater, univat, screw press, and calendering machine handles the paper waste from the college. On average, approximately 12–15 sheets are produced per day. Initially, file folders, gift envelopes, and carry bags were being produced. The college is now experimenting with producing printing quality handmade paper for internal use.

The overall cost for the installation of the composting facility was Rs. 4,00,000, and the college pays Rs. 5,000 and Rs. 1,200 per month to the service provider as salary for an operator and a helper respectively. Approximately 50 kg of compost is produced on average every day. The cost for installation of the currently functional handmade paper unit is approximately Rs. 4,50,000.

Section 1.4.5.8 of Part II contain case studies of successful decentralised SWM initiatives.

### **3.2.8.7 VERMICOMPOSTING**



As per SWM Rules, 2016:

**Clause 15: Duties and responsibilities of local authorities:-**

- (t) involve communities in waste management and promotion of home composting, bio-gas generation, decentralised processing of waste at community level subject to control of odour and maintenance of hygienic conditions around the facility;
- (v) facilitate construction, operation and maintenance of solid waste processing facilities and associated infrastructure on their own or

with private sector participation or through any agency for optimum utilisation of various components of solid waste adopting suitable technology including the following technologies and adhering to the guidelines issued by the Ministry of Urban Development from time to time and standards prescribed by the Central Pollution Control Board. Preference shall be given to decentralised processing to minimize transportation cost and environmental impacts such as-

- a) biomethanation, microbial composting, vermi-composting, anaerobic digestion or any other appropriate processing for biostabilisation of biodegradable wastes;

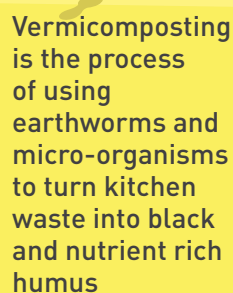

Vermicomposting is the process of using earthworms and micro-organisms to turn kitchen waste into black and nutrient rich humus

Vermicompost is the castings of earthworms. In the present context, vermicomposting is the process of composting the biodegradable fraction of MSW with the help of earthworms, resulting in the production of vermicompost which can be used in agricultural fields as a soil conditioner and nutrient supplier. Vermicompost is richer in plant nutrients compared with normal compost prepared from similar material; it has some cocoons which develop into worms when put in the soil and continues to do their work of conversion. Vermicompost draws better market price as compared with compost and, in addition, sale of worms can bring in additional revenue. The worms can be further utilised for initiating a fresh vermicomposting process and also as bait for fishing. The efficiency of vermicomposting process depends on selection of proper species of earthworms and their optimal growth.

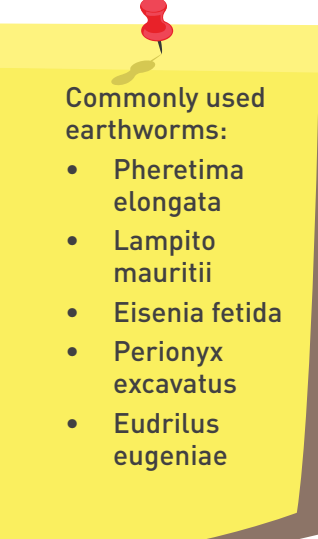

Commonly used earthworms:

- *Pheretima elongata*
- *Lampito mauritii*
- *Eisenia fetida*
- *Perionyx excavatus*
- *Eudrilus eugeniae*

Vermicomposting is typically suited for managing smaller waste quantities. It is an ideal technology for towns that generate up to 50 TPD of MSW which is thoroughly segregated either at source or in the plant. The worm species that are considered efficient for conversion of waste are *Eisenia fetida*, *Perionyx excavatus*, *Lampito mauritii*, *Eudrilus eugeniae*, *Lumbricus rubellus*, *Pheretima elongata*, etc.

**Municipal Solid Waste Feedstock:** Kitchen waste is the preferred feedstock for vermicomposting; however, some materials like meat waste, greasy and oily food, and dairy products tend to foul the bed and cause bad odour. Other suitable feedstock are vegetable market waste, garden waste, cow dung, and agricultural waste. In fact, stabilised cattle manure is very useful in preparing the bed and initiating the vermicomposting process.

**Vermi bed or pit:** A vermicompost pit of any convenient dimension can be constructed in the backyard or garden, field, or shed. It may be a single pit, two or four interconnected pits, or preferably above ground chambers with proper water outlets. However, the depth or height should not be more than 0.75 m so that the bottom part also gets some aeration and the earthworms are not put under a heavy moist load. Two

important points to keep in consideration while vermicomposting are the protection of the worms from predators (ants, birds, snakes, etc.) and maintenance of high temperature (above 40°C) and dry environment (low moisture below 40%). Temperature of 20°C–30°C and moisture of about 70% is ideal for most of the earthworm species employed for vermicomposting. This means that the climatic conditions should be conducive unless the whole process is carried out in a carefully controlled climate. Carbon-to-nitrogen (C/N) ratio of 15–35: 1 is suitable. Typical density of earthworms should be 1–4 kg per m<sup>2</sup> on average.



Vermicomposting takes place at 20–30°C which is the most favourable temperature for ensuring survival of earthworms

The vermin bed is a multilayered chamber lined with coarse sand or gunny bags, or straw and stalks at the bottom, above which a 15–20 cm layer of lightly moist composted cattle manure is placed. Some operators prefer to mix loamy soil with the composted manure. Suitable number of earthworms are introduced in this layer. After 1–2 days, segregated biodegradable waste is introduced. In small operations, the waste can be directly put over the cattle manure in thin layers. The worms move up to reach the waste material which is their food. The bed is covered loosely with wet gunny bags or palm fronds or any available material, serving two purposes: (i) moisture is retained, and (ii) darkness is maintained as the worms usually want to stay away from light. One has to take care that any material containing toxic matter or heavy metals does not get into the vermin bed.

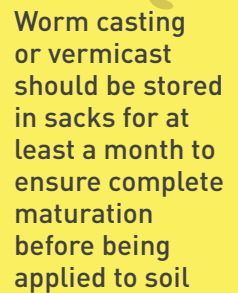

Worm casting or vermicast should be stored in sacks for at least a month to ensure complete maturation before being applied to soil

For large operations, it is necessary to pre-compost the input material so that the heat generated during the initial phase gets dissipated and the material cools down to ambient conditions. Pre-composting is best done in aerobic windrows or aerated static piles for faster results. Building up a large workforce of worms is essential for processing large quantity of waste.

Under Indian conditions, the entire cycle of vermicomposting takes about 10 weeks. In case of pre-composted material, about 7–8 weeks is required. For harvesting, great care is required to ensure that the worms are not injured. Coning of the vermicompost is done when the worms move downwards to the bottom. The vermicompost is carefully scooped out from the top. As the pit progressively gets emptied, the last 15–20 cm layer which retains the worms is used for next load of waste to be treated. Commonly encountered problems, as well as possible causes and solutions are tabulated below in Table 3.4

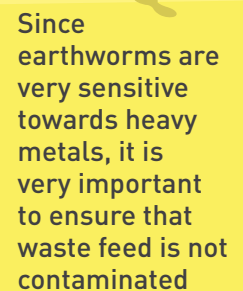

Since earthworms are very sensitive towards heavy metals, it is very important to ensure that waste feed is not contaminated

**Table 3.4: Vermicomposting- Problems, Possible Causes and Solutions<sup>28</sup>**

| PROBLEMS                         | POSSIBLE CAUSES                                     | SOLUTIONS   |
|----------------------------------|---|---|
| Foul odour                       | Overfeeding   | Remove the excess food, remove meat or dairy products if any                      |
|                                  | Not enough air circulation or anaerobic conditions  | Fluff up or loosen bedding  |
|                                  | Bed too wet   | Add bedding to absorb moisture  |
| Flies                            | Waste exposed                                       | Bury the waste completely   |
| Ant infestation                  |   | Immerse the base or feet of the vermi bed in water                                |
|                                  |   | A barrier of chalk or petroleum jelly may repel the ants                          |
|                                  |   | If bedding seems dry, add water   |
| Mite infestation                 |   | Avoid adding foods with high moisture content                                     |
| Worms are dying or crawling away | Bed too wet   | Do not water till it reaches appropriate moisture                                 |
|                                  | Bed too dry   | Sprinkle water till it turns moist  |
|                                  | Excess temperature, not enough air, not enough food | Sprinkle water till it turns moist and temperature drops, add waste appropriately |
|                                  | Bed packed tightly                                  | Turn bed and make it fluffy   |

### 3.2.9 YARD WASTE COMPOSTING



As per SWM Rules, 2016:

**Clause 15: Duties and responsibilities of local authorities:-**

(p) collect horticulture, parks and garden waste separately and process in the parks and gardens, as far as possible.

ULBs should ensure that horticulture waste in parks and gardens should be used in the most optimum ways to minimise the cost of collection and transportation of such waste. Yard waste such as leaves, grass clippings, straw, and nonwoody plant trimmings can be composted on site, thereby reducing the amount of waste to be handled by ULBs. However, some of these contain higher percentage of lignocellulosic material which takes much longer time for composting process to complete, e.g., straw, dried stems, etc. These can be readily converted into mulch in shorter time.

In places where large quantities of horticultural waste are generated, e.g., leaves and pruning, especially during rainy, autumn, and spring seasons, it may be a good idea to convert such leftover material into mulch which could not be composted.

<sup>28</sup> IEC brochure for Vermicomposting, GIZ (2012).

**Feedstock:** Leaves, grass clippings, and weeds make good compost. Additionally, fruit and vegetable scraps can also be composted. Woody brown materials such as autumn leaves are high in carbon while green, moist material such as grass clippings are high in nitrogen.

- high nitrogen ‘green’ ingredients include grass clippings, weeds, fruit and vegetables, coffee grounds, tea bags, eggshells, manure, alfalfa hay or meal.
- high carbon ‘brown’ ingredients include autumn leaves, straw, cornstalks, wood chips, saw dust, pine needles.

Using approximately three parts of ‘brown’ material to one part ‘green’ material optimises the composting process and prevents odours from developing.

**Process:** Barrel or drum composter can be used for composting to save space and hasten decomposition. Bins made of wire, wood, or even garbage cans with drainage holes can be used for the purpose. It should be ensured that the bins are rodent resistant and have a secure cover. The bottom of the pile should consist of coarse material like corn stalks to build in air passages. Alternating layers of ‘brown’ and ‘green’ material with shovel full of compost or farmyard manure on top of each layer should be added. Shredding of leaves and twigs will shorten the composting time. A nitrogen source like manure should be placed on top of this layer to increase microbial activity and hasten the process. Water should be added to the pile to keep it moist; however, care should be taken to prevent waterlogging. The pile should be turned every few days to provide aeration and prevent odours. A properly mixed and adequately turned compost pile does not produce odour.

If only leaves are to be composted, layering is not required. Fallen leaves can be added as they are collected and should be moistened. However, addition of manure will be required to hasten decomposition.

Generally, the compost from a well-managed pile made up of shredded material under warm conditions will be ready in about 2 months. When the compost is ready, the pile will be reduced to half of its original size and will have an earthy smell to it. Table 3.5 lists some of the common problems encountered during yard waste composting and their solutions.

**Table 3.5: Yard Composting-Problems and Solutions<sup>29</sup>**

| <b>PROBLEMS</b>  | <b>POSSIBLE CAUSES</b>   | <b>SOLUTION</b>  |
|--|--|--|
| Material in the bin not decomposing or not heating up at all | <ul style="list-style-type: none"> <li>• Not enough nitrogen</li> <li>• Not enough oxygen</li> <li>• Not enough moisture</li> </ul>  | <ul style="list-style-type: none"> <li>• Add enough nitrogen-rich sources like manure, grass clippings, or food scraps</li> <li>• Mix the material regularly</li> <li>• Add water to moist the pile</li> </ul>   |
| Matted leaves or grass clippings are not decomposing         | <ul style="list-style-type: none"> <li>• Poor aeration due to self compaction, especially when wet</li> <li>• Lack of moisture</li> </ul>                                      | <ul style="list-style-type: none"> <li>• Loosen material with rake</li> <li>• Avoid adding thick layers of same material.</li> <li>• Shred material before mixing</li> </ul>   |
| Stinks like rancid butter, vinegar, or rotten eggs           | <ul style="list-style-type: none"> <li>• Lack of oxygen</li> <li>• Bin is too wet or compacted</li> <li>• Presence of cooked food</li> </ul>                                   | <ul style="list-style-type: none"> <li>• Turn the material to provide aeration</li> <li>• Add coarse dry material like straw, hay, or leaves to soak excess moisture and mix well</li> </ul>   |
| Vermin problem or fly larvae                                 | <ul style="list-style-type: none"> <li>• Inappropriate material (meat, dairy products)</li> <li>• Bin is too wet</li> <li>• Poor aeration</li> </ul>                           | <ul style="list-style-type: none"> <li>• Adjust the moisture by adding dry material or ash.</li> <li>• Place the bin where there is sun so that heat can destroy fly larvae, weed seeds, and other pathogens.</li> <li>• Change to fly-proof closed bin with enough aeration.</li> </ul> |
| Odour like ammonia   | <ul style="list-style-type: none"> <li>• Not enough carbon</li> </ul>  | <ul style="list-style-type: none"> <li>• Add brown material like dried leaves, straw, hay, shredded paper, etc.</li> </ul>   |
| Attracts rodents, flies, or other animals                    | <ul style="list-style-type: none"> <li>• Inappropriate material (meat, oil, bones)</li> <li>• Material like fresh food scrap is too close to the surface of the bin</li> </ul> | <ul style="list-style-type: none"> <li>• Remove inappropriate materials from compost bin.</li> <li>• Switch to a rodent-proof safe bin.</li> </ul>   |

<sup>29</sup> Practical Action, "Home Composting Bins". Available at: <http://practicalaction.org/media/preview/12742/lng:en>.



### 3.2.10 SUMMARY: CRITERIA FOR SELECTION OF COMPOSTING TECHNOLOGIES

The choice of composting technology depends on a number of criteria which include quantity of waste to be processed, land requirement, climatic conditions, stability, energy requirements, financial implications, monitoring requirements, and aesthetic issues. Table 3.6 gives a brief overview of different composting technologies.

**Table 3.6: Summary of Different Composting Technologies<sup>30</sup>**

| PARAMETERS                                  | WINDROW                                       | AERATED STATIC PILE   | IN-VESSEL   | VERMICOMPOSTING   |
|---|---|---|---|---|
| General                                     | Simple technology for large scale application | Effective for farm and municipal use  | Large-scale systems for commercial applications           | Small scale   |
| Amount of input waste per day to be treated | 1–500 tonnes                                  | 1–500 tonnes  | 1–300 tonnes  | upto 50 tonnes  |
| Land requirement                            | 8 ha for 500 TPD including buffer zones       | 5 ha for 500 TPD (Less land required given faster rates and effective pile volumes) | 4 ha for 500 TPD (Limited land due to rapid rates)        | 2 ha for 50 TPD   |
| Time  | 8 weeks                                       | 5 weeks   | 4 weeks (3–5 days in vessel; 3 weeks to mature)           | 8 -10 weeks   |
| Ambient temperature                         | Not temperature sensitive                     | Not temperature sensitive   | Not temperature sensitive                                 | Temperature sensitive (20°C–40°C ideal range, maximum 40°C)                               |
| Energy input                                | Moderate                                      | Moderate (2–3 hours aeration)   | High  | Low   |
| Financial implications                      | Moderate                                      | Costly  | Very costly   | Moderate but purchase of exotic earthworms suitable for MSW vermicomposting are expensive |
| Odour and aesthetic issues                  | Odour is an issue if turning is inadequate    | Moderate but controls can be used such as pile insulation and filters on air system | Minimum due to equipment failure or system design failure | None  |

30 Expert Committee for the revision of MSWM Manual (2014).

### 3.2.11 MONITORING OF COMPOST PLANTS

Routine testing and monitoring is an essential part of any composting operation. Monitoring the composting process provides information necessary to maintain a high-quality operation. At least the following parameters should be monitored:

- windrow temperature (daily);
- oxygen concentrations in the compost mass (daily);
- moisture content (daily); and
- full analysis as per FCO, 2009 and 2013 for each batch after preparation of finished compost.

Compost quality should be monitored by the operator of the compost facility per batch of compost being sold to the market. If the facility does not have sufficient laboratory capacity to perform all the tests, National Accreditation Board for Testing and Calibration Laboratories (NABL) accredited laboratories should be contracted to perform these tests on a regular basis. Compost that does not meet specified standards should be put to uses other than for application to food crops. A standard operating procedure for windrow composting is given in Annexure 5.



Compost should meet standards set by FCO, 2009 and its amendments before being used as soil conditioner



Standards for PROM are included in the FCO, 2013

#### 3.2.11.1 QUALITY PARAMETERS FOR COMPOST PRODUCTION

The compost which is to be used as fertiliser for food crops should abide by the more stringent FCO, 2009, while compost used as a soil conditioner and for other purposes should at least meet the requirements of SWM Rules, 2016. Phosphatic fertiliser is in short supply in the country. The use of phosphate rich organic manure (PROM) can reduce the use of phosphatic fertilisers to some extent; PROM is formed by the mixing of rock phosphate with MSW derived compost. The FCO, 2013 specified quality standards for PROM, while retaining the standards specified in FCO, 2009 for organic compost.



As per SWM Rules, 2016, Table 3.7 specifies the compost quality standards. Table 3.8 presents the standards for vermicompost quality as specified by the FCO, 2009.



*i*

Prevention of cross contamination of organic material with inerts and street sweeping coupled with appropriate pre-sorting and segregation of raw material for composting will, to a large extent, ensure that heavy metal contamination is minimised in the finished compost.



**Table 3.7: Compost Quality Standards as per Solid Waste Management Rules, 2016; Fertiliser Control Order, 2009; and Fertiliser Control Order, 2013**

| PARAMETERS   | ORGANIC COMPOST  | PHOSPHATE RICH ORGANIC MANURE (PROM)                     |
|--|--|--|
|  | FCO 2009   | FCO (PROM) 2013  |
| Arsenic (mg/kg)  | 10.00  | 10.00  |
| Cadmium (mg/kg)  | 5.00   | 5.00   |
| Chromium (mg/kg)   | 50.00  | 50.00  |
| Copper (mg/kg)   | 300.00   | 300.00   |
| Lead (mg/kg)   | 100.00   | 100.00   |
| Mercury (mg/kg)  | 0.15   | 0.15   |
| Nickel (mg/kg)   | 50.00  | 50.00  |
| Zinc (mg/kg)   | 1000.00  | 1000.00  |
| C/N ratio  | <20  | less than 20:1   |
| pH   | 6.5 - 7.5  | (1:5 solution) maximum<br>6.7                            |
| Moisture, % by weight, maximum   | 15.0-25.0  | 25.0   |
| Bulk density (g/cm <sup>3</sup> )  | <1.0   | Less than 1.6  |
| Total organic carbon, % by weight, minimum   | 12.0   | 7.9  |
| Total nitrogen (N), % by weight, minimum   | 0.8  | 0.4  |
| Total phosphate (P <sub>2</sub> O <sub>5</sub> ), % by weight, minimum   | 0.4  | 10.4   |
| Total potassium (K <sub>2</sub> O), % by weight, minimum   | 0.4  | —  |
| Colour   | Dark brown to black                                      | —  |
| Odour  | Absence of foul odour                                    | —  |
| Particle size  | Minimum 90% material should pass through 4.0 mm IS sieve | Minimum 90% material should pass through 4.0 mm IS sieve |
| Conductivity (as dsm <sup>-1</sup> ), not more than  | 4.0  | 8.2  |
| <p>Note:</p> <ul style="list-style-type: none"> <li>• Tolerance limits as per FCO: <ul style="list-style-type: none"> <li>i. For compost- A sum total of nitrogen, phosphorus and potassium nutrients shall not be less than 1.5% in compost</li> <li>ii. For PROM- No such directive</li> </ul> </li> <li>• “—” Not applicable</li> </ul> |  |  |

**Table 3.8: Vermicompost Standards as per Fertilizer Control Order, 2009**

| S.NO   | CRITERIA  | VALUE  |
|--|---|--|
| 1.   | Moisture % by weight  | 15.0–25.0  |
| 2.   | Colour  | Dark brown to black                                      |
| 3.   | Odour   | Absence of foul odour                                    |
| 4.   | Particle size   | Minimum 90% material should pass through 4.0 mm IS sieve |
| 5.   | Bulk density  | 0.7–0.9  |
| 6.   | Total organic carbon, % by weight, minimum                              | 18.0   |
| 7.   | Total nitrogen (N), % by weight, minimum                                | 1.0  |
| 8.   | Total phosphates (P <sub>2</sub> O <sub>5</sub> ), % by weight, minimum | 0.8  |
| 9.   | Total potash (K <sub>2</sub> O), % by weight, minimum                   | 0.8  |
| 10.  | Heavy metal content (mg/kg) by weight, maximum                          |  |
|  | a. Cadmium (Cd)   | 5.00   |
|  | b. Chromium (Cr)  | 50.0   |
|  | c. Nickel (Ni)  | 50.0   |
|  | d. Lead (Pb)  | 100.0  |
| <p>Note:</p> <p>Tolerance Limit for vermicompost: The sum total of Nitrogen, Phosphorus and Potassium nutrients should not be less than 2.5 % in the case of vermicompost.</p> |   |  |

### 3.2.12 INTEGRATION OF THE INFORMAL SECTOR

Integrating waste pickers into organised or formal waste management programmes can improve the quality of their working conditions and their earning. Waste pickers could be trained and employed in the pre-processing facility at the compost plant. Since they are already used to work with waste material, they have good acumen and aptitude for such work. Refer to Section 3.1.6 and Section 1.4.5.9 of Part II for further details on integrating the waste pickers into formal systems.

### 3.2.13 HUMAN RESOURCE REQUIREMENT

Compost plant operators shall ensure that all personnel assigned to the operation shall be trained in subjects pertinent to operation and maintenance (O&M), physical contaminants, and hazardous material recognition and screening, with emphasis on odour impact management and emergency procedures. A record of such training shall be maintained on the site.

The level and nature of staffing and training should be adequate for environmentally responsible and safe management of the composting facility. Staffing levels should be high enough to ensure that the facility can comply at all times with provisions of the SWM Rules, 2016 and other applicable guidance or consent.

Composting plants can provide livelihood opportunities to the informal sector

Training and capacity building of all staff in waste management plants is essential

Staff training should be effective enough to ensure the following:

- all operators of the plant and its equipment are skilled at undertaking all the tasks required of them;
- all personnel who inspect incoming waste are skilled at identifying unacceptable waste and recording data accurately;
- laboratory staff is well informed of sampling practices and requisite analysis. They should be conversant with the impacts of different parameters to be able to suggest process modifications based on an analysis of the results. Constant communication with plant operating staff on related matters is crucial;
- compost quality should be regularly checked through NABL accredited laboratories, at least once a month or as per direction of the State Pollution Control Board (SPCB).

Staffing requirements will vary as a function of the size of the facility, the type of waste input, and the diversity and complexity of site operations.

Indicative staff requirement for a 300 TPD windrow composting plant is given in Table 3.9:

**Table 3.9: Indicative Staff Requirement for a 300 TPD Compost Plant (Windrow)<sup>31</sup>**

| S. NO. | GRADE                | QUALIFICATION                       | EXPERIENCE   | NUMBER |
|--------|----------------------|-------------------------------------|--------------|--------|
| 1.     | General manager      | Bachelor of Engineering (BE)        | 2-3 years    | 1      |
| 2.     | Shift in-charge      | Diploma                             | 1 to 2 years | 2      |
| 3.     | Mechanic             | Industrial Training Institute (ITI) | 3 years      | 2      |
| 4.     | Plant operator       | Higher Secondary School             | 1-2 years    | 3      |
| 5.     | Chemist              | Bachelor of Science                 | 3 years      | 2      |
| 6.     | Accounts officer     | Bachelor of Commerce                | 3 years      | 1      |
| 7.     | Skilled worker       | -                                   | 2-3 years    | 4      |
| 8.     | Semi-skilled workers | -                                   | -            | 6      |
| 9.     | Unskilled worker     | -                                   | -            | 12     |
| 10.    | Drivers              | -                                   | 3-4 years    | 20     |
| 11.    | Contractual labour   | -                                   | -            | 24     |

### 3.2.14 GREENHOUSE GAS EMISSION AVOIDANCE THROUGH COMPOSTING

MSW contains large fractions of organic waste, which is a potential source of methane and other greenhouse gas (GHG) emissions. Methane is a highly polluting GHG with a global warming potential 21 times more than that of carbon dioxide. Composting, an aerobic process, transforms a

<sup>31</sup> Inter-Ministerial Task Force on Integrated Plant Nutrient Management Using City Compost (2005).

range of organic substrates into stable humus like material through microbial decomposition. In the process, methane emissions to the atmosphere are avoided, which would otherwise result from anaerobic decay of waste in a disposal site, e.g., open waste disposal site or landfills.

Composting is acknowledged by the United Nations Framework Convention on Climate Change (UNFCCC) as one of the emission reduction methodologies in waste management. However, the potential for realising financial gain through sale of carbon credits is rather limited in the current global climate regime.

### 3.3 WASTE TO ENERGY

Waste to energy (WtE) refers to the process of generating energy in the form of heat or electricity from MSW. Energy from MSW can be achieved through:

1. thermal processes like incineration or combustion of refuse derived fuel (RDF); and
2. biological processes like biomethanation and further conversion into electrical power or automotive fuel (compressed biogas).

#### 3.3.1 SOLID WASTE MANAGEMENT RULES, 2016: GUIDANCE ON WASTE TO ENERGY



As per SWM Rules, 2016:

Clause 15: Duties and responsibilities of local authorities:-

- (v) facilitate construction, operation and maintenance of solid waste processing facilities and associated infrastructure on their own or with private sector participation or through any agency for optimum utilisation of various components of solid waste adopting suitable technology including the following technologies and adhering to the guidelines issued by the Ministry of Urban Development from time to time and standards prescribed by the Central Pollution Control Board. Preference shall be given to decentralised processing to minimize transportation cost and environmental impacts such as-
  - b) waste to energy processes including refused derived fuel for combustible fraction of waste or supply as feedstock to solid waste based power plants or cement kilns;

Clause 18: Duties of the industrial units located within one hundred km from the refused derived fuel and waste to energy plants based on solid waste- All industrial units using fuel and located within one hundred km from a solid waste based refused derived fuel plant shall make arrangements within six months from the date of notification of these rules to replace at least five percent of their fuel requirement by refused derived fuel so produced.

It is assumed that at least 65 to 80% of energy content of waste can be recovered as heat energy through waste to energy technologies



### Clause 21. Criteria for waste to energy process.-

- (1) Non recyclable waste having calorific value of 1500 K/cal/kg or more shall not be disposed of on landfills and shall only be utilised for generating energy either or through refuse derived fuel or by giving away as feed stock for preparing refuse derived fuel.
- (2) High calorific wastes shall be used for co-processing in cement or thermal power plants.
- (3) The local body or an operator of facility or an agency designated by them proposing to set up waste to energy plant of more than five tones per day processing capacity shall submit an application in Form-I to the State Pollution Control Board or Pollution Control Committee, as the case may be, for authorisation.
- (4) The State Pollution Control Board or Pollution Control Committee, on receiving such application for setting up waste to energy facility, shall examine the same and grant permission within sixty days.

### 3.3.2 WASTE TO ENERGY (WtE) IN THE INTEGRATED SOLID WASTE MANAGEMENT HIERARCHY

The integrated solid waste management (ISWM) hierarchy indicates that recovery of energy from waste is preferable only after considering the potential for recovery of material. Valuable energy is sought to be recovered after ensuring that all possible reduce, recycle, and recover mechanisms have been adopted.

Figure 3.22: WtE in the Integrated Solid Waste Management Hierarchy

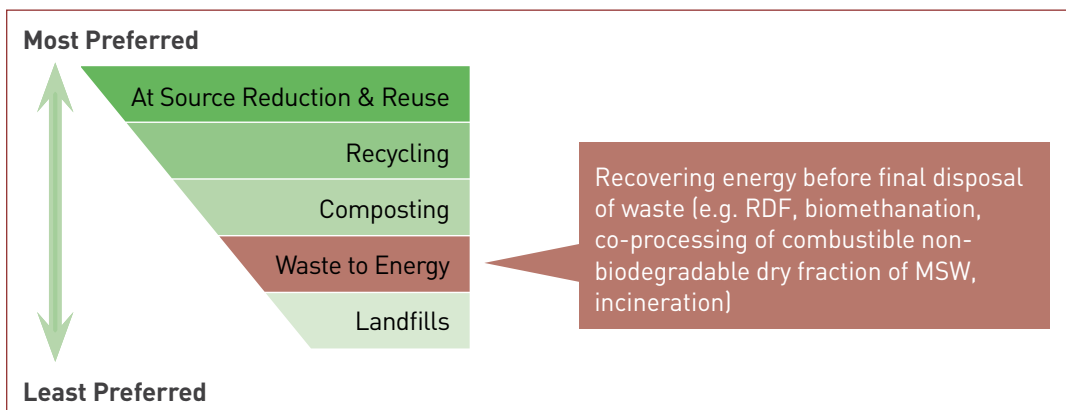

Proven WtE technologies include incineration of MSW with recovery of energy, either as heat or converted to electricity and production of high calorific value RDF, which is fast gaining acceptance. However, stringent norms specifying quality standards and conditions for its utilisation are awaited from the Ministry of Environment, Forest and Climate Change (MoEFCC). There are various other technologies under discussion, such as pyrolysis and gasification, which are not yet proven under Indian conditions for treatment of MSW.

Since recovering energy value in waste prior to final disposal is considered preferable to direct landfilling, WtE option lies above landfilling in ISWM hierarchy

Combustion technologies in India have to cope with the comparably high moisture and inert content, as is common in Indian waste. However, doorstep segregation of waste, segregated management of inert wastes, and pre-treatment to separate the high calorific fraction (RDF) can enable efficient thermal processes (refer to Section 3.5 of Part II).

Application of technologies like pyrolysis and gasification to treat MSW is at a very nascent stage in the country, with one or two experimental plants in the process of being set up. Nevertheless, Section 3.6 of Part II provides an overview of these technologies.

WTE plants are an expensive option for managing MSW, requiring skilled staffing and adoption of high-level technologies. They also have the potential to cause significant environmental impacts through emissions and fly ashes if plants are not operated efficiently and if appropriate emission control mechanisms are not adopted.



#### **Guidelines by the Task Force Constituted By Planning Commission on Waste to Energy (WtE)**

It is essential to explore ways and means to promote integrated waste processing optimally to manage the ever growing waste quantities. The draft guidelines by the Task Force constituted by the Planning Commission (2014) for establishing Waste to Energy plants include the following:

- The appropriateness of WtE for a community must be evaluated on a case-by-case basis and should only be considered after waste reduction and responsible recycling programs are implemented
- Minimum eligibility criteria for getting financial support to set up WtE plants are the following:
  - Municipal authority must select a suitable concessionaire through a competitive bidding to set up, operate and maintain the waste processing facility for a long term not below 20 years;
  - The applicant must be a developer or technology provider who will actually construct, operate and maintain the plant;
  - The developer must have critical staffing on board on full time basis or on long term contract;
  - The developer must have past experience of operation and maintenance (O&M) of at least one such plant.

Incineration of municipal solid waste (along with energy recovery) can reduce the volume of waste to be landfilled by 90%

### **3.3.3 INCINERATION**

Incineration is a waste treatment process that involves combustion of waste at very high temperatures in the presence of oxygen and results in the production of ash, flue gas, and heat. Incineration is a feasible technology for combustion of unprocessed or minimum processed refuse and for the segregated fraction of high calorific value waste.

The potential for energy generation depends on the composition, density, moisture content, and presence of inert in the waste. In practice, about 65%–80 % of the energy content of the organic matter can be recovered as heat energy, which can be utilised either for direct thermal applications or for producing power via steam turbine generators.

Besides the potential for energy use, incineration of MSW helps to reduce landfill volumes. Incineration is an option especially where other better options of processing of waste are not feasible and land for landfilling and other waste processing methods is scarce.

### 3.3.3.1 KEY CRITERIA FOR MUNICIPAL SOLID WASTE INCINERATION

MSW incineration projects are appropriate only if the following overall criteria are fulfilled:

- a mature and well-functioning waste management system has been in place for a number of years;
- incineration is especially relevant for the dry bin content in a two-bin system. For unsegregated waste, pre-treatment is necessary;
- the lower calorific value (LCV)<sup>32</sup> of waste must be at least 1,450 kcal/kg (6 MJ/kg) throughout all seasons. The annual average LCV must not be less than 1,700 kcal/kg (7 MJ/kg);<sup>33</sup>
- the furnace must be designed in line with best available technologies to ensure stable and continuous operation and complete burnout of the waste and flue gases. MSW is usually incinerated in a grate incinerator. Uniform combustion of waste is dependent on the grate design. Please refer to section 3.3.3.6.1 for further detail;
- the supply of waste should be stable and amount to at least 500 TPD of segregated waste;
- produced electricity or steam can be sold on a sustainable basis (e.g., feeding into the general grid at adequate tariffs).
- it is possible to absorb the increased treatment cost through management charges and tipping fees.
- skilled staff can be recruited and maintained.
- since the capital investment is very high, the planning framework of the community should be stable enough to allow a planning horizon of 25 years or more.
- pre-feasibility study for the technology lead to positive conclusions for the respective community.
- strict monitoring systems are proposed and followed.



The success of waste incineration projects depends entirely on incoming waste feed characteristics and quantity

32 LCV or net calorific value (NCV) is determined by subtracting the heat of vaporization of the water vapor in the combustion reaction products from the higher heating value or gross calorific value (GCV), giving a lower value than the GCV.

33 Decision Maker's Guide to Municipal Solid Waste Incineration, The World Bank, 1999



To ensure financial viability of incineration plants, the supply of waste feed should be at least 1000 TPD of mixed waste

### 3.3.3.2 KEY CONSIDERATIONS FOR INCINERATION OF MUNICIPAL SOLID WASTE

Incineration of municipal solid waste should meet with the following criteria:

- minimum gas phase combustion temperature of 850°C and a minimum residence time of the flue gases, above this temperature, of two seconds after the last incineration air supply;
- optimum oxygen content (lower than 6%) should be maintained to minimise corrosion and ensure complete combustion. The carbon monoxide content of the flue gas is a key indicator of the quality of combustion;



#### Operational Incineration Plants in India (as of January 2015)<sup>34</sup>

Currently, five waste to energy (WtE) plants are operational or under construction, which are expected to receive grants from the Ministry of New and Renewable Energy (MNRE) as per their Programme on Energy from Urban, Industrial and Agricultural Waste or Residues. MNRE is aiming at compliance with international emission standards for WtE plants in India. Some details of the plants supported by MNRE are given below:

**Delhi:** Timarpur-Okhla Waste Management Company is an initiative of Jindal ITF Ecopolis. The incineration plant was commissioned in January 2012 and is processing about 1,600 TPD of waste. The MSW after pre-processing is being fed into the incineration plant and is generating about 16 megawatts (MW) of electricity.

**Delhi, Ghazipur:** Of the 2,000 TPD of waste received at the landfill, the facility will process about 1,300 TPD to generate 433 TPD of RDF which will be utilised for generation of 12 MW power. The project is under construction. The public private partnership (PPP) operator is Infrastructure Leasing and Financial Services (IL&FS).

**Bengaluru:** An 8-MW power plant is in the process of being set up in Bangalore. This initiative is carried out under a PPP framework between M/s Srinivasa Gayithri Resources Recovery and Bruhat Bengaluru Mahanagara Palike (BBMP). The plant is not yet operational.

**Pune:** A 10-MW WTE plant based on gasification technology is being set up in Pune by Rochem Separation Systems as one of the pilot projects. The plant will utilize 700 TPD of waste for production of 10 MW of electricity. The plant is not yet operational.

**Hyderabad:** An 11-MW power plant will utilize 1,100 TPD of MSW. It is being installed in the Nalgonda district of Telangana by RDF Power Projects. The plant will produce refuse-derived fuel (RDF) for in-house incineration and power generation. The plant is under construction.

<sup>34</sup> Waste incineration for urban India: valuable contribution to sustainable MSWM or inappropriate high-tech solution affecting livelihoods and public health? Dube, R, Nandan, V & Dua, S (2014). Int. J. Environmental Technology and Management, Vol. 17, Nos. 2/3/4 and further updated information by MNRE (2015).





- fly ash acts as catalyst for de novo synthesis (at 200°C–450°C) of dioxins and furans. In order to reduce formation of dioxins and furans, it is imperative that maximum fly ash is removed before gases cool to the range of 200°C–450°C;
- the flue gases produced in the boilers should be treated by an elaborate flue gas treatment system.

### 3.3.3.3 OVERVIEW OF THE INCINERATION PROCESS

The following general description of an incineration plant includes the crucial processing steps and aspects:

- siting of an incineration plant;
- waste reception and handling (storage, on-site pre-treatment facilities);
- combustion and steam generation system;
- flue gas cleaning system;
- energy generation system (steam turbine and generator in case the unit is equipped for WTE recovery);
- residual hauling and disposal system; and
- monitoring and controlling incineration conditions.

In designing each of these process steps, the type(s) of waste that are treated in a concrete installation has to be reflected.

### 3.3.3.4 SITING OF INCINERATION PLANT

The location of a MSW incineration plant should always be determined with respect to both economic and environmental issues. Some of the key criterias for siting an incineration facility are the following:

- a controlled and well-operated landfill must be available for disposing residues (bed and fly ash);
- MSW incineration plants should be located in land-zones dedicated to medium or heavy industry;
- MSW incineration plants should be at least 300–500 meters from residential zones;
- in case of steam production, the plants should be located near suitable energy consumers.



The siting of incineration plants should consider all the following: proximity to waste generation point, traffic and transport, air quality, noise impact, proximity to energy distribution networks, utilities and landfills

Figure 3.23: Typical Mass Burn Incinerator<sup>35</sup>

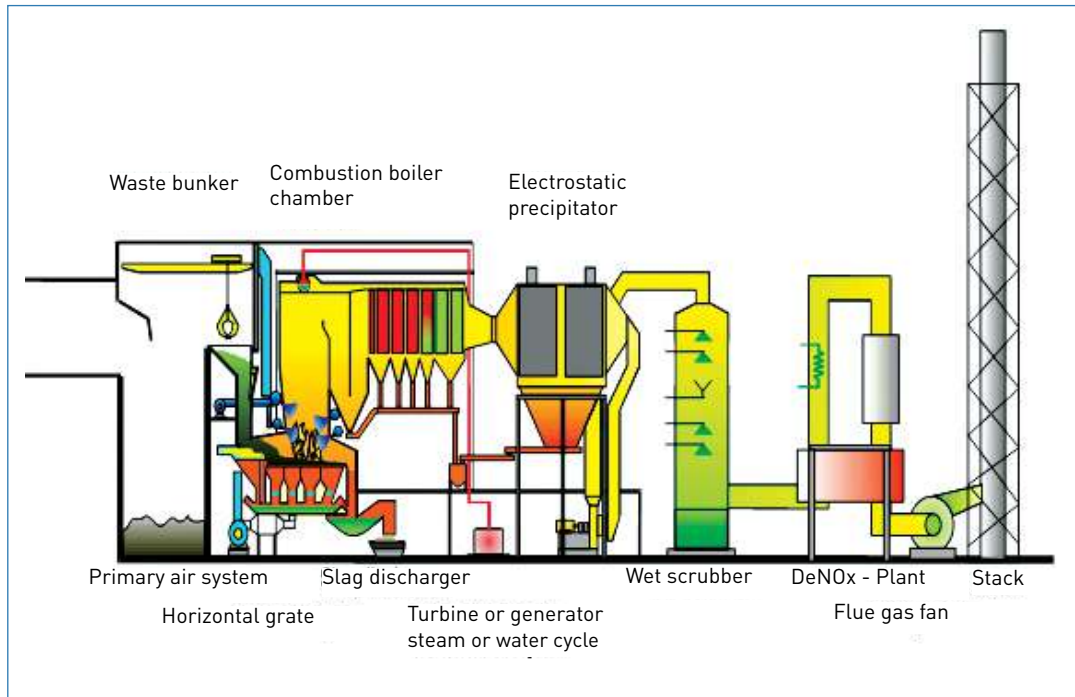

### 3.3.3.5 WASTE RECEPTION AND HANDLING

Figure 3.23 provides an overview of the design of an incineration plant. The incoming waste reception area is usually a waterproof concrete bed which receives waste from vehicles usually after visual control and weighing. Enclosure of the delivery area can be one of the effective means of avoiding odour, noise, and emission problems from the waste.

The waste is piled and mixed in the bunker using cranes equipped with grapples. The mixing of waste helps to achieve a balanced heat value, size, structure, composition, etc. of the material dumped into the incinerator filling hoppers. The bunker must have a storage capacity for at least 3–5 days depending on the plant's operational capacity. The storage area will also depend on local factors and the specific nature of the waste.

**Waste Feeder:** The key objective behind the waste feeder system is to supply exactly the right amount of fuel to the grate that is necessary to achieve minimum negative pressure and desired temperature for stable combustion and energy generation. The feed rate must be constantly and continuously adapted to the transport capacity of the grate to obtain a uniformly distributed layer of fuel on the grate and thus achieve uniform energy generation. Consistent feeding also ensures minimal environmental pollution, especially as it fosters optimal controllable combustion.

35 Waste-Non-Hazardous Waste-Municipal Solid Waste, USEPA (2013).

Waste reception and storage area should be designed in such a way as to allow for daily and weekly variations in the waste quantities and for mixing of waste to achieve balanced heat value, size, composition etc.

Removal of inerts and C&D waste is essential to ensure combustion efficiency

The waste is discharged from the storage bunker into the feeding chute by an overhead crane, and then fed into the grate system by a hydraulic ramp or other conveying systems. The grate moves the waste through the various zones of the combustion chamber in a tumbling motion. The filling hopper is used as a continuous waste supplier. It is filled in batches by the overhead crane. As the filling hopper surface is exposed to great stress, material with high friction resistance are selected (e.g., boilerplates or wear-resistant cast iron). The material must survive occasional hopper fires unscathed. The waste hopper may sometimes be fed by a conveyor. In that case, the overhead crane discharges waste into an intermediate hopper that feeds the conveyor.

It is recommended to divide the total plant capacity into two or more identical incineration lines, thus improving the plant's flexibility and availability—e.g., when one line is closed for maintenance. This is required since the plant needs to be shut down for mandatory maintenance and inspection of boilers for a minimum of 4–6 weeks.

### 3.3.3.6 COMBUSTION AND STEAM GENERATION SYSTEM

Combustion takes place above the grate in the incineration chamber. As a whole, the incineration chamber typically consists of a grate situated at the bottom, cooled and non-cooled walls on the furnace sides, and a ceiling or boiler surface heater at the top. As MSW generally has a high volatile content, the volatile gases are driven off and only a small part of the actual incineration takes place on or near the grate.

The design of the incineration chamber depends on the following:

- Form and size of the incineration grate. The size of the grate determines the size of the cross-section of the incineration chamber.
- Vortexing and homogeneity of flue gas flow. Complete mixing of the flue gases is essential for good flue gas incineration.
- Residence time for the flue gases in the hot furnace. Sufficient reaction time at high temperatures must be assured for complete incineration.
- Partial cooling of flue gases. In order to avoid fusion of hot fly ash at the boiler, the flue gas temperature must not exceed an upper limit at the incineration chamber exit.

The detailed design of a combustion chamber is usually linked to the grate type. Its precise design demands certain compromises as the process requirements change with the fuel characteristics.



Waste feeder systems should be designed to maintain optimum combustion, resulting in minimal environmental pollution



Typical incineration chamber consists of:

- grate at the bottom
- cooled and non-cooled walls
- ceiling or boiler surface heater at the top

Grate incinerators are best suited for MSW that is mixed, non-homogenous and has low calorific value

### 3.3.3.6.1 Grate Incinerators

The incineration grate accomplishes the following functions:

- transport of material to be incinerated through the furnace;
- stoking and loosening of the material to be incinerated; and
- positioning of the main incineration zone in the incineration chamber, possibly in combination with furnace performance control measures.

**Figure 3.24: Grate Furnace and Heat Recovery Stages of a Municipal Waste Incineration Plant<sup>36</sup>**

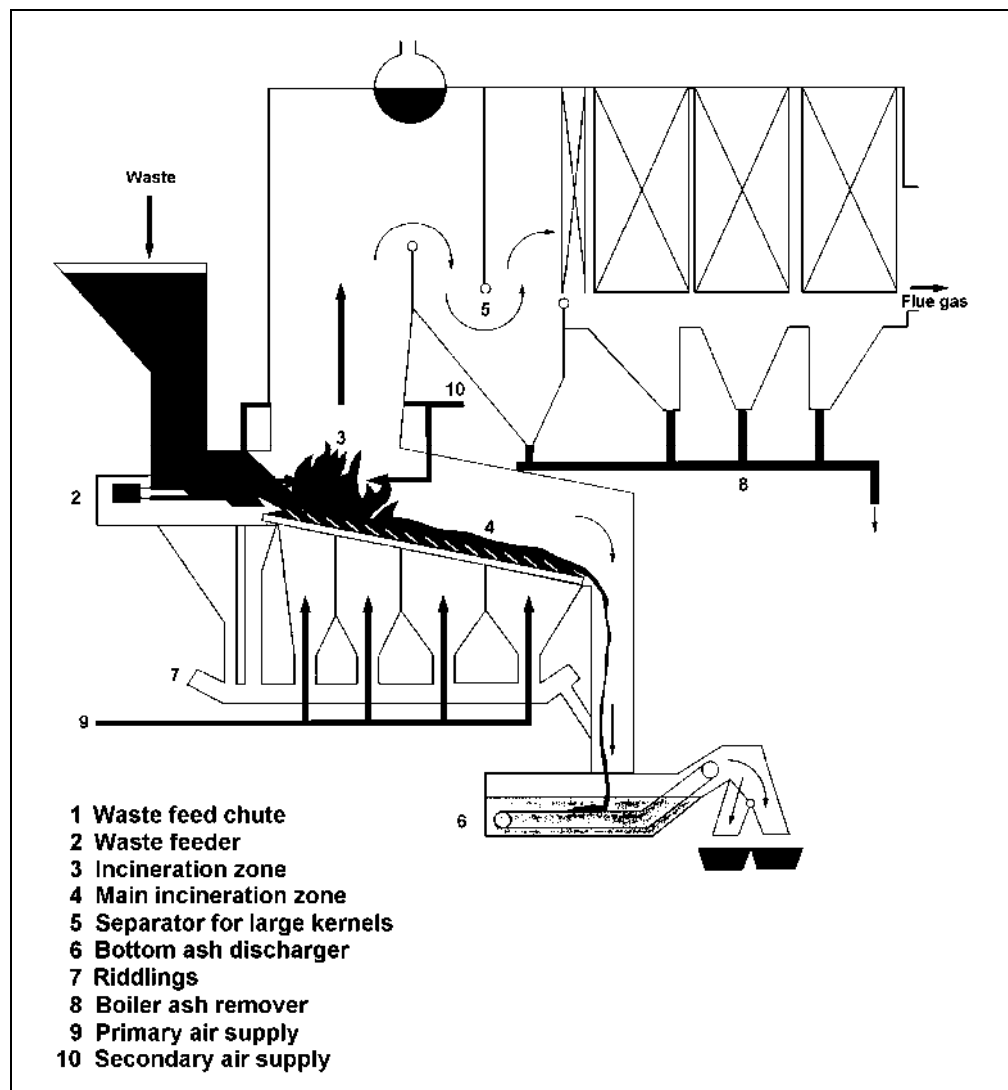

Grate incinerators (Figure 3.24) are widely applied for the incineration of mixed municipal wastes and can be used for untreated, non-homogenous, and low calorific municipal waste. An overhead crane feeds waste into the hopper, where it is transported via the chute to the

36 "Reference Document on the Best Available Techniques for Waste Incineration", European Commission (2006). Available at: <http://eippcb.jrc.ec.europa.eu/reference/wi.html>

grate in the furnace. On the grate, the waste is dried and then burned at high temperature with supply of air. The ash, including noncombustible fractions of waste, leaves the grate as slag or bottom ash through the ash chute.

Different grate systems can be distinguished by the way the waste is conveyed through the different zones in the combustion chamber. The type of grate system determines the efficacy of primary air feeding, conveying velocity and raking, as well as mixing of the waste.

#### Advantages of Grate Incinerators:



- There is no need for prior sorting or shredding.
- Technology is widely tested and meets the standards of technical performance.
- It accommodates large variations in waste composition and calorific value.
- It allows for an overall thermal efficiency of up to 85%.

#### Disadvantage of grate incinerators:

- Capital and maintenance costs are relatively high.

**Reciprocating grates:** Many modern MSWM incinerator facilities use reciprocating grates. The quality of burnout achieved is generally good. Reciprocating grates consist of sections that span the width of the furnace but are stacked above each other. Alternate grate sections slide back and forth, while the adjacent sections remain fixed. Waste tumbles off the fixed portion and is agitated and mixed as it moves along the grate.

There are essentially two main reciprocating grate variations:

1. **Reverse reciprocating grate:** The grate bars oscillate back and forth in the reverse direction to the flow of the waste. The grate is sloped from the feed end to the ash discharge end and is comprised of fixed and moving grate steps.
2. **Push forward grate:** The grate bars form a series of many steps that oscillate horizontally and push the waste in the direction of the ash discharge.

Other grate types that have been in use include rocking grates, travelling grates, roller grates, and cooled grates.



Timarpur Okhla Municipal Solid Waste Management Project is one of the few waste-to-energy (WTE) facility in India which is using a reciprocating forward moving grate incinerator for combustion of mixed solid waste of Delhi.

Grate incinerators are of two types:

- **Moving grate furnace system:** waste enters from one end while ash is discharged at other
- **Fixed grates:** series of steps with drying stage and initial combustion phase, complete combustion and final carbon burn-out



Other types of incinerators including the fluidised bed incinerator and rotary kiln incinerator are not suitable for mixed municipal solid waste (MSW) incineration. Rotary kiln incinerators are typically used for incineration of hazardous waste and biomedical waste.

### 3.3.3.7 INCINERATOR AIR FEEDING

The incineration air fulfills the following objectives:

- provision of oxidant
- cooling
- avoidance of slag formation in the furnace
- mixing of flue-gas

Air is added at various places in the combustion chamber; depending on the location, it is described as primary and secondary air. Tertiary air and re-circulated flue gases may also be used.

Primary air is generally taken from the waste bunker. This lowers the air pressure in the bunker hall and eliminates most odour emissions from the bunker area. This primary air is blown by fans into the areas below the grate, where its distribution can be closely controlled using multiple wind boxes and distribution valves. Primary air is forced through the grate into the fuel bed. It cools the grate bar to preserve structural integrity of the grate and carries oxygen into the incineration bed.

Secondary air is blown into the incineration chamber at high speed via, for example, injection lances or internal structures. This is carried out to secure complete incineration and is responsible for the intensive mixing of flue gases and prevention of the free passage of unburned gas streams.

### 3.3.3.8 FLUE GAS RECIRCULATION

Flue gas recirculation is an integral part of the furnace design. After passing through the dust filter, part of the flue gas is retained and recirculated through an insulated duct to the furnace. The recirculated flue gas is injected through separate nozzles in the furnace. The primary advantages of flue gas recirculation are the following:

- 10%–20% of secondary combustion air can be replaced with flue gas.
- Mono-nitrogen oxides ( $\text{NO}_x$ ) reduction is achieved because the supplied re-circulated flue gases have lower oxygen concentration and, therefore, lower flue gas temperature, which leads to a decrease of the nitrogen oxide levels.



Flue gas recirculation has its operational, economic and environmental advantages

- It stabilises and improves the flow and turbulence conditions, particularly at partial load.

### 3.3.3.9 RESIDUAL HAULAGE AND DISPOSAL SYSTEM

During the incineration process, most of the waste is combusted and converted to gases such as carbon dioxide (CO<sub>2</sub>), water vapor, and toxic gases, which are cleaned through a complex flue gas treatment system. However, part of the waste is incombustible and is removed from the incineration furnace as slag or bottom ash, a solid residue. The amount of slag generated depends on the composition of the waste and amounts to 20%–25% by weight of the waste combusted.

The flue gas cleaning process also produces residues, either directly (fly ash) or by the subsequent treatment of the spent scrubbing liquids, depending on the flue gas cleaning method applied. Fly ash from filter systems is highly contaminated and, hence, care must be taken to collect bottom ash and fly ash separately. Bottom ash can be treated for further use.

The slag from a well-operated waste incinerator will be well burned out, with only a minor content of organic material. Besides, the heavy metals in the slag, which are normally leachable, will, to some extent, become vitrified and thus insoluble.

Bottom ash may be treated either on-site or off-site by a dry system or wet system suitably combined with or without ageing. Dry bottom ash treatment installations combine the techniques of ferrous metals separation, size reduction and screening, nonferrous metals separation, and ageing of the treated bottom ash, usually for 6–20 weeks. The product is a dry aggregate which can be used as a secondary construction material.

Wet bottom ash treatment system in the ash quench tank allows the production of a material for recycling with minimal leachability of metals. The economy of the bottom ash treatment depends on the market price of the produced fractions. Revenue can be generated by the sale of nonferrous and ferrous metals fractions.

The fly ash generated in the boilers (approximately 1%–2% of input MSW quantity) and air pollution control equipment is highly contaminated and must be disposed appropriately. Since the salt and heavy metal content is very high in the ash, it cannot be used for construction purposes. Depending on the heavy metals constituents of fly ash, it should be appropriately mixed with binding agents like cement which would reduce the solubility of heavy metals, thus preventing their leaching and making the safe disposal of fly ash possible. If the treatment, storage, and disposal facility (TSDF) is not available, then

Fly ash should be transported in 'silos' and disposed in hazardous landfill

Residual wastes from incinerators like slag could be used as road construction material while fly ash from flue gas cleaning should be disposed in hazardous landfill

solidified and stabilised fly ash blocks should be disposed in an identified cell of municipal sanitary landfill.

### 3.3.3.10 CONSUMPTION OF RAW MATERIALS AND ENERGY BY INCINERATION PLANTS

Waste incineration plants (process dependent) may consume:

- electricity, for process plant operation;
- heat, for specific process needs;
- fuels, support fuels (e.g., gas, light oils, coal, char);
- water, for flue gas treatment, cooling, and boiler operation;
- flue gas treatment reagents, e.g., caustic soda, lime, sodium bicarbonate, sodium sulfite, hydrogen peroxide, activated carbon, ammonia, and urea;
- water treatment reagents, e.g., acids, alkalis, trimercapto triazine, sodium sulphite, etc.; and
- high pressure air, for compressors.

State of the art incinerator technology and flue gas treatment system coupled with strict monitoring would ensure environmentally safe incinerator facilities

### 3.3.3.11 ENVIRONMENTAL CONSIDERATIONS

MSW incineration produces a range of volatile and gaseous emissions, which, if untreated and released to the atmosphere, can compromise environment quality. Fly ash and dust carry toxic contaminants. Ash leachate might contaminate soil and water.

The actual range of emissions depends on the specific characteristics of the waste stream and engineering design of the plant such as combustion temperature, combustion chamber design, and ancillary emission abatement technologies. Proper planning to minimise environmental damage as well as public education and involvement are essential to successful incineration programmes.

MSW incinerators pose environmental risks through potential emission of contaminants and ash leachate that could contaminate soil and water

### 3.3.3.12 EMISSION REDUCTION IN INCINERATORS

Incineration of MSW generates large volumes of flue gases, which carry ash, heavy metals, and a wide range of organic and inorganic compounds. Major air emissions from MSW incinerators include hydrogen chloride, hydrogen fluoride, sulphur dioxide,  $\text{NO}_x$ , carbon monoxide, volatile organic compound, heavy metals, etc., which are hazardous to human health and environment. Dioxins and furans are especially potent and need to be controlled through appropriate operating conditions and flue gas treatment technology.



Primary control measures include initiatives that actually retard the formation of pollutants, especially NO<sub>x</sub> and dioxins:

- efficient combustion process
  - with long flue gas retention duration at high temperature
  - appropriate oxygen content
  - intensive mixing
  - recirculation of flue gas
- precipitation of ashes in the boiler
- short flue gas retention time at intermediate temperature

Secondary measures include installation of air pollution control equipment which comprise of bag house filters, dry, acid gas removal systems, catalytic reduction systems etc. Table 3.10 briefly describes available emission control technologies for different constituents of flue gas.

**Table 3.10: Air Emission Control Technologies<sup>37</sup>**

| FLUE GAS CONSTITUENTS  | TECHNOLOGY DESCRIPTION   |
|--|--|
| Total dust   | <p>Effective maintenance of dust control systems is very important. Controlling dust levels generally reduces metal emissions too.</p> <p>Flue gas treatment (FGT) (pre-dust control before FGT): bag filters, ESPs, cyclones, and multi-cyclones</p> <p>Additional flue gas polishing system: bag filters, wet electrostatic precipitator (ESP), electro dynamic venture scrubbers, agglomeration modules, ionizing wet scrubber</p>                    |
| Hydrogen chloride (HCl), hydrogen fluoride (HF), sulphur dioxide (SO <sub>2</sub> )                                      | <p>Waste control: Blending and mixing can reduce fluctuations in raw gas concentrations that can lead to elevated short-term emissions.</p> <p>FGT: Wet flue gas treatment systems generally have the highest absorption capacity and deliver the lowest emission levels for these substances, but are more expensive and difficult to maintain.</p>   |
| Nitrogen monoxide (NO) and nitrogen dioxide (NO <sub>2</sub> ), expressed as NO <sub>2</sub> for installations using SCR | <p>Waste and combustion control techniques coupled with selective catalytic reduction (SCR) generally result in operation within acceptable emission ranges. The use of SCR imposes an additional energy demand and costs. In general, at larger installations, the use of SCR results in less significant additional cost per ton of waste treated. Waste with high nitrogen content may result in increased raw gas NO<sub>x</sub> concentrations.</p> |
| Nitrogen monoxide (NO) and NO <sub>2</sub> , expressed as NO <sub>2</sub> for installations using SNCR                   | <p>Waste and combustion control techniques with selective non-catalytic reduction (SNCR) generally result in operation within acceptable emission ranges.</p>  |

37 "Reference Document on the Best Available Techniques for Waste Incineration", European Commission (2006). Available at: <http://eippcb.jrc.ec.europa.eu/reference/wi.html>

**Table 3.10: Air Emission Control Technologies [contd.]**

| <b>FLUE GAS CONSTITUENTS</b>   | <b>TECHNOLOGY DESCRIPTION</b>   |
|--|---|
| Gaseous and vaporous organic substances, expressed as total organic carbon (TOC) or carbon monoxide (CO)   | Techniques that improve combustion conditions reduce emissions of these substances. Carbon monoxide levels may be higher during start-up and shutdown, and with new boilers that have not yet established their normal operational fouling level.   |
| Mercury (Hg) and its compounds   | Adsorption using carbon based reagents is generally required to achieve these emission levels with many wastes- as metallic Hg is more difficult to control than ionic Hg. The precise abatement performance and technique required will depend on the levels and distribution of Hg in the waste. Some waste streams have very highly variable Hg concentrations; waste pre-treatment may be required in such cases to prevent peak overloading of flue gas circulation system capacity. |
| Cadmium (Cd) and thallium (Tl)   | Dust and other metal control methods are more effective at controlling these substances.  |
| Other metals   | Techniques that control dust levels generally also control these metals.  |
| Polychlorinated dibenzodioxins (PCDDs) and polychlorinated dibenzofurans (PCDFs), expressed as nanograms of dioxin toxic equivalent per normal cubic meter (ng TEQ/Nm <sup>3</sup> ) | Combustion techniques destroy PCDD and PCDF in the waste.<br>Specific design and temperature controls reduce de novo synthesis.<br>FGT: static activated carbon filters or activated carbon is injected into the gas flow. The carbon is filtered from the gas flow using bag filters. The activated carbon shows a high absorption efficiency for mercury as well as for PCDD and PCDF.<br>Catalytic bag filters are also used to reduce concentrations of PCDD and PCDF.                |
| Ammonia (NH <sub>3</sub> )   | Effective control of NO <sub>x</sub> abatement systems, including reagent dosing contributes to reducing ammonia emissions.   |
| Benzo(a)pyrene, polychlorinated biphenyls (PCBs), polycyclic aromatic hydrocarbons (PAHs)  | Techniques that control PCDD and PCDF also control Benzo(a) pyrene, PCBs, and PAHs.   |
| Nitrous oxide (N <sub>2</sub> O)   | Effective oxidative combustion and control of NO <sub>x</sub> abatement systems contribute to reducing nitrous oxide emissions.   |

### 3.3.3.13 MONITORING REQUIREMENTS

The SWM Rules, 2016 provide emission standards for incineration.



**Schedule II (C): Standards for Incineration:**

**Emission standards.**

The stack emission standards for Incinerator/Thermal technologies in solid waste treatment/disposal facility:-

**Table 3.11: The Stack Emission Standards for Treatment and Utilisation of Municipal Solid Waste Using Incinerator or Thermal Technologies**

| PARAMETER  | EMISSION STANDARD          |  |
|--|----------------------------|--|
| Particulates   | 50 mg/Nm <sup>3</sup>      | Standard refers to half hourly average value.  |
| HCl  | 50 mg/Nm <sup>3</sup>      | Standard refers to half hourly average value.  |
| SO <sub>2</sub>  | 200 mg/Nm <sup>3</sup>     | Standard refers to half hourly average value.  |
| CO   | 100 mg/Nm <sup>3</sup>     | Standard refers to half hourly average value.  |
|  | 50 mg/Nm <sup>3</sup>      | Standard refers to daily average value.  |
| Total Organic Carbon (TOC)   | 20 mg/Nm <sup>3</sup>      | Standard refers to half hourly average value.  |
| HF   | 4 mg/Nm <sup>3</sup>       | Standard refers to half hourly average value.  |
| NO <sub>x</sub> (NO and NO <sub>2</sub> expressed as NO <sub>2</sub> ) | 400 mg/Nm <sup>3</sup>     | Standard refers to half hourly average value.  |
| Total dioxins and furans   | 0.1 ng TEQ/Nm <sup>3</sup> | Standard refers to 6–8 hours sampling. Please refer guidelines for 17 concerned congeners for toxic equivalence values to arrive at total toxic equivalence. |
| Cd + Th + their compounds  | 0.05 mg/Nm <sup>3</sup>    | Standard refers to sampling time anywhere between 30 minutes and 8 hours.  |
| Hg and its compounds   | 0.05 mg/Nm <sup>3</sup>    | Standard refers to sampling time anywhere between 30 minutes and 8 hours.  |
| Sb + As + Pb + Cr + Co + Cu + Mn + Ni + V + their compounds            | 0.5 mg/Nm <sup>3</sup>     | Standard refers to sampling time anywhere between 30 minutes and 8 hours.  |

**Note:**

- (a) Suitably designed pollution control devices shall be installed or retrofitted with the incinerator to achieve the above emission limits.
- (b) Waste to be incinerated shall not be chemically treated with any chlorinated disinfectants. (c) Incineration of chlorinated plastics shall be phased out within two years.
- (d) if the concentration of toxic metals in incineration ash exceeds the limits specified in the Hazardous Waste (Management, Handling and Trans boundary Movement) Rules, 2008, as amended from time to time, the ash shall be sent to the hazardous waste treatment, storage and disposal facility.
- (e) Only low sulphur fuel like LDO, LSHS, Diesel, bio-mass, coal, LNG, CNG, RDF and bio-gas shall be used as fuel in the incinerator.
- (f) The CO<sub>2</sub> concentration in tail gas shall not be more than 7%.
- (g) All the facilities in twin chamber incinerators shall be designed to achieve a minimum temperature of 950 °C in secondary combustion chamber and with a gas residence time in secondary combustion chamber not less than 2 (two) seconds.
- (h) Incineration plants shall be operated (combustion chambers) with such temperature, retention time and turbulence, as to achieve total Organic Carbon (TOC) content in the slag and bottom ash less than 3%, or the loss on ignition is less than 5% of the dry weight.
- (i) Odour from sites shall be managed as per guidelines of CPCB issued from time to time
- (j) All values corrected to 11% oxygen on a dry basis.

The Central Pollution Control Board (CPCB) shall prescribe standards for maintenance of ambient air quality and permissible levels of dioxins and furans around the waste to energy (WtE) plants other than small facilities, treating less than 5 TPD waste, and circulate the same to all State Pollution Control Board (SPCB) and committees for uniform application.

The SPCB or committee shall prescribe standards for maintenance of ambient air quality and permissible levels of dioxins and furans around the waste to energy plants in consonance with the emission standards prescribed by the CPCB. If the proposal includes the technology other than the one for which standards have been prescribed by the CPCB, the SPCB or committee shall forward the proposal with its recommendations to CPCB or prescribing suitable standards.

As waste processing plants are often near a city or even within it, it is necessary to have stringent standards for emission control in order to safeguard public health and environment. It is desirable that for existing plants, a time frame of about 3 years may be set for conversion into the new norms.

International air emission (European Union) standards for MSW based incineration plants are more stringent as compared with those in the SWM Rules, 2016. Consolidated Emission norms from EU-Directive on the incineration of wastes (2000/76/EC) and its subsequent amendments.<sup>38</sup> As mentioned in Table 3.12.

**Table 3.12: Emission Norms for Incineration of Municipal Solid Waste as per European Union Directive**

|   |                       |
|---|-----------------------|
| [a] Daily average values:   |                       |
| Total dust  | 10 mg/m <sup>3</sup>  |
| Gaseous and vaporous organic substances, expressed as total organic carbon (TOC)  | 10 mg/m <sup>3</sup>  |
| Hydrogen chloride (HCl)   | 10 mg/m <sup>3</sup>  |
| Hydrogen fluoride (HF)  | 1 mg/m <sup>3</sup>   |
| Sulphur dioxide (SO <sub>2</sub> )  | 50 mg/m <sup>3</sup>  |
| Nitrogen monoxide (NO) and nitrogen dioxide (NO <sub>2</sub> ) expressed as nitrogen dioxide for existing incineration plants with a nominal capacity of 6 tonnes per hour or new incineration plants | 200 mg/m <sup>3</sup> |
| Nitrogen monoxide (NO) and nitrogen dioxide (NO <sub>2</sub> ) expressed as nitrogen dioxide for existing incineration plants with a nominal capacity of 6 tonnes per hour or less                    | 400 mg/m <sup>3</sup> |
| [*] Until 1 January 2007 and without prejudice to relevant (Community) legislation the emission limit value for NO <sub>x</sub> does not apply to plants only incinerating hazardous waste.           |                       |
| Exemptions for NO <sub>x</sub> may be authorised by the component authority for existing incineration plants.   |                       |

38 Directive of the European Parliament and of the Council on the Incineration of Waste (2000). Available at <http://eur-lex.europa.eu/LexUriServ/LexUriServ.do?uri=CONSLEG:2000L0076:20081211:EN:PDF>

**Table 3.12: Emission Norms for Incineration of MSW as per EU Directive [contd.]**

|   |                               |                                  |
|---|-------------------------------|----------------------------------|
| * with a nominal capacity of 6 tonnes per hour, provided that the permit foresees the daily average values do not exceed 500 mg/m <sup>3</sup> and this until 1 January 2008.   |                               |                                  |
| * with a nominal capacity of >6 tonnes per hour but equal or less than 16 tonnes per hour, provided the permit foresees the daily average values do not exceed 400 mg/m <sup>3</sup> and this until 1 January 2010.   |                               |                                  |
| * with a nominal capacity of >16 tonnes per hour but <25 tonnes per hour and which do not produce water discharges, provided that the permit foresees the daily average values do not exceed 400 mg/m <sup>3</sup> and this until 1 January 2008.   |                               |                                  |
| * Until 1 January 2008, exemptions for dust may be authorised by the competent authority for existing incinerating plants, provided that the permit foresees the daily average values do not exceed 20 mg/m <sup>3</sup> .  |                               |                                  |
| <b>(b) Half-hourly average values:</b>  |                               |                                  |
|   | (100%) A                      | (97 %) B                         |
| Total dust  | 30 mg/m <sup>3</sup>          | 10 mg/m <sup>3</sup>             |
| Gaseous and vaporous organic substances, expressed as total organic carbon (TOC)  | 20 mg/m <sup>3</sup>          | 10 mg/m <sup>3</sup>             |
| Hydrogen chloride (HCl)   | 60 mg/m <sup>3</sup>          | 10 mg/m <sup>3</sup>             |
| Hydrogen fluoride (HF)  | 4 mg/m <sup>3</sup>           | 2 mg/m <sup>3</sup>              |
| Sulphur dioxide (SO <sub>2</sub> )  | 200 mg/m <sup>3</sup>         | 50 mg/m <sup>3</sup>             |
| Nitrogen monoxide (NO) and nitrogen dioxide (NO <sub>2</sub> ), expressed as nitrogen dioxide for existing incineration plants with a nominal capacity exceeding 6 tonnes per hour or new incineration plants   | 400 mg/m <sup>3</sup><br>(* ) | 200 mg/m <sup>3</sup><br>(* )    |
| (*) Until 1 January 2007 and without prejudice to relevant Community legislation the emission limit value for NO <sub>x</sub> , does not apply to plants only incinerating hazardous waste.   |                               |                                  |
| Until 1 January 2010, exemptions for NO <sub>x</sub> may be authorised by the competent authority for existing incineration plants with a nominal capacity between 6 and 16 tonnes per hour, provided the half-hourly average value does not exceed 600 mg/m <sup>3</sup> for column A or 400 mg/m <sup>3</sup> for column B. |                               |                                  |
| <b>(c) All average values over the sample period of a minimum of 30 minutes and a maximum of 8 hours:</b>   |                               |                                  |
| Cadmium and its compounds, expressed as cadmium (Cd)  | Total 0.05 mg/m <sup>3</sup>  | Total 0,1 mg/m <sup>3</sup> (* ) |
| Thallium and its compounds, expressed as thallium (Tl)  |                               |                                  |
| Mercury and its compounds, expressed as mercury (Hg)  | 0.05 mg/m <sup>3</sup>        | 0.1 mg/m <sup>3</sup>            |
| Antimony and its compounds, expressed as antimony (Sb)  | total 0.5 mg/m <sup>3</sup>   | total 1 mg/m <sup>3</sup> (* )   |
| Arsenic and its compounds, expressed as arsenic (As)  |                               |                                  |
| Lead and its compounds, expressed as lead (Pb)  |                               |                                  |
| Chromium and its compounds, expressed as chromium (Cr)  |                               |                                  |
| Cobalt and its compounds, expressed as cobalt (Co)  |                               |                                  |
| Copper and its compounds, expressed as copper (Cu)  |                               |                                  |
| Manganese and its compounds, expressed as manganese (Mn)  |                               |                                  |
| Nickel and its compounds, expressed as nickel (Ni)  |                               |                                  |
| Vanadium and its compounds, expressed as vanadium (V)   |                               |                                  |
| (*) Until 1 January 2007 average values for existing plants for which the permit to operate has been granted before 31 December 1996, and which incinerate hazardous waste only.  |                               |                                  |

**Table 3.12: Emission Norms for Incineration of MSW as per EU Directive [contd.]**

|   |                       |  |
|---|-----------------------|--|
| These average values cover also gaseous and the vapour forms of the relevant heavy metal emissions as well as their compounds.  |                       |  |
| (d) Average values shall be measured over a sample period of a minimum of 6 hours and a maximum of 8 hours. The emission limit value refers to the total concentration of dioxins and furans calculated using the concept of toxic equivalence:                       |                       |  |
| Dioxins and furans  | 0.1 ng/m <sup>3</sup> |  |
| (e) The following emission limit value of carbon monoxide (CO) concentrations shall not be exceeded in the combustion gases (excluding the start-up and shut-down phase):   |                       |  |
| 50 milligrams/m <sup>3</sup> of combustion gas determined as daily average value.   |                       |  |
| 150 milligrams/m <sup>3</sup> of combustion gas of at least 95% of all measurement determined as 10-minute average values or 100 mg/m <sup>3</sup> of combustion gas of all measurements determined as half-hourly average values taken in any 24-hour period.        |                       |  |
| Exemptions may be authorised by the competent authority for incineration plants using fluidised bed technology, provided that the permit foresees an emission limit value for carbon monoxide (CO) of not more than 100 mg/m <sup>3</sup> as an hourly average value. |                       |  |

### 3.4 BIOMETHANATION

Biomethanation is the anaerobic (in the absence of free oxygen) fermentation of biodegradable matter in an enclosed space under controlled conditions of temperature, moisture, pH, etc. The waste mass undergoes decomposition due to microbial activity, thereby generating biogas comprising mainly of methane and carbon dioxide (CO<sub>2</sub>), and also digested sludge, which is almost stabilised but may contain some pathogen. Due to the anaerobic environment, hydrogen sulfide (H<sub>2</sub>S) is generated with varying percentage depending on the sulphur content in the system (in the form of protein, sulphate, etc.). Like composting, biomethanation is one of the most technically viable options for Indian municipal solid waste (MSW) due to the presence of high organic and moisture content.

Simple small to medium scale systems have been developed in India, especially for cattle manure; these plants are called Gobar Gas Plants. According to the Ministry of New and Renewable Energy (MNRE), 4.3 million family type biogas plants have been installed in India. Toilet linked biogas plants have been installed at family, community, and institutional levels. Application of biomethanation for MSW can be seen broadly in three categories: (i) small biogas plants for canteen waste; (ii) medium-sized digesters for market waste (flower, fruit, vegetable, slaughterhouse, etc.); (iii) and large-scale plants.

There are some well-known examples of installation of MSW based biogas plants: (i) 16 tonnes MSW plus 4 tonnes per day (TPD) slaughterhouse waste based facility in Vijayawada; (ii) 30 TPD flower-fruit market waste based biogas plant in Koyambedu, Chennai; and (iii) 500 TPD MSW based facility at Lucknow. So far, large biogas plants fed with MSW have not been successful in India although such plants have been successful in some other countries. The failure of MSW based biogas plants is not related to the basic technology; this is more due to lack of understanding of the process and planning capability and due to mismatch between the expectations of the concessionaire and the consignee with respect to quality and quantity of MSW supply. However, there are ongoing attempts by different urban local bodies (ULBs) to set up MSW based biogas plants. Medium to large digesters are appropriately designed and engineered for smooth operation. Different designs and models of biogas plants are discussed later.

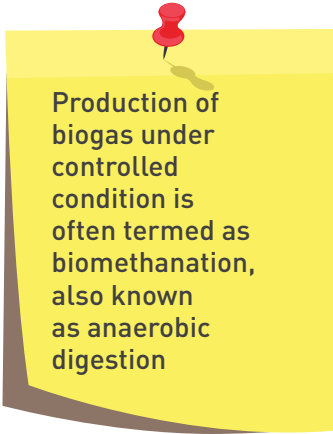

Production of biogas under controlled condition is often termed as biomethanation, also known as anaerobic digestion

### 3.4.1 SOLID WASTE MANAGEMENT RULES, 2016: GUIDANCE ON BIOMETHANATION



As per SWM Rules, 2016:

Clause 15: Duties and responsibilities of local authorities:-

- (m) collect waste from vegetable, fruit, flower, meat, poultry and fish market on day to day basis and promote setting up of decentralised compost plant or biomethanation plant at suitable locations in the markets or in the vicinity of markets ensuring hygienic conditions;
- (t) involve communities in waste management and promotion of home composting, bio-gas generation, decentralised processing of waste at community level subject to control of odour and maintenance of hygienic conditions around the facility;
- (v) facilitate construction, operation and maintenance of solid waste processing facilities and associated infrastructure on their own or with private sector participation or through any agency for optimum utilisation of various components of solid waste adopting suitable technology including the following technologies and adhering to the guidelines issued by the Ministry of Urban Development from time to time and standards prescribed by the Central Pollution Control Board. Preference shall be given to decentralised processing to minimize transportation cost and environmental impacts such as-
  - a) biomethanation, microbial composting, vermi-composting, anaerobic digestion or any other appropriate processing for bio-stabilisation of biodegradable wastes;



#### Clause 4: Duties of waste generator:-

- (6) All resident welfare and market associations shall, within one year from the date of notification of these rules and in partnership with the local body ensure segregation of waste at source by the generators as prescribed in these rules, facilitate collection of segregated waste in separate streams, handover recyclable material to either the authorised waste pickers or the authorised recyclers. The bio-degradable waste shall be processed, treated and disposed off through composting or biomethanation within the premises as far as possible. The residual waste shall be given to the waste collectors or agency as directed by the local body.
- (7) All gated communities and institutions with more than 5,000 sqm area shall, within one year from the date of notification of these rules and in partnership with the local body, ensure segregation of waste at source by the generators as prescribed in these rules, facilitate collection of segregated waste in separate streams, handover recyclable material to either the authorised waste pickers or the authorised recyclers. The bio-degradable waste shall be processed, treated and disposed off through composting or biomethanation within the premises as far as possible. The residual waste shall be given to the waste collectors or agency as directed by the local body.
- (8) All hotels and restaurants shall, within one year from the date of notification of these rules and in partnership with the local body ensure segregation of waste at source as prescribed in these rules, facilitate collection of segregated waste in separate streams, handover recyclable material to either the authorised waste pickers or the authorised recyclers. The bio-degradable waste shall be processed, treated and disposed off through composting or biomethanation within the premises as far as possible. The residual waste shall be given to the waste collectors or agency as directed by the local body.

#### 3.4.2 MERITS OF BIOMETHANATION PROCESS

- Energy generation, the produced biogas can be used for cooking or for the production of electricity and heat.
- Biogas may also be cleaned by removing  $\text{CO}_2$  and  $\text{H}_2\text{S}$ . The resulting methane enriched biogas containing more than 90% methane ( $\text{CH}_4$ ) is somewhat like compressed natural gas (CNG). However, for this gas to be used as automotive fuel, the percentage of  $\text{CO}_2$  has to be less than 5%, which corresponds to methane percentage of 95% or more.  $\text{H}_2\text{S}$  has to be less than 10 parts per million (ppm) for use in automobiles. Use of this fuel is more benign for the environment than using petroleum-based automotive fuels. Like composting,



biomethanation also leads to reduced landfill requirement, thus extending the life of existing landfills.

- Biomethanation of biodegradable organic material would result in stabilised sludge which can be used as a soil conditioner and fertiliser. However, pathogen kill or inactivation may not be complete during anaerobic digestion with the relatively short hydraulic retention time (HRT) designed for optimisation of biogas production. Therefore, aerobic composting of the sludge is recommended to pass the material through temperature cycle of above 60°C–70°C for at least 2 days.
- Although the total system of biomethanation is more cost intensive than the total system of open aerobic composting, biomethanation has certain advantages with respect to much less odour and bird menace. The time frame (cycle time) is also less, so that less land is required for the same capacity. These two can be a big advantage where the only available sites are close to habitation. This way, biomethanation can be compared to in-vessel composting, which is again more expensive than open aerobic composting.

### 3.4.3 APPLICABILITY OF BIOMETHANATION

- Biomethanation is ideal for wet organic wastes, e.g., cooked food. Biomethanation plants require a consistent source of degradable organic matter, free from inert and toxic material. Slaughterhouse waste is eminently suitable for biomethanation.
- Odour problems are also considerably reduced by adopting biomethanation. If the proposed waste processing site is in close proximity to residential areas, biomethanation is a preferred treatment option, especially considering odour issues.
- Anaerobic digestion technology can be adopted in both
  - decentralised systems—up to 5 TPD (much smaller quantities can be processed where O&M is not outsourced); and
  - centralised systems—in modules of up to 50 TPD digesters (for higher capacity in one digester, the size may become unwieldy and difficult to maintain).
- The design of the plant has to be done according to the substrate (feed material) for smooth functioning. The next most important challenge is to make the digester leak-proof. Proper O&M is a critical factor for ensuring the success of the biogas plant which can be achieved through a well-defined standard operating procedure (SOP). Economic viability of the plants is ensured when there is a sustainable and viable market for the generated biogas in the vicinity of the plant and the sludge manure produced during the process.

### 3.4.4 GENERAL PROCESS INVOLVED IN BIOMETHANATION

Generally the overall process can be divided into four stages:

- pre-treatment
- anaerobic fermentation
- collection of biogas and its usage
- residue treatment

**Pre-treatment:** Most digestion systems require pre-treatment of waste to obtain a homogeneous feedstock. For anaerobic fermentation, pre-processing involves separation of non-digestible material either through source segregation (e.g., two-bin system; see Section 2.2 of Part II) or through mechanical sorting at the biogas plant facility. Source segregation results in less contaminated sludge compost. The separation ensures the removal of undesirable or recyclable material such as glass, metals, stones, etc. The waste is shredded before it is fed into the digester for better fermentation especially when the incoming material has large pieces or whole items.

**Anaerobic Fermentation (Digestion):** Anaerobic fermentation happens in three steps brought about by different groups of microbes: hydrolysis (hydrolytic bacteria), acidogenesis (acidogenic bacteria), and finally biomethanation (methanogenic bacteria). Normally the digesters (fermenters) are designed as single stage or single phase, where all the three processes take place in micro environments within the single vessel. Later, the concept of biphasic fermenters were developed where the process up to acidogenesis happens in the first phase in a slightly lower pH range and the methanogenesis happens in the second phase at near neutral pH range. This mode is supposed to be more efficient from the point of pH as well as time management because of the flexibility to optimise each of these reactions.

However, for MSW, the normal practice is to use suspended particulate fermenter configuration in one digester or two digesters in tandem. In the latter case, the efficiency as well as effluent quality improves. The size of the fermenter (digester) depends on the input volume of the substrate (feed material for microbial action) in suspension and the HRT. There are other digester configurations which have been discussed later in this chapter. Inside the digester, the feed is diluted to achieve the desired solids content and remains in the digester for a designated retention time. For dilution, a varying range of water sources can be used such as clean water, sewage, or re-circulated liquid from the digester effluent. Usually, the solids concentration is around 6%–10%, but some of the well-known systems have more than 20% total solids; such systems are called dry fermentation or digestion. In batch mode, solids concentration of even 40% can be used.

A heat exchanger can be fitted for better utilisation of heat in the whole system, especially for maintaining the desired temperature range in the digesting vessel.

**Gas Recovery:** The biogas obtained may be scrubbed to ensure automotive quality CNG-like gas ( $\text{CO}_2$  less than 5% and  $\text{H}_2\text{S}$  less than 10 ppm). Biogas may also be used for generating electricity.

**Residue Treatment:** The digested sludge from the digester is dewatered and the liquid recycled for use in the dilution of incoming feed. The biosolids are dewatered to 50%–55% total solids with a screw press, filter press, or other types of dewatering systems and aerobically cured to obtain a compost product.



Segregated organic waste free from inert and toxic material is a pre-requisite for biomethanation

### 3.4.5 OPERATING PARAMETERS FOR BIOMETHANATION

Certain physical parameters should be controlled in the digester to enhance microbial activity and increase efficiency of the system. These parameters include the following:

- **Temperature:** Temperature affects bacterial growth and hence the amount of biogas produced. Treatment of waste in anaerobic reactors is normally carried out within two ranges: around  $25^\circ\text{C}$ – $40^\circ\text{C}$  (ideally  $35^\circ\text{C}$ – $37^\circ\text{C}$ ) known as mesophilic range, and higher than  $45^\circ\text{C}$  (ideally  $55^\circ\text{C}$ – $60^\circ\text{C}$ ) known as thermophilic range.

At higher temperatures (thermophilic range)

- the rate of digestion is faster, and thus shorter retention times are required;
  - smaller reactor volumes are required for treating the same amount of waste;
  - there is higher rate and efficiency of hydrolysis of the suspended particulate matter; and
  - destruction of pathogens is more efficient.
- **pH:** The anaerobic digestion process is limited to a relatively narrow pH band from 6.0 pH to 8.5 pH approximately, especially that the methanogenic bacteria are very sensitive to pH (close to neutral pH around 7.0).
  - **Moisture:** The moisture content of waste is important as explained above.
  - **Toxicity:** A number of compounds are toxic to anaerobic microorganisms. Methanogens are commonly considered to be the most sensitive to toxicity.

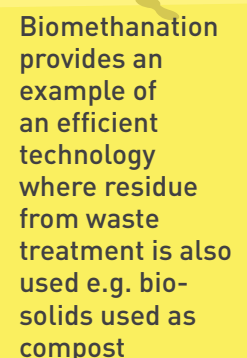

Biomethanation provides an example of an efficient technology where residue from waste treatment is also used e.g. bio-solids used as compost



Anaerobic digestion process can be:

- Single stage: all three stages of anaerobic process occur in one reactor
- Multi stage: acetogenesis and methanogenesis are separated

- **Carbon-to-nitrogen ratio:** Optimum carbon-to-nitrogen (C/N) ratio in anaerobic digesters is 20:30. A high C/N ratio is an indication of rapid consumption of nitrogen by methanogens and results in lower gas production. On the other hand, a lower C/N ratio causes ammonia accumulation and pH values exceeding 8.5, which is toxic to methanogenic bacteria. Optimum C/N ratios of the digester materials can be achieved by mixing material of high and low C/N ratios, such as organic solid waste (high in carbon) and sewage or animal manure (high in nitrogen).
- **Organic loading rate:** Organic loading rate is the frequency and speed at which the substrate is added to the digester. For each plant of a particular size, there is an optimal rate at which the substrate should be loaded. Beyond this optimal rate, further increases in the feeding rate will not lead to a higher rate of gas production. Agitation or consistent stirring of the contents in the digester also plays an important role in determining the amount of biogas produced.
- **Retention time:** The required retention time for completion of the reactions varies with differing technologies, process temperature, and waste composition. The retention time for waste treated in a mesophilic digester ranges from 20 to 30 days. Lower retention times are required in digesters operated in the thermophilic range. A high solids reactor operating in the thermophilic range has a retention time of about 14 days.

### 3.4.6 TYPES OF ANAEROBIC DIGESTERS IN USE

Different types of anaerobic digesters or biogas plants have been designed and used mainly depending upon the following factors:

- iii. monophasic or biphasic number of digesters in the monophasic system;
- iv. floating holder or fixed dome or combination of both;
- v. concentration of substrate (feed material);
- vi. operating temperature—mesophilic (near ambient) or thermophilic (heated digesters maintained around 55°C–60°C);
- vii. batch, semi-continuous or continuous; and
- viii. suspended particulate, upflow anaerobic filter (UAF), upflow anaerobic sludge blanket (UASB), or hybrid systems.

The various systems have their merits and constraints. For example, the fermentation is more efficient or more complete when the concentration of solids is relatively less but the volumetric efficiency of the digester is less.

This means that for unit quantity of substrate, total biogas production is more, but biogas produced per unit volume of the digester is less. On the other hand, when the concentration of the solids is more, gas production per unit volume of the digester is more, but gas production per unit weight of the substrate is less. While designing a digester, one tries to make a balance between these factors. For this reason, the single-stage high solids systems (22%–40% of total solids) are supposed to be more efficient than the single-stage low solids systems (less than 10% total solids).

The predominantly used single-stage low solids reactor is the continuously stirred tank reactor, where the digestate is continuously stirred and completely mixed. Feed is introduced in the reactor at a rate proportional to the rate of effluent removed. Generally, the retention time is 14–28 days depending on the kind of feed and operating temperature.

High solids systems require smaller reactor volumes per unit of biogas production, but high concentrations of solids will result in higher feed pumping costs. Some examples of patented single-stage high solids anaerobic digester systems for solid waste are dry anaerobic composting (DRANCO), Kompogas, and Valorga processes. The retention time in these systems varies from 14 to 20 days.

The DRANCO process is a dry thermophilic process for treatment of the organic fraction of MSW. This process requires high total solids content in the reactor to have optimal performance. After the waste is pre-treated and screened, it is mixed with recirculating material from the reactor. Mixing of the waste with digested material ensures inoculation of the incoming material. The reactor is a downward plug-flow type reactor where mixing is deliberately minimised. The Valorga process could be either a thermophilic or a mesophilic process, where the pre-treated waste is mixed with recycled process water. After mixing with process water, the influent is pumped into the reactor. The reactor is fully mixed reactor type where mixing takes place by pneumatic stirring, i.e., the produced biogas is compressed and sent through the contents of the reactor.

Batch reactors are less efficient and hence not popular for treatment of organic fraction of MSW. Upflow anaerobic sludge blanket (UASB) and upflow anaerobic filter process (UAFP) are typically used for treatment of high strength industrial or municipal waste waters.

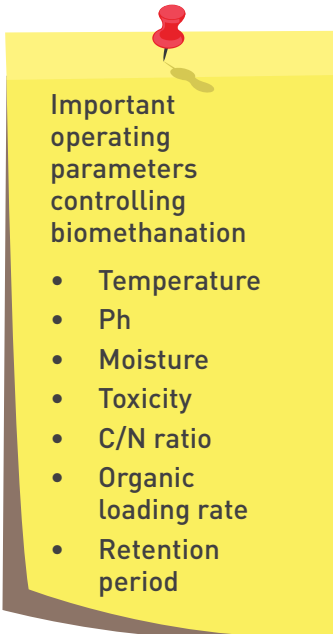

#### Important operating parameters controlling biomethanation

- Temperature
- Ph
- Moisture
- Toxicity
- C/N ratio
- Organic loading rate
- Retention period

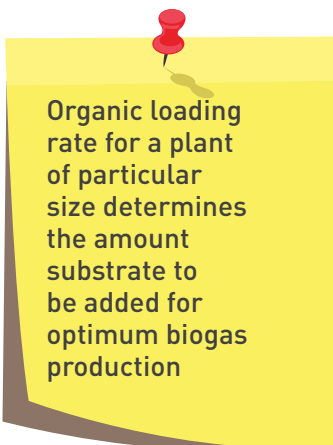

Organic loading rate for a plant of particular size determines the amount substrate to be added for optimum biogas production

Scum formed at the top and layer of heavier fractions at the bottom should be removed on a routine basis to keep biogas yield at optimum levels

Examples of single stage anaerobic digester include: DRANCO (thermophilic), Kompogas and Valorga (mesophilic)



### TERI Enhanced Acidification and Methanation (TEAM) Bioreactor

The Energy and Resources Institute (TERI)'s enhanced acidification and methanation (TEAM) is a patented multi-stage high-rate digester for biomethanation of fibrous and semi-solid organic wastes.

The TEAM process is two-phase. The first phase, regarded as the acidification phase, consists of extracting a high organic strength (chemical oxygen demand of 15,000–20,000 mg/l) liquid called leachate from the solid waste in the acidification reactor. In the second phase, known as the methanation phase, biogas is generated by treating the leachate in an upflow anaerobic sludge blanket (UASB) reactor.

Before the process gets started, the organic solid waste is cut into small pieces and fed into the acidification reactor. The waste bed is kept submerged in water. Organic acids are formed as a result of bed degradation, leading to the formation of leachate. This leachate is periodically recirculated through the bed at a predetermined fixed rate to have uniform concentration of microorganisms and nutrients through the bed and to wash off organic acids formed as a result of further bed degradation.

Once a high chemical oxygen demand (COD) concentration is reached, the leachate is extracted in the leachate collection tank. The acidification phase has a retention time of 6 days; therefore, six such reactors are provided to ensure continuous operation. Anaerobic conditions prevail inside the reactor during the whole process. The phase separation provides suitable environment to the microorganisms in acidification and methanation stages, thus enhancing the activity. The residue inside the acidification reactor is dried in the sun and then used as manure. This system is a variant of the UASB technology for sludge and solid waste treatment.

A waste treatment plant with a capacity of about 50 kg green leafy vegetables per day was installed at TERI's Gual Pahari campus, Gurgaon. The plant has been generating good quality biogas and manure from the organic wastes for a few years. TEAM plant has also been installed in two more places in corporate units like National Thermal Power Corporation (NTPC) India (for household waste management) and Sona Koyo Steering, Haryana (for canteen waste management). This system has good scale-up potential.



### Adoption of the Nisargruna Biogas Technology: An Approach toward Decentralised Waste Management Operated by Waste Pickers

**Location:** Mumbai

**Year of start:** 1998

**Main Players:** Municipal Corporation of Greater Mumbai (MCGM), Stree Mukti Sanghatana (SMS), Bhabha Atomic Research Centre (BARC), waste pickers cooperatives, institutions, Navi Mumbai Municipal Corporation (NMMC)

**Approach:** Mumbai, the capital city of Maharashtra, has witnessed rapid urbanisation, economic growth, and rising standard of living which has led to increase in the quantity of waste generated coupled with inefficient waste management and disposal practices.

The problems are multi-fold and cover issues that relate to the socio-political, economic, and environmental sustainability. Several initiatives have been taken to address these issues like adoption of technology, new management approaches, imposition of regulation, etc. However, all these initiatives remained largely unsatisfactory. In order to address the ever-increasing problems related to waste management, the Advanced Locality Management (ALM) scheme was started in 1997 by MCGM with the main objective of mobilising citizens in a participative approach to set up a system for solid waste management in an environmental friendly manner. Local non-government organisations (NGOs) along with the MCGM have taken up new initiatives through ALM scheme to improve on existing practices, striking the appropriate partnership between MCGM and SMS.

SMS is a woman's liberation organisation established in 1975. SMS has directed its efforts toward uplifting women, primarily by creating awareness in the society about women's issues with the help of songs and theatre, family counselling centres, day care centres, adolescent sensitisation programme, publication of books, etc. About 85% of the waste pickers are women. To uplift this sector, the Parisar Vikas Programme (PVP) was one of the initiatives implemented by SMS in 1998. SMS has imparted training on segregation, handling of waste, composting, and maintaining and operationalising the bio gas plant through interactive sessions with the women waste pickers, who are commonly addressed as "parisar bhaginis" (neighborhood sisters).

#### **Institutional approach:**

- SMS facilitated the formation of federation of self-help groups (SHGs) and cooperatives of several women waste pickers and guided them for signing a formal contract with municipality or individual apartments, institutions, and public and private sector companies.
- SMS trained the waste pickers on the principles of zero waste, segregation concept, pre-sorting and handling waste from multi-family dwellings, operationalising composting and biogas plants.
- A team structure was organised for waste pickers for operating the collection, segregation, and on-site processing unit: one supervisor at one site for every four bhaginis.
- Innovative, locally viable technology for generation of biogas at the site itself (Nisargruna biogas technology) was institutionalised and adopted; and the workers were trained about the operation and maintenance of the plant.
- New training centre for biogas, composting, rain water harvesting, and garbage gallery at Kopar Khairane, Navi Mumbai was developed.
- New training manual for composting and biogas maintenance was developed.

#### **Technological approach:**

- The Nisargruna technology developed by BARC was used to generate biogas and manure. The technology has basically three stages of operation.
- The system is based on a floating dome design, a proven technology for manure digestion in India and China. It is a two-stage continuous wet system. The waste gets hydrolyzed in first stage; and in second stage, methane is produced. The reactor is

constructed underground, reducing the building costs, and the reactor contents flow under gravity by volume displacement.

- Mixing stage. Proper segregation of waste must be done before entering the plant as some material may detrimentally affect the efficiency of the plant. On-site sorting is a prerequisite. Waste is mixed with equal amount of hot water to breakdown fibres, converting it into homogeneous slurry.
- Pre-treatment stage. Slurry is kept in a thermophilic aerobic pre-digester, converting it into organic acids (acetic acid, butyric acid). Every time the digester is fed, an equal amount of reactor content will leave the pre-digester and is fed to the methane reactor.
- Anaerobic digestion stage. Acidic slurry is transferred to an anaerobic tank (methane reactor) to produce methane. Prior digestion helps in improving the purity of methane gas up to 85%, thereby increasing the fuel efficiency.
- Slurry from the methane reactor is then sent to sand pits, and high quality manure is recovered and water is recycled in the plant again, resulting in a zero effluent system.
- Simplified plant operation process was designed to be used by non-skilled workers
- Training for operation and maintenance (O&M) on site was provided to the workers or bhaginis.

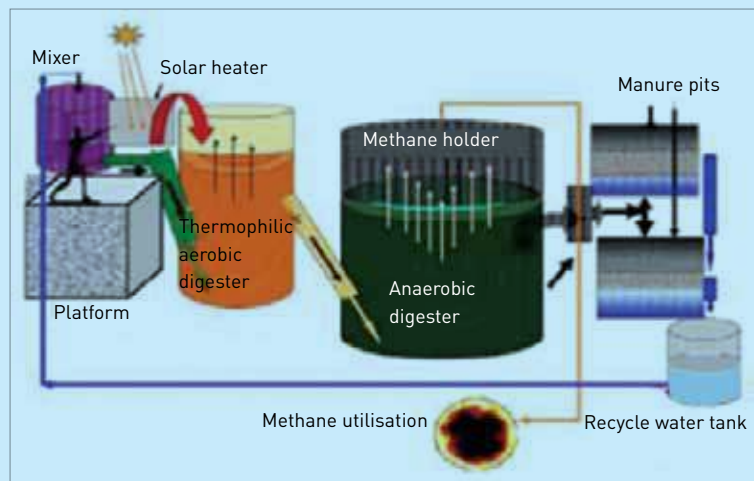

Nisargruna Biogas Plant

**Outcome:**

- 300 groups, with 10 Parisar Bhaginis each, have been established. 200 groups are working as saving groups and a federation of these groups has been registered as an independent organisation called Parisar Bhagini Vikas Sangha (PBVS) along with six working cooperatives.
- 100% segregation of waste was achieved at the plant to produce biogas.
- Recycling efficiency was improved through market exploration and tie-ups with recycling units by SMS.
- There was income from the sale of recyclables (Rs100–Rs150 per day) apart from the service fee for collecting, sorting, and managing biogas plant.
- Only 50 m<sup>2</sup> (less space) was required for a plant processing 100 kg per day.
- Utilisation of the end product as cooking gas fuel for both domestic or industrial purpose.





**Success factors:**

- Strategic partnership is required among SMS, BARC, MCGM, and waste pickers cooperative. Stakeholders should be motivated to take forward the decentralised waste management system.
- On behalf of cooperatives, SMS negotiates, markets, signs, and manages contracts with the apartments and institutions.
- The approach is modular and adaptable to the demands of customer and has simple components.

**Overall sustainability:**

The overall model should have collection, segregation, and on-site processing that is modular and opportunistic, providing services to complement its customers' needs. The simple components and integrated decentralised system has allowed Parisar Vikas to bid for a variety of contracts. The model is self-sustaining and has successfully demonstrated the viability of decentralised waste management as income is generated from the sale of recyclables and at many sites a service fee for collection and managing the biogas plants is charged. The initiative has helped to mainstream the marginalised population of waste pickers giving them a recognised role in the formal waste management system.

*Source: SMS*

**Figure 3.25: Biomethanation Plant for 50 TPD feed (biodegradable MSW and cattle manure)**

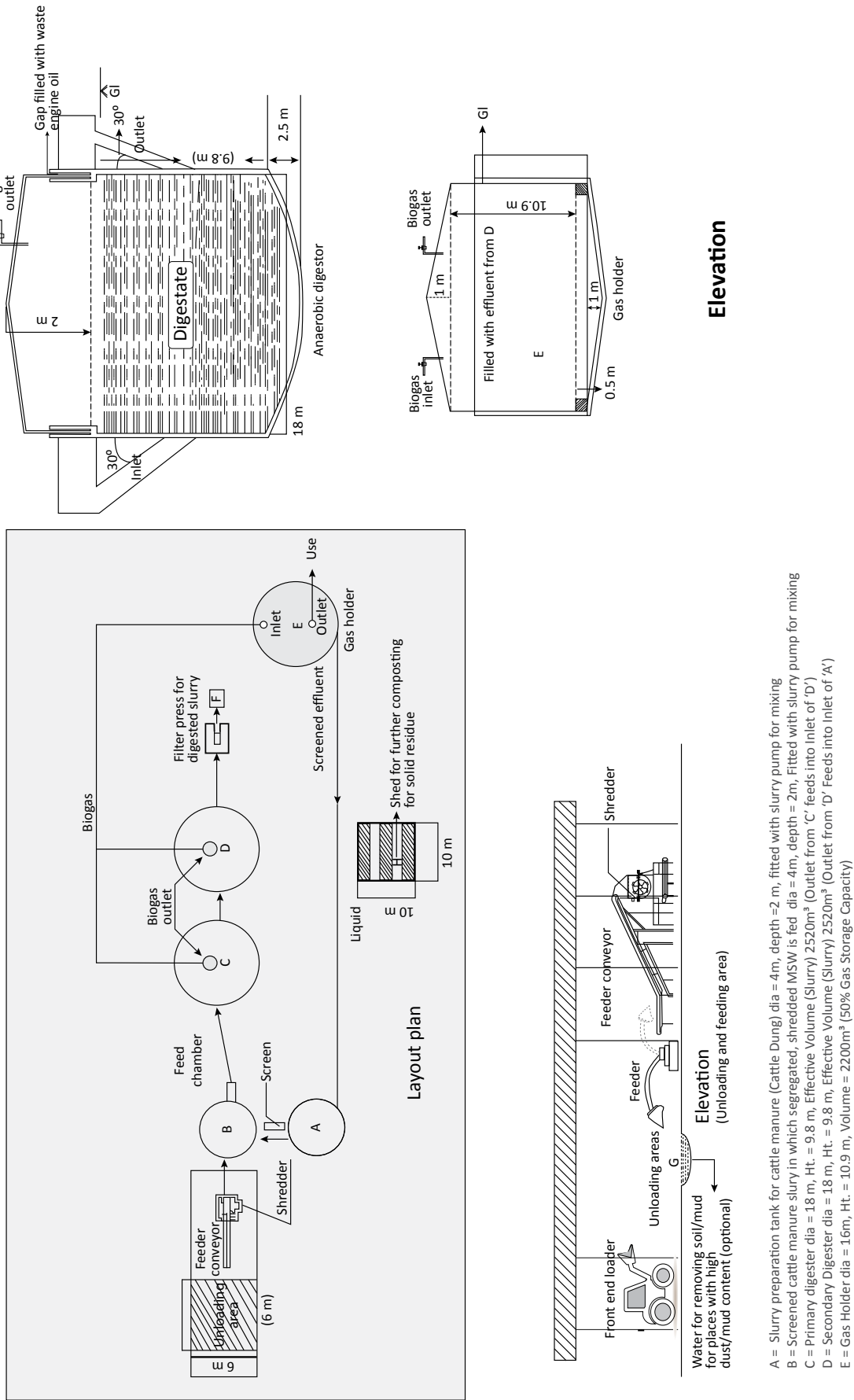

- A = Slurry preparation tank for cattle manure (Cattle Dung) dia = 4m, depth = 2m, fitted with slurry pump for mixing
- B = Screened cattle manure slurry in which segregated, shredded MSW is fed dia = 4m, depth = 2m, Fitted with slurry pump for mixing
- C = Primary digester dia = 18 m, Ht. = 9.8 m, Effective Volume (Slurry) 2520m<sup>3</sup> (Outlet from 'C' feeds into Inlet of 'D')
- D = Secondary Digester dia = 18 m, Ht. = 9.8 m, Effective Volume (Slurry) 2520m<sup>3</sup> (Outlet from 'D' Feeds into Inlet of 'A')
- E = Gas Holder dia = 16m, Ht. = 10.9 m, Volume = 2200m<sup>3</sup> (50% Gas Storage Capacity)
- F = Solid residue from filter press taken to F
- G = Dirty water to be periodically drained into 4m dia, 4m deep pit and supernatant pumped into A/B; bottom sludge to be pumped out and land filled
- H = Shed for Aerobic Windrow Composting / Vermi Composting

**Note:** In Case Cattle Manure is not available 'A' and screen is not required



The plant shown in Figure 3.25 is for a capacity of 50 tonnes per day (TPD). For larger capacities, a series of such digesters (50 TPD capacity or less) can be constructed. In the urban areas, there is accumulation of large quantity of cattle manure in many cities because of the presence of dairy farms within or in periphery of the city. Therefore, two options of the drawings have been presented—one for 50 TPD MSW (biodegradable portion) and the other for combination of the biodegradable MSW and cattle manure (combined weight 50 TPD). In case source segregated waste is not available, pre-sorting or pre-treatment of the waste material will have to be done inside the plant and adequate provision must be planned.

### 3.4.7 UTILITY OF BIOGAS PRODUCED IN BIOMETHANATION PLANTS

The percentage of methane ( $\text{CH}_4$ ) varies with the efficiency of the anaerobic digestion and the composition of the substrate. With cattle manure, about 55%–60% methane is obtained; whereas with water hyacinth and some food waste, 70% methane is obtained. Biogas is also water saturated (100% humidity). The calorific value of biogas is 5,000–6,000 kilocalories per cubic meter ( $\text{kcal/m}^3$ ) depending on the methane percentage. The biogas, by virtue of its high calorific value, has tremendous potential to be used as fuel for power generation through either internal combustion engines or gas turbines.

Broadly, biogas can be used for the following purposes:

- cooking or heating fuel;
- motive power (e.g., biogas pump);
- electrical power; and
- gaseous automotive fuel—after stripping carbon dioxide ( $\text{CO}_2$ ), hydrogen sulfide ( $\text{H}_2\text{S}$ ), and moisture called compressed biogas (CBG).

Since the last couple of years, interest is rapidly growing in CBG.

#### 3.4.7.1 LOCAL GAS USE

The simplest and most cost-effective option for use of biogas is local use with limited pipe length and without stripping  $\text{CO}_2$  and  $\text{H}_2\text{S}$ . Moisture is removed by using a condenser. Typically, such applications are for cooking and mantle lamps. However, in urban areas, there is very limited scope of such application due to presence of liquefied petroleum gas (LPG) cylinders and piped natural gas (PNG). Another option is generation of electrical power, but this can happen only if the volume of gas is sufficient for conversion in a gas engine or a dual fuel engine.



Provision of pre-sorting should be planned at the plant, in case source segregated waste is not received

### 3.4.7.2 PIPELINE INJECTION

Purified and CBG can be injected into PNG line. Certain scale is required for this conversion, especially for the removal of CO<sub>2</sub> and compression to the desired pressure. Practically, this can be done for large biogas plants or battery of biogas plants where the biogas generation is at least 500 m<sup>3</sup> per hour (12,000 m<sup>3</sup> per day).

### 3.4.7.3 ELECTRICITY GENERATION

Electricity can be generated from biogas for on-site processing or for distribution through the local electric power grid. Internal combustion engines and gas turbines are the most commonly used for biogas-to-power generation projects. Unlike automotive use, the CO<sub>2</sub> is not scrubbed, and H<sub>2</sub>S has to be removed to the extent of 50 parts per million (ppm). Although this means lower efficiency, removal of CO<sub>2</sub> requires a certain minimum scale depending on the method of stripping. Their flexibility, especially for small generating capacities, makes them the only electricity generating option for smaller gas volumes.



Under a special purpose vehicle (SPV) - Solapur Bio-Energy Systems Pvt. Ltd (SBESPL), established India's first demonstration plant for MSW processing 400 TPD based on biomethanation (thermophilic anaerobic digester) at Solapur, Maharashtra. The plant is commissioned and in operation since 2013, generating power (4MW) from produced biogas. The electricity generated from the project is being wheeled to the grid for off take by MSEDCL since July 2013 onward.

### 3.4.7.4 PURIFICATION OF BIOGAS

Commercially biogas is purified according to the ultimate use (automotive, electrical power, etc.) by one of the following methods:

- i. cryogenic method;
- ii. high pressure water scrubbing method;
- iii. pressure swing adsorption (PSA) method;
- iv. amine scrubbing method;
- v. metal absorption for H<sub>2</sub>S using iron or copper foil; and
- vi. biological oxidation (biological process for H<sub>2</sub>S).

Each of these has been developed to a commercial level with substantial engineering inputs. However, high pressure water scrubbing, PSA, amine scrubbing, and biological oxidation are in greater use. For selecting the appropriate technology, one has to consider the ultimate use, scale, investment required, space needed, etc.

## 3.5 REFUSE DERIVED FUEL

The SWM Rules, 2016 defines refuse derived fuel (RDF) as fuel derived from combustible waste fraction of solid waste like plastic, wood, pulp or organic waste, other than chlorinated materials, in the form of pellets or fluff produced by drying, shredding, dehydrating and compacting of solid waste. It is used as a fuel for either steam or electricity generation or as alternate fuel in industrial furnaces or boilers (co-processing or co-incineration of waste in cement, lime, and steel industry and for power generation). The composition of RDF is a mixture that has higher concentrations of combustible materials than those in the parent mixed MSW.

### 3.5.1 LEGAL FRAMEWORK FOR REFUSE DERIVED FUEL PRODUCTION AND UTILISATION



As per SWM Rules, 2016:

Clause 15: Duties and responsibilities of local authorities:-

- (v) facilitate construction, operation and maintenance of solid waste processing facilities and associated infrastructure on their own or with private sector participation or through any agency for optimum utilisation of various components of solid waste adopting suitable technology including the following technologies and adhering to the guidelines issued by the Ministry of Urban Development from time to time and standards prescribed by the Central Pollution Control Board. Preference shall be given to decentralised processing to minimize transportation cost and environmental impacts such as-
  - b) waste to energy processes including refused derived fuel for combustible fraction of waste or supply as feedstock to solid waste based power plants or cement kilns;
- 18. Duties of the industrial units located within one hundred km from the refused derived fuel and waste to energy plants based on solid waste- All industrial units using fuel and located within one hundred km from a solid waste based refused derived fuel plant shall make arrangements within six months from the date of notification of these rules to replace at least five percent of their fuel requirement by refused derived fuel so produced.
- 21. Criteria for waste to energy process.-
  - (1) Non recyclable waste having calorific value of 1500 K/cal/kg or more shall not be disposed of on landfills and shall only be utilised for generating energy either or through refuse derived fuel or by giving away as feed stock for preparing refuse derived fuel.
  - (2) High calorific wastes shall be used for co-processing in cement or thermal power plants.

- (3) The local body or an operator of facility or an agency designated by them proposing to set up waste to energy plant of more than five tones per day processing capacity shall submit an application in Form-I to the State Pollution Control Board or Pollution Control Committee, as the case may be, for authorisation.
- (4) The State Pollution Control Board or Pollution Control Committee, on receiving such application for setting up waste to energy facility, shall examine the same and grant permission within sixty days.

Also Schedule II A (d) states that pre-process and post-process rejects shall be removed from the processing facility on regular basis and shall not be allowed to pile at the site. Recyclables shall be routed through appropriate vendors. The non-recyclable high calorific fractions to be segregated and sent to waste to energy or for RDF production, co-processing in cement plants or to thermal power plants. Only rejects from all processes shall be sent for sanitary landfill site(s).

The SWM Rules, 2016 specifies that the “residual combustible wastes shall be utilised for supplying as a feedstock for preparing RDF or for generating energy or power from the waste by adopting proven waste to energy (WtE) technologies for which emission standards as well as standards for dioxins and furans have been prescribed by the Central Pollution Control Board (CPCB).” Currently, there are no binding legal definitions which specify the composition of RDF, conditions of use, or environmental monitoring requirements for RDF incineration.<sup>39</sup>

To put in a nutshell:

- RDF based power projects come under the purview of the Electricity Act, 2003.
- RDF facilities are also governed by the Environment Protection Act. These facilities also have to obtain the consent for establishment and consent for operation licenses from the State Pollution Control Boards (SPCBs).
- Emission standards are specified by the SPCB in accordance with the National Ambient Air Quality Standards, 2009.
- All industrial units utilising RDF as fuel also have to adhere to applicable laws (air, water, and environment protection acts). Stack emissions have to be monitored once a year and submitted to the SPCB.
- Cement kilns using RDF also come under the purview of all the above acts.
- Emissions from industries like cement or power shall be governed by the industrial norms.

In Europe, there is a separate directive for RDF. The Annex IIB of EU Directive 75/442/EEC as amended, defines RDF as waste used “principally as a fuel or other means to generate energy.” This directive specifies the norms and standards for production, utilisation, and monitoring mechanisms to regulate RDF.

<sup>39</sup> GlZ. (n.d.). Status Paper on Utilisation of Refuse Derived Fuel (RDF) in India. [http://www.igep.in/live/hrdpmp/hrdpmaster/igep/content/e54413/e54441/e61172/e61173/20130425\\_RDFstatuspaper\\_final4.pdf](http://www.igep.in/live/hrdpmp/hrdpmaster/igep/content/e54413/e54441/e61172/e61173/20130425_RDFstatuspaper_final4.pdf)

### 3.5.2 REFUSE DERIVED FUEL IN INTEGRATED SOLID WASTE MANAGEMENT HIERARCHY

While according to the integrated solid waste management (ISWM) hierarchy (Figure 3.26) source reduction, reuse, and recycling are the most sustainable solid waste management options, recovery of energy from MSW is the next desirable waste management strategy.

Production and combustion of RDF for energy recovery is not only an economically viable option for municipal solid waste management (MSWM), but it also greatly reduces the requirement for landfill space. The techno-economic feasibility of producing high calorific value RDF from mixed MSW has to be seen in the context of the concrete framework conditions of a particular urban local body (ULB).

The opportunity to produce high calorific value RDF from mixed waste rather than dumping waste makes RDF a more desirable option than landfilling

Figure 3.26: Refuse Derived Fuel in Integrated Solid Waste Management Hierarchy

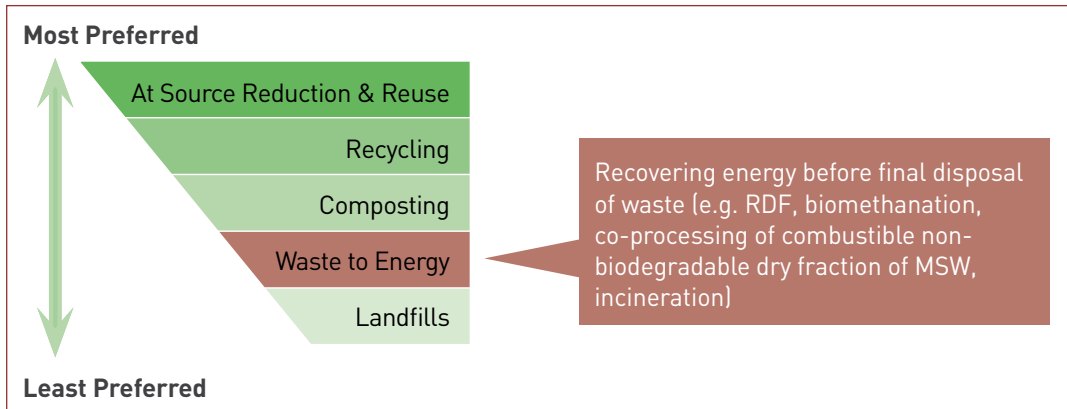

### 3.5.3 GENERAL COMPOSITION OF REFUSE DERIVED FUEL IN INDIA

RDF typically consists of the residual dry combustible fraction of the MSW including paper, textile, rags, leather, rubber, non-recyclable plastic, jute, multilayered packaging and other compound packaging, cellophane, thermocol, melamine, coconut shells, and other high calorific fractions of MSW. However from the ISWM hierarchy perspective, the city should prioritise separately recycling relevant components (e.g., paper, plastics, jute, metal, glass, multilayered packaging used for liquid food items, etc.). The composition and resultant energy content of RDF varies according to the origin of waste material and the sorting, separation, and processing being adopted in the facility.

Typical desired ranges of these parameters observed in various studies are indicated in Table 3.13. Values given herein are specific to the considered waste mix and are only indicative in nature. Required quality of RDF is determined by the end use of the fuel.

RDF typically consists of high calorific fractions of MSW like paper, textile, jute etc.

**Table 3.13: Indicative Net Calorific Value of Refuse Derived Fuel vs. Coal<sup>40</sup>**

| ITEM  | NET CALORIFIC VALUE (KCAL) |
|---|----------------------------|
| Indian coal   | 2500-5000                  |
| Mixed plastic   | 6000                       |
| Segregated municipal solid waste (plastic, cloth, jute, paper, multilayered polythene, multilayered packaging, thermocol, melamine, coconut shells) | 2000-2500                  |

The suitability of RDF for use as a fuel is dependent on certain critical parameters of the constituent waste:

- calorific value;
- water content;
- ash content;
- sulphur content; and
- chlorine content.

The required specific composition and characteristics of RDF for co-processing will be determined by the kind of furnace, temperatures achieved in the furnace, and the associated flue gas management systems.

### 3.5.4 REFUSE DERIVED FUEL POTENTIAL FROM MUNICIPAL SOLID WASTE

RDF quantity and composition is determined by the nature of the waste and extent of materials recovery or recycling processes implemented by the city. The quantity of RDF that can be produced per ton of MSW varies depending on the type of collection, pre-processing, and composition of waste source.

### 3.5.5 UTILISATION OF REFUSE DERIVED FUEL

RDF may be utilised in the following manner:

- co-processing in cement kilns;
- co-combustion in coal fired power plants (however, attempts to do so are under way and has not been proven effective yet in India); and
- on-site or off-site in an appropriately designed waste incinerator for thermal recovery or power generation.

RDF quantity and composition is determined by the nature of the waste and extent of material recovery or recycling processes implemented by the city

<sup>40</sup> Exploring co-processing as an option for disposal of certain fraction of MSW. GIZ (2010).



### 3.5.6 REFUSE DERIVED FUEL PRODUCTION PROCESS

The RDF production line (Figure 3.27) consists of several unit operations in series to separate unwanted components and condition the combustible matter to obtain required RDF characteristics. In general, segregation and processing may include:

- sorting or mechanical separation (in case of effectively source segregated feed material, this process may not be required);
- size reduction (shredding, chipping, and milling);
- drying (where required);
- separation;
- screening;
- air density separation (for removing fine inert material);
- blending;
- packaging; and
- storage

The quality of RDF depends on the characteristics of incoming waste feed. Segregation of waste into combustibles and non-combustibles is a pre-requisite

The type and configuration of unit operations selected depend on the type of secondary material that will be recovered and on the desired quality of the recovered fuel fraction. The end use of the RDF determines the necessary characteristics of RDF (size, moisture, ash content, calorific value, chloride, heavy metals, etc.).

Figure 3.27: Refuse Derived Fuel Production Line (Pelletization)<sup>41</sup>

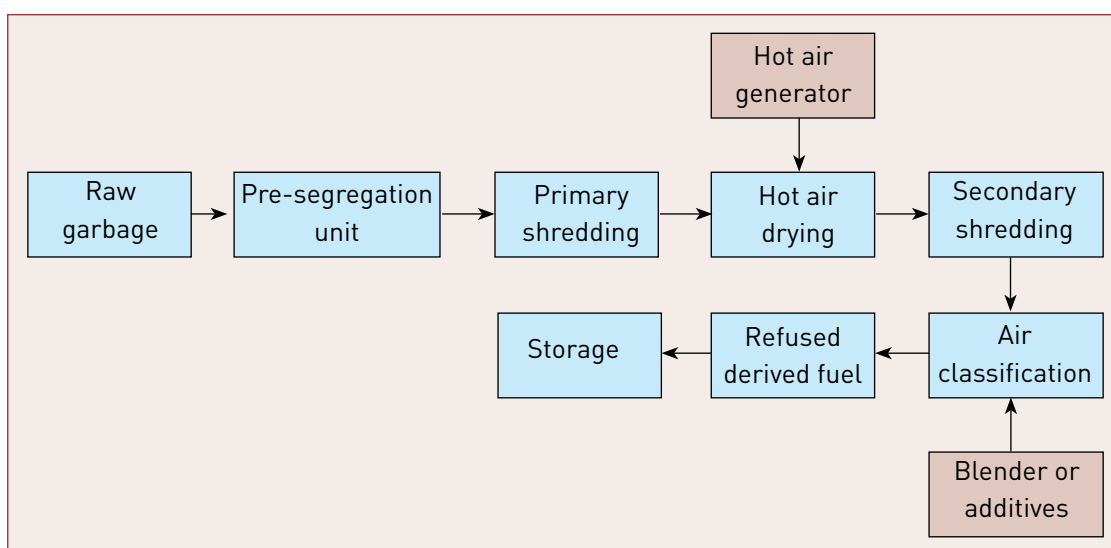

41 International Council for Local Environmental Initiatives South Asia.



### Historical Evolution of RDF Pilot Plants

Bengaluru, 1998

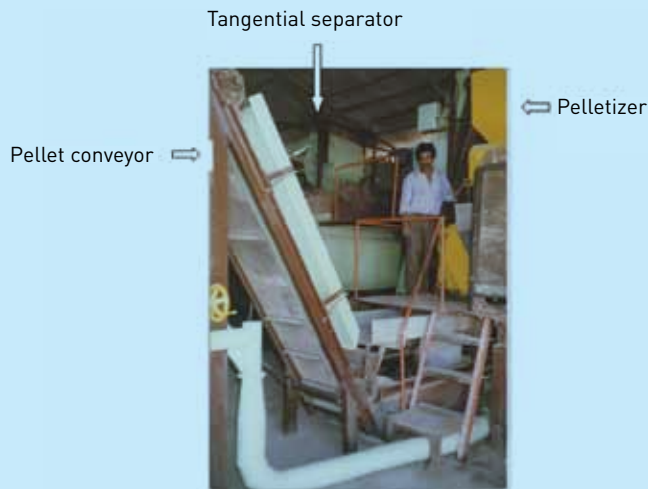

**Pelletization:** In the early days of refuse derived fuel (RDF) production, pelletization of RDF was favoured. The current trend is to use RDF fluff (shredded un-consolidated RDF).

**RDF Pellets:** Light combustibles were ground to 10–15 mm particle size. The binder or additives were mixed with ground garbage in a mixer or conditioner before pelletizing. The pellets coming out of the pelletizer were cooled and stored in the pellet storage yard for dispatch.



Only those plastics that cannot be techno-economically recycled or reused may be considered for co-processing as RDF

### 3.5.7 POTENTIAL USE OF REFUSE DERIVED FUEL IN INDUSTRY

In keeping with the present state of technology, RDF is fired in a moving grate furnace or a boiler equipped with some form of grate. RDF can also serve as a feedstock for other types of thermal systems, e.g., pyrolysis and fluidised bed systems. The relative uniformity of properties and higher quality of RDF as compared with mixed MSW has led, in the past, to a preference for RDF in some applications.



### 3.5.7.1 CO-PROCESSING IN CEMENT KILNS OR COAL BASED POWER PLANTS

RDF can be used in cement plants as a partial substitute for fossil fuels. Any RDF produced in a municipal waste management plant should be used for co-processing only in processes equipped with suitable air pollution abatement technology. Emission standards are to be prescribed by CPCB or relevant SPCB. In India, currently, the only proven sustainable use of RDF is for co-processing in cement plants. Depending on the characteristics of the RDF and the plant design, this RDF can be fed into the kiln or the pre-calciner. It needs to be noted that certain constituents of the RDF, such as chlorine, need to be controlled to avoid adverse impacts on the production processes and end product quality.

The suitability of RDF for use in a cement kiln as a fuel is contingent on the material having the appropriate consistency, heat value, and composition as per the requirements of the specific cement plant.

#### 3.5.7.1.1 Technical Specification of Boilers

Boiler design dictates the final shape and size of RDF. Most boilers designed to burn RDF use spreader stokers and fire fluff RDF in a semi-suspension mode.

It is proven that RDF co-processing in cement kilns has several advantages. The cement kiln process has wide ranging temperature zones with different residence times which provide opportunities to fine tune waste management systems appropriately. Different wastes can be co-processed at different points within the kiln system depending on their physical and chemical characteristics. The temperature in the cement kiln process varies from about 850°C to 1,800°C. Excess level of oxygen and counter flow operation with flue gases moving in a direction opposite to the materials lends a high degree of turbulence to the process. The presence of an alkaline reducing environment (lime) and the pre-heating of the raw materials by a pre-heater tower (>100 m tall) acts as an ideal scrubber for hot flue gases before they are emitted into the atmosphere. The long residence time, temperature, and turbulence in cement kilns provides extremely high destruction removal efficiency for all waste types (>99.99%). Co-processing leaves no residue as the incombustible, inorganic content of the waste materials are incorporated in the clinker matrix.



Long residence time, high temperature and turbulence in cement kilns ensures minimal production of dioxins and furans



### Desirable Refuse Derived Fuel Characteristics for Co-processing in Cement Plants (Pre-calciner/Kiln)<sup>49</sup>

- Moisture, preferably < 20%
- Size, 2D < 120 mm, 3D < 70 mm subject to process limitation of specific cement plant
- Chlorine, preferably < 0.7% depending on particular raw mix and fuel mix
- Calorific value, preferably > 3,000 kcal/kg
- Sulfur, < 2% depending on particular raw mix and fuel mix
- Free of restricted items (polyvinyl chloride, explosives, batteries, aerosol containers, biomedical waste)

Siting of RDF plant plays an important role in ensuring viability of RDF usage in cement plants. Ideally, distance between RDF and cement plants should be within 200 km radius

#### Advantages of co-processing RDF in cement kilns:

- High kiln temperature (1,800°C at main burner and 1,000°C at pre-calciner) ensures destruction of organic pollutants.
- Long residence time (5–6 seconds at 1,800°C and 2–6 seconds at > 800°C) yields complete combustion.
- Self-cleaning process of acid gas is done by lime.
- Ash is incorporated into the clinker matrix

#### Limitations of co-processing RDF in cement kilns:

- More often than not, cement industry enterprises are reluctant to use RDF because of lack of established practice and requirements of retro-fitting of the existing feeder mechanisms.
- Regular supply of adequate quantity and quality of RDF is not available.
- Economics of producing and marketing RDF are largely contingent on the distance to which the finished RDF needs to be hauled by the ULB. Economic viability of the RDF system can be ensured by supplying appropriate quality of RDF to cement plants within a 200 km radius from the RDF production plant.

In order to overcome some of these shortcomings, the RDF processing facility may produce crude RDF. This RDF from multiple locations can be transported to the cement plant by either the ULB or operator or cement plant. Further refinement of the RDF may be accomplished at the cement plant through installation of secondary shredders, hot air generators, and air density separator, based on the specific requirements.





### Benefits of Refuse Derived Fuel Based Plants Vs. Mass Burn Plants

- Refuse-derived fuel (RDF) is a buffer against fluctuating quality of incoming waste, since the waste is segregated and processed to ensure that the RDF comprises only desired waste fractions.
- All boilers (incinerators), including those using RDF as fuel, require an annual shutdown for 4–6 weeks for mandatory maintenance. During such time, the produced RDF may be sent for co-processing in cement plants or power plants. However, in mass burn plants, during periods of shutdown, the mixed waste will need to be diverted.



### Co-processing of Segregated Plastic Waste: An Initiative of Jabalpur Municipal Corporation and ACC–Holcim

**Location:** Jabalpur, ACC–Kymore Cement Works

**Main Players:** Jabalpur Municipal Corporation (JMC), ACC–Kymore Cement Works, Central Pollution Control Board (CPCB), Madhya Pradesh Pollution Control Board (MPPCB), waste pickers

**Year of start:** 2008

**Approach:** A committee was constituted by the High Court of Delhi under the chairmanship of Justice R. C. Chopra to study the issue of environmental hazards, including health hazards from the use of plastic bags and waste generation. One of the recommendations submitted by the committee was to use plastic waste as a partial fuel in the cement kilns. The matter was further discussed in 54<sup>th</sup> Conference of Chairman and Member Secretaries of State Pollution Control Board (SPCBs). These discussions in the APEX conference prompted MPPCB to identify rotary cement kilns for co-processing of non-recyclable plastic waste and to tie up with municipal corporations. Kymore Cement Works of ACC Limited<sup>43</sup> pioneered the initiative, and the trial of segregated plastic waste was conducted successfully. The approach adopted includes:

1. planning and formulation of the strategy for the disposal of plastic waste by identifying different stakeholders and linkages in the process;
2. assessment of plastic waste generation in the municipal corporation;
3. coordination with cement industries by MPPCB for conducting trial runs for co-processing of plastic waste;
4. establishment of the system managed solely by waste pickers, sub-vendors, and kabadi system;
5. ensuring the arrangements for the transportation of the plastic waste to the cement plant;
6. development of appropriate storage and handling facility at ACC–Kymore; and
7. regular skill development and awareness programmes for the waste pickers.

<sup>43</sup> ACC is a 77-year-old cement company in India. It is now under Holcim, a Swiss-based global cement company which is a pioneering cement company providing cement kiln co-processing solutions for management of wastes.

### **Outcome**

1. Out of 340 tonnes of MSW generated in Jabalpur Municipal limits, 5% was plastic and other combustible fractions (approximately 15–20 tonnes of waste per day), which was sent to the cement plant.
2. JMC introduced door-to-door waste collection service from households in 6–7 colonies as a pilot service wherein waste pickers collect the waste.
3. Self-help groups (SHGs) of over 200 waste pickers were formed for collection and segregation of waste.
4. JMC initiated a process of issuing identification numbers followed by issuing identification cards to the waste collectors or waste pickers to formally integrate them into the system.
5. Non-recyclable fractions of waste—e.g., double coated plastic, torn paper, jute, tetrapaks, thermocol, waste tyres, etc.—were segregated and transported to cement plants.
6. Until 2013, ACC–Kymore Cement Works had successfully co-processed 1,622 tonnes of segregated waste, and the initiative is being replicated in other locations as well.

### **Success Factor**

- Proactive role of CPCB, MPPCB, and JMC
- Regular capacity building of workers
- Readiness of the cement plants to modify the equipment according to the feedstock

### **Overall sustainability**

To demonstrate the co-processing methodology, ACC had conducted co-processing trial of plastic waste at Kymore Cement Works plant, with support from CPCB and MPPCB. The results of the trial run demonstrated that there are no negative influences of the stack emissions on product quality. The presence of high temperature and long residence time of the kiln ensures complete destruction, thus making co-processing in cement kiln a safer and greener way of management of segregated plastic waste. The pilot was replicated in Bhopal and Indore in Madhya Pradesh and gradually spread in many states, e.g., Tamil Nadu, Orissa, etc., wherever the SPCB and cement industry took an active role in the subject.

Considering the importance and benefits of the co-processing technology and based on the experience of various successful trial runs for hazardous and non-hazardous waste across the country, CPCB formulated the “Guidelines on Co-processing in Cement or Power or Steel Industry.” In these guidelines, CPCB has included plastic as a non-hazardous fraction that can be co-processed.

However, co-processing of plastic fraction as a substitute to coal is still in its nascent stage, and the business model is yet to be fully developed.

*Source: ACC-Holcim*

### 3.5.8 MONITORING REQUIREMENTS FOR FACILITIES UTILISING REFUSE DERIVED FUEL

The SWM Rules, 2016 is the only legal document stipulating standards for flue gas emissions from incineration. However, standards for emissions from boilers using RDF are not specifically stated. Therefore, until such standards are specified, stack emission standards for treatment or utilisation of MSW using incinerators and thermal technologies, as provided in Clause C of SWM Rules, 2016, should be adhered to.

### 3.5.9 GREENHOUSE GAS MITIGATION POTENTIAL FROM REFUSE DERIVED FUEL UTILISATION

Waste management practices can influence greenhouse gas (GHG) emissions by affecting energy consumption, methane generation, carbon sequestration, and non-energy-related manufacturing emissions.

There are a number of climate-related advantages of converting MSW into fuel for power generation. These include reducing the methane emission from landfills that would have been generated from anaerobic degradation of the organic components. The production and subsequent utilisation of the RDF as fuel for energy recovery processes is a better option than mass burn. Uncontrolled combustion of materials such as plastic waste increase the atmospheric concentration of GHGs. RDF also reduces the consumption of depleting resources such as fossil fuels.



SPCB or CPCB set environmental standards for emissions from RDF combustion

## 3.6 TECHNOLOGIES UNDER DEVELOPMENT

Prevalent MSW treatment and processing technologies are based on long-lasting experiences in many countries. However, there are upcoming technologies which have been successfully tested in laboratories and in pilot facilities, but remain to be validated commercially. With respect to the applicability of upcoming technologies, some of these are being tested with support from the Government of India. The results of these tests should be awaited.

As indicated in the Report of the Task Force on Waste to Energy by the Planning Commission, pyrolysis and gasification are some of the technologies that could be explored by ULBs beside incineration, biomethanation, and RDF. However, the economics of these technologies is sensitive to waste characteristics and quantities. Until these technologies are well established commercially, these should be regarded as experimental technologies and should be handled as a research and development (R&D) project or specially designed concession agreements through public-private partnership (PPP) mode in case of large plants. Five years of successful commercial operation of new technologies may be regarded as a safe bet. Pilot projects based

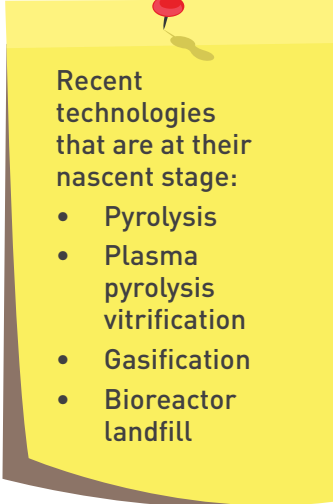

Recent technologies that are at their nascent stage:

- Pyrolysis
- Plasma pyrolysis vitrification
- Gasification
- Bioreactor landfill

on new technologies could be encouraged through private funding or a combination of government and private funding. However, replication of technologies in other cities should be allowed only after successful implementation of the pilot project or when 100% capital cost is borne by private entrepreneur and government provides generation based support.



#### Factors for consideration while adopting Alternative Technologies for Municipal Solid Waste Processing

- Established technologies for defined and clean substances don't work automatically for heterogeneous wastes.
- Alternative technologies have to cope with:
  - existing stringent emission standards;
  - reliable continuous operation;
  - verification of a complete analysis of inputs and outputs; and
  - proof of reliable costs (investment, operation, maintenance).
- Decisions to rely on alternative technologies need backup by other possibilities to dispose waste in case the new technology system fails.
- If a solution for managing the arising waste is needed urgently, proven technologies are recommended.

This section details a few selected technologies, namely, pyrolysis and gasification.

### 3.6.1 PYROLYSIS

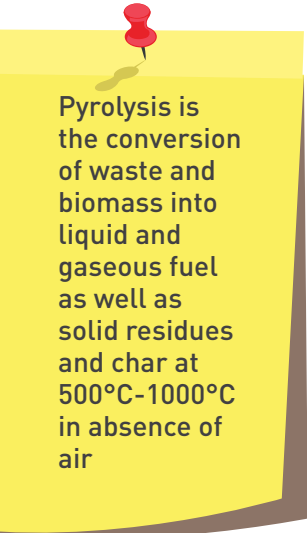

Pyrolysis is the conversion of waste and biomass into liquid and gaseous fuel as well as solid residues and char at 500°C-1000°C in absence of air

Pyrolysis involves an irreversible chemical change brought about by the action of heat in an atmosphere devoid of oxygen. Synonymous terms are thermal decomposition, destructive distillation, and carbonisation. Pyrolysis, unlike incineration, is an endothermic reaction and heat must be applied to waste to distil volatile components. Process of converting plastic to fuels through pyrolysis is possible, but it is yet to be proven to be a commercially viable venture.

Pyrolysis is carried out at 500°C–1,000°C and produces three component streams:

1. **Gas:** It is a mixture of combustible gases such as hydrogen, carbon monoxide, methane, carbon dioxide, and some hydrocarbons.
2. **Liquid:** It consists of tar, pitch, light oil, and low boiling organic chemicals like acetic acid, acetone, methanol, etc.
3. **Char:** It consists of elemental carbon along with the inert material in the waste feed.

Gas, liquid, char are useful because of their high calorific value. Part of the heat obtained by combustion of either char or gas is often used as



process heat for the endothermic pyrolysis reaction. It has been observed that even after utilising the heat necessary for pyrolysis, extra heat still remains which can be commercially exploited.

Although a number of laboratory and pilot investigations have been made, only a few have led to full scale plants. German experience also indicates that while several small scale pyrolysis and gasification plants for MSW were set up a few decades ago, almost all have been shut down due to operational and commercial issues.<sup>44</sup>

### 3.6.1.1 FEED STOCK FOR PYROLYSIS

Feedstock for pyrolysis should have high calorific value with very less moisture content and should be homogenous in nature. Many plastics, particularly the polyolefins, which have high calorific values and simple chemical constitutions of primarily carbon and hydrogen, are usually used as a feedstock in pyrolysis. More recently, pyrolysis plants are being tested to degrade carbon-rich organic material such as MSW. For mixed MSW pre-processing is necessary to bring homogeneity to increase efficiency.

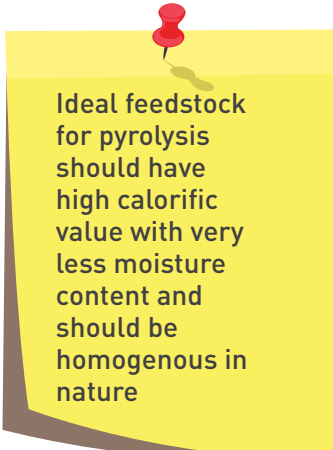

Ideal feedstock for pyrolysis should have high calorific value with very less moisture content and should be homogenous in nature

### 3.6.1.2 MUNICIPAL SOLID WASTE PYROLYSIS

Sorted and pre-treated feedstock is supplied to pyrolysis reactor—rotary kilns, rotary hearth furnaces, and fluidised bed furnaces are commonly used as MSW pyrolysis reactors—where partial combustion of material occurs at 500°C–800°C.

As a result of combustion of organic matter in an oxygen-deficient environment, various products such as char (ash), pyrolysis oil, and syngas are produced. Production of these is dependent on the organic component of MSW, temperature, pressure, and time of retention in the reactor. Char or solid residue is a combination of non-combustible material and carbon. Figure 3.28 shows an overview of the pyrolysis process.

The syngas is a mixture of gases (combustible constituents include carbon monoxide, hydrogen, methane, and a broad range of other volatile organic compounds). Syngas is further refined to remove particulates, hydrocarbons, and soluble matter, and is then combusted to generate electricity. The syngas typically has a net calorific value (NCV) of 2,800–4,800 kilocalorie per normal cubic meter (kcal/Nm<sup>3</sup>) or 10–20 megajoule per normal cubic meter (MJ/Nm<sup>3</sup>). If required, the condensable fraction can be collected by cooling the syngas, potentially for use as a liquid fuel (oils, waxes, and tars).

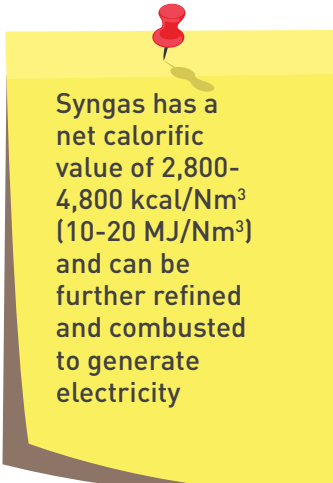

Syngas has a net calorific value of 2,800-4,800 kcal/Nm<sup>3</sup> (10-20 MJ/Nm<sup>3</sup>) and can be further refined and combusted to generate electricity

44 Evolution of Waste Incineration and Co-Processing - In Germany and Europe - Dr.-Ing. Helmut Schnurer Deputy Director General (retired) - Federal Ministry for the Environment Bonn and Berlin, Germany, Presented at the 2nd Expert Committee Meeting for the Revision of the CPHEEO Municipal Solid Waste Management Manual

One key issue for use of syngas in energy recovery is tarring. The deposition of tars can cause blockages and other operational challenges and has been associated with plant failures and inefficiencies at some pilot and commercial scale facilities. Tarring issues may be overcome by higher temperature secondary processing.

In order to recover the energy content of syngas, it should be further processed in the following ways:

1. Syngas can be burned in a boiler to generate steam, which may be used for power generation or industrial heating;
2. Syngas can be used as a fuel in a dedicated gas engine;
3. Syngas, after reforming, may be suitable for use in a gas turbine;
4. Syngas can also be used as a chemical feedstock.

**Figure 3.28: Municipal Solid Waste Pyrolysis** <sup>45</sup>

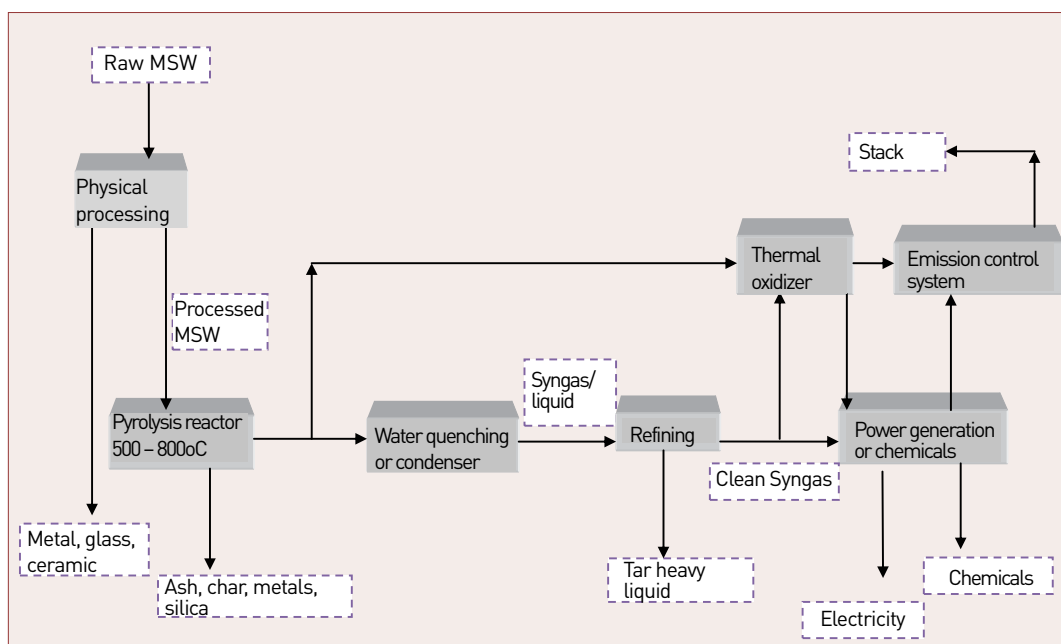

For plasma pyrolysis of MSW, it should be noted that—along with pre-sorted MSW as feedstock—additional inputs, such as flux material and carbonaceous material (e.g., coke) are required.

The first pyrolysis plant that uses MSW exclusively as feedstock is under construction in Tees Valley in the United Kingdom. The plant is to process 950 tonnes per day (TPD) of household waste and converts it into 50 megawatts (MW) of electricity.

For hazardous waste, a plasma pyrolysis facility has been set up in Talaja, near Mumbai.

<sup>45</sup> Developed by the Expert Committee for revision of MSWM manual (2013-15).



### 3.6.1.3 PLASMA PYROLYSIS VITRIFICATION

This is a modified pyrolysis technology aiming at energy or resource recovery from organic waste. The system uses a plasma reactor, which generates, by application of high voltage between two electrodes, an extremely high temperature (5,000°C–14,000°C). This hot plasma zone dissociates the molecules in any organic material into the individual elemental atoms, while all the inorganic material are simultaneously melted into a molten lava. This process is still far away from any proven practical and sustainable application in MSWM.

Plasma pyrolysis vitrification is a modified pyrolysis technology which employs application of high voltage to decompose inorganic matter in waste stream

### 3.6.2 GASIFICATION

Gasification is a partial combustion of organic or fossil based carbonaceous material, plastics, etc. into carbon monoxide, hydrogen, carbon dioxide, and methane. This is achieved at high temperature (650°C and above), with a controlled amount of air, oxygen, or steam. The process is largely exothermic, but some heat may be required to initialise and sustain the gasification process. The main product is syngas, which contains carbon monoxide, hydrogen, and methane. Typically, the gas generated from gasification will have an NCV of 4–10 MJ/Nm<sup>3</sup>. The other main product produced by gasification is a solid residue of non-combustible material (ash), which contains a relatively low level of carbon.

Gasification is a process of converting carbonaceous material in MSW into CO<sub>2</sub> and syngas (CO, H<sub>2</sub> and CH<sub>4</sub>) at high temperatures in the presence of controlled air or steam

#### 3.6.2.1 GASIFICATION OF MUNICIPAL SOLID WASTE<sup>46</sup>

**Feedstock Preparation:** MSW should be pre-processed before it can be used as feedstock for the gasification process. The pre-processing comprises of manual and mechanical sorting, grinding, blending with other material, drying, and pelletization. The purpose of pre-processing is to produce a feed material with consistent physical characteristics and chemical properties. Carbonaceous material of municipal waste stream is most important feedstock for gasification.

Gasification of MSW in the waste gasification plant as shown in Figure 3.29 is accomplished in two chambers: (i) the primary chamber is operated below the stoichiometric air requirement and (ii) the secondary chamber is operated under excess air conditions. The waste is fed into the primary chamber and semi-pyrolyzed, releasing moisture and volatile components. The heat is provided by the controlled combustion of fixed carbon within the waste. The syngas that is driven off contains a high calorific value and can act as a feedstock for the secondary chamber. Combustion air is then added to the syngas, making it highly combustible and prone to self-ignition. The secondary chamber is equipped with

Gasification takes place in two chambers:

- Primary chamber: operated below stoichiometric air requirement
- Second chamber: under excess air conditions

46 "Gasification of Municipal Solid Waste". Zafar, S. (2009). Altenergymag. [http://www.altenergymag.com/content.php?issue\\_number=09.06.01&article=zafar](http://www.altenergymag.com/content.php?issue_number=09.06.01&article=zafar)

a conventional burner to maintain operating temperature at all times. The combined gases are combusted in the secondary chamber.

Figure 3.29: Waste gasification plant<sup>47</sup>

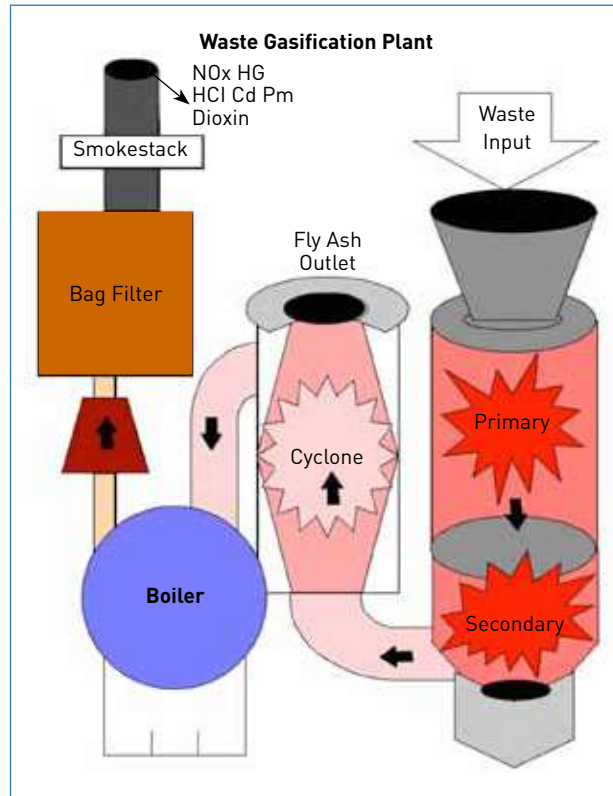

### 3.6.2.2 TYPES OF GASIFIERS FOR MUNICIPAL SOLID WASTE TREATMENT

Gasification technology is selected on the basis of available fuel quality, capacity range, and gas quality conditions. The main reactors used for gasification of MSW are fixed beds and fluidised beds. Larger capacity gasifiers are preferable for treatment of MSW because they allow for variable fuel feed, uniform process temperatures due to highly turbulent flow through the bed, good interaction between gases and solids, and high levels of carbon conversion.

#### (1) Fixed Beds

Fixed bed gasifiers typically have a grate to support the feed material and maintain a stationary reaction zone. They are relatively easy to design and operate, and are therefore useful for small and medium scale power and thermal energy uses. The two primary types of fixed bed gasifiers are updraft and downdraft.

47 Ibid.

Two main reactors used for gasification are: fixed bed and fluidised bed. Technology selection depends upon available fuel quality, capacity and gas quality

Fixed bed gasifiers are relatively easier to design and operate and more useful for small and medium scale power and thermal energy uses



In an updraft gasifier, the fuel is also fed at the top of the gasifier but the airflow is in the upward direction. As the fuel flows downward through the vessel, it dries, pyrolyzes, gasifies, and combusts. The main use of updraft gasifiers has been with direct use of the gas in a closely coupled boiler or furnace. Because the gas leaves this gasifier at relatively low temperatures, the process has a high thermal efficiency and, as a result, wet MSW containing 50% moisture can be gasified without any pre-drying of the waste.

In a downdraft gasifier, air is introduced into a downward flowing packed bed or solid fuel stream and gas is drawn off at the bottom. The air or oxygen and fuel enter the reaction zone from the top, decomposing the combustion gases and burning most of the tars. Downdraft gasifiers are not ideal for waste treatment because they typically require a low ash fuel such as wood to avoid clogging.

## (2) Fluidised Beds

Fluidised beds are an attractive proposition for the gasification of MSW.<sup>48</sup> In a fluidised bed boiler, a stream of gas (typically air or steam) is passed upward through a bed of solid fuel and material (such as coarse sand or limestone). The gas acts as the fluidising medium and also provides the oxidant for combustion and tar cracking. Waste is introduced either on top of the bed through a feed chute or into the bed through an auger. Fluidised beds have the advantage of extremely good mixing and high heat transfer, resulting in very uniform bed conditions and efficient reactions. Fluidised bed technology is more suitable for generators with capacities greater than 10 MW because it can be used with different fuels, requires relatively compact combustion chambers, and allows for good operational control. The two main types of fluidised beds for power generation are bubbling and circulating fluidised beds.

In a bubbling fluidised bed (BFB), the gas velocity must be high enough so that the solid particles, comprising the bed material, are lifted, thus expanding the bed and causing it to bubble like liquid. A bubbling fluidised bed reactor typically has a cylindrical or rectangular chamber designed so that contact between the gas and solids facilitates drying and size reduction (attrition). As waste is introduced into the bed, most of the organics vaporise pyrolytically and are partially combusted in the bed. Typical desired operating temperatures range from 900°C to 1,000°C.

A circulating fluidised bed (CFB) is differentiated from a bubbling fluid bed in that there is no distinct separation between the dense solids zone and the dilute solids zone. The capacity to process different feedstock

Fixed bed gasifiers are of two types:

- Updraft: highly efficient, wet waste with 50% moisture can be gasified
- Downdraft: not preferred for MSW treatment

Fluidised bed are preferred for gasification of MSW as it can be used with multiple fuels, offers relatively compact combustion chambers and good operational control

Two types of fluidised bed are:

- Bubbling fluidised bed
- Circulating fluidised bed

48 "Gasification of Municipal Solid Waste". Zafar, S (2009). *Altenergymag*.  
[http://www.altenergymag.com/content.php?issue\\_number=09.06.01&article=zafar](http://www.altenergymag.com/content.php?issue_number=09.06.01&article=zafar)

with varying compositions and moisture contents is a major advantage in such systems.

**Table 3.14: Thermal Capacity of Different Gasifier Design<sup>49</sup>**

| GASIFIER DESIGN           | FUEL CAPACITY  |
|---------------------------|----------------|
| Down draft                | 1kW – 1MW      |
| Updraft                   | 1.1 MW – 12 MW |
| Bubbling fluidised bed    | 1 MW – 50 MW   |
| Circulating fluidised bed | 10 MW – 200 MW |

### 3.6.2.3 EMERGING TRENDS IN GASIFICATION

#### (a) Plasma Gasification

Plasma gasification or plasma discharge uses extremely high temperatures in an oxygen-starved environment to completely decompose input waste material into very simple molecules in a process similar to pyrolysis. The heat source is a plasma discharge torch, a device that produces a very high temperature plasma gas. Plasma gasification has two variants, depending on whether the plasma torch is within the main waste conversion reactor or external to it. It is carried out under oxygen-starved conditions and the main products are vitrified slag, syngas, and molten metal. Vitrified slag may be used as an aggregate in construction; the syngas may be used in energy recovery systems or as a chemical feedstock; and the molten metal may have a commercial value depending on quality and market availability.<sup>50</sup>



#### **Technical and Commercial Challenges of Plasma Gasification Technology for Municipal Solid Waste: A Case of the Eco-Valley Facility in Japan**

The first waste-to-energy (WTE) facilities in the world to utilise plasma gasification technology on a commercial basis is the Eco-Valley facility in Japan which was set up in April 2003. The facility processes up to 220 tonnes per day (TPD) of municipal solid waste (MSW) or up to 165 TPD of a 50/50 mixture of MSW and automotive shredder residue (ASR). The Eco-Valley facility faced several operational issues during the initial 7 years, which were later resolved. Due to poor commercial performance, the plant was closed. Being a first of its kind, Eco-Valley facility had to overcome several operational challenges during and after commissioning:

- 1) The internal diameter of the bottom of the gasifier was initially too large. Cold spots formed which rendered the gasifier inoperable.
- 2) The refractory that was initially specified for the gasifier did not achieve an acceptable lifespan.

<sup>49</sup> Ibid.

<sup>50</sup> Ibid.



- (3) Fine particulate entrained in the syngas that exits the gasifier attacked the refractory in the afterburner and accumulated on the walls of the afterburner.

The plant produced electricity through steam (Rankine cycle). The process employed includes the following:

- 1) Waste Pit: MSW and ASR are deposited in the waste pit. An overhead crane grabs waste and drops it into a shredder to reduce the size of the feedstock to 2.5 inches. The shredded material is returned to the waste pit where it is mixed with ASR, which arrives in shredded form.

- (2) Gasifier: Waste material is conveyed to the gasifier and enters at the top of the vessel. Organic material in the waste was converted into synthesis gas, i.e., syngas, which consists primarily of carbon monoxide, hydrogen, methane combustible gases as well as carbon dioxide and nitrogen non-combustible gases. The syngas exits at the top of the gasifier. Inorganic material were melted and exits the gasifier at the bottom of the gasifier as a molten slag, which forms vitreous granules as it is water quenched.

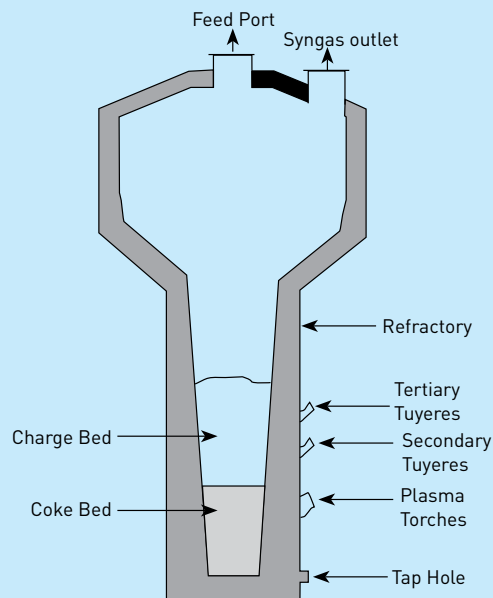

**Schematic Plasma Gasification Reactor used in the Eco valley plant**

- (3) The syngas travels to the afterburner, a refractory lined cylindrical vessel, in which it is immediately combusted.
- (4) The hot gas leaves the afterburner and travels to the heat recovery steam boiler where it was cooled to produce steam.
- (5) The steam was used to drive a steam turbine generator.
- (6) The flue gas exits the heat recovery steam boiler and was cleaned in a bag house system before being vented to the atmosphere.

Such systems are not only very expensive but require a high level of understanding of the nature of the feedstock, may require feedstock other than MSW for commercial viability, and require experienced and advanced technical capacity to ensure smooth and continuous operation. As such, this and similar technologies are not yet proven in the Indian context.

### **3.6.2.4 INTEGRATED GASIFICATION WITH POWER GENERATING EQUIPMENT**

MSW gasification can be integrated with power turbines, steam cycle, and other power generating equipment to provide thermal energy. Combination of MSW gasification with power turbines and fuel cells increases overall efficiency of the system. Development is happening on the following lines:

1. Integrated gasification combined cycle (IGCC) is based on the concept of integrating MSW gasification with gas turbines and steam cycle.
2. Fuel cells are integrated with MSW gasifier. Tubular solid oxide fuel cells have been found to be most effective for these applications.

### **3.6.2.5 CHALLENGES OF OPERATING GASIFICATION PLANTS**

Gasification takes place in low oxygen environment that limits the emission of pollutants. It also generates fuel gas that can be further used in a number of ways, as suggested in the section on pyrolysis. During gasification, tars, heavy metals, halogens, and alkaline compounds are released within the product gas and can cause environmental and operational problems. Tars are high molecular weight organic gases that ruin reforming catalysts, sulfur removal systems, and ceramic filters and increase the occurrence of slagging in boilers, on other metal and refractory surfaces. Alkalis can increase agglomeration in fluidised beds that are used in some gasification systems and can also ruin gas turbines during combustion. Heavy metals are toxic and accumulate, if released into the environment. Halogens are corrosive and a cause of acid rain, if emitted to the environment. The key to achieving cost efficient, clean energy recovery from MSW gasification will be overcoming problems associated with the release and formation of these contaminants.

### **3.6.2.6 CHALLENGES OF UTILISING PYROLYSIS AND GASIFICATION IN THE INDIAN CONTEXT**

- High calorific value waste, which may otherwise be processed in more sustainable processes, is required as feedstock. Organics can be converted into compost in a much more cost-effective and environmentally safe process, as against using them as feedstock for these processes.
- Pyrolysis and gasification processes require specific feedstock quality, which has a direct impact on the efficiency and commercial viability of the product. Pre-treatment of waste is a must. Specific size and consistency of solid waste should be achieved before MSW can be used as feed.



## 3.7 CONSTRUCTION AND DEMOLITION WASTE (C&D WASTE)

With the growing importance of construction and demolition waste, the Government of India has deemed it appropriate to formulate a separate regulation for construction and demolition waste namely Construction and Demolition Waste Rules, 2016 describing the roles and responsibilities of the different stakeholders as well as the compliance criteria for the management of the construction and demolition waste.

According to the rules, construction and demolition waste “means the waste comprising of building materials, debris and rubble resulting from construction, remodeling, repair and demolition of any civil structure.

C&D waste includes bricks, tiles, stone, soil, rubble, plaster, drywall or gypsum board, wood, plumbing fixtures, non-hazardous insulating material, plastics, wall paper, glass, metal (e.g., steel, aluminium), asphalt, etc. However, C&D waste does not include any hazardous waste as defined under the Hazardous and Other Wastes (Management and Transboundary Movement) Rules, 2016.

### 3.7.1 SOLID WASTE MANAGEMENT RULES, 2016 – REQUIREMENTS ON CONSTRUCTION AND DEMOLITION WASTE



Clause 4: Duties of waste generators:-

- (c) store separately construction and demolition waste, as and when generated, in his own premises and shall dispose off as per the Construction and Demolition Waste Management Rules, 2016;

Clause 15: Duties and responsibilities of local authorities:-

- (s) transport construction and demolition waste as per the provisions of the Construction and Demolition Waste management Rules, 2016;

### 3.7.2 CONSTRUCTION AND DEMOLITION WASTE RULES

Since construction and demolition waste was not given its due importance, there were very little efforts to keep records of its generation, composition, etc. However, it is estimated that 25–30 million tonne of C&D waste is generated annually in India. It has been further estimated that 40–60 kilogram per cubic meter ( $\text{kg/m}^3$ ) of C&D waste is generated during construction and minor repair or renovation. During demolition of proper concrete and masonry buildings (locally called pucca building), about  $500 \text{ kg/m}^3$  of C&D waste is generated whereas  $300 \text{ kg/m}^3$  is generated for structures with partial concreting and masonry. Presence of excavated soil and silt may change this

composition. Even in metro cities like Delhi and Mumbai, where C&D waste is collected separately, waste is mixed containing about 50% of soil and silt. Natural calamities like earthquakes, landslides, etc. result in generation of large quantities of C&D waste.

Construction and demolition waste does not include any waste which may have any chance of getting contaminated with nuclear waste or exposed to nuclear radiation. Special care shall be taken before demolition of any nuclear establishment.

Material generated from de-silting activity is also excluded from construction and demolition waste category as it contains decomposed organic material and may also contain heavy metals and other toxic materials. However, de-silted materials from natural drains and storm water drains, not contaminated with organic material, may be accepted as construction and demolition waste.



#### Composition of Construction and Demolition Waste

Construction and demolition (C&D) waste is complex due to the different types of building materials being used. In general, C&D waste may comprise the following materials:

Major components. Cement and concrete; bricks; cement plaster; steel (from reinforced concrete, door or window frames, roofing support, railings of staircase, etc.); rubble; stone (marble, granite, sand stone); timber or wood (especially demolition of old buildings)

Minor components. Conduits (iron, plastic); pipes (GI, iron, plastic); electrical fixtures (copper or aluminum wiring, wooden baton, Bakelite or plastic switches, wire insulation); panels (wooden, laminated); glazed tiles; glass panes; etc.

C&D wastes are heavy (due to high density), often bulky, and occupy considerable storage space. C&D wastes stored outside construction sites and along road sides are a cause of both traffic congestion and mishaps. These wastes are quite often given away for filling in low lying areas or plots to private agencies, or disposed at open spaces or on the road side illegally. Waste from small generators quite often finds its way into the nearest municipal bin, vat, waste storage depots, making the municipal waste heavy and degrading its quality for further treatment like composting or energy recovery. C&D waste is also often dumped in surface drains obstructing the flow of waste water leading to urban flooding.

The C&D Waste Rules have introduced the concept of “De-construction,” which means that a planned selective demolition in which salvage, reuse, and recycling of the demolished structure is maximized. This is made possible by a planned regime of construction

so that demolition is facilitated when desired. In a way, de-construction is “construction in reverse.” De-construction leads to less wastage and higher environmental sustainability.

### 3.7.3 RESPONSIBILITIES OF VARIOUS STAKEHOLDERS FOR CONSTRUCTION AND DEMOLITION WASTE MANAGEMENT

The waste generator, service provider, urban local body (ULB), and State Pollution Control Board (SPCB) and Pollution Control Committee (PCC) are the most important stakeholders for appropriate management of C&D waste. Construction and demolition waste rules, 2016 details out the duties of waste generator, service provider, ULBs, etc., and Schedule I explicitly describes the management of C&D waste.



#### Clause (4) Duties of the waste generator:-

- (1) Every waste generator shall prima-facie be responsible for collection, segregation of concrete, soil and others and storage of construction and demolition waste generated, as directed or notified by the concerned local authority in consonance with these rules.
- (2) The generator shall ensure that other waste (such as solid waste) does not get mixed with this waste and is stored and disposed separately.
- (3) Waste generators who generate more than 20 tonnes or more in one day or 300 tonnes per project in a month shall segregate the waste into four streams such as concrete, soil, steel, wood and plastics, bricks and mortar and shall submit waste management plan and get appropriate approvals from the local authority before starting construction or demolition or remodeling work and keep the concerned authorities informed regarding the relevant activities from the planning stage to the implementation stage and this should be on project to project basis.
- (4) Every waste generator shall keep the construction and demolition waste within the premise or get the waste deposited at collection centre so made by the local body or handover it to the authorised processing facilities of construction and demolition waste; and ensure that there is no littering or deposition of construction and demolition waste so as to prevent obstruction to the traffic or the public or drains.
- (5) Every waste generator shall pay relevant charges for collection, transportation, processing and disposal as notified by the concerned authorities; Waste generators who generate more than 20 tonnes or more in one day or 300 tonnes per project in a month shall have to pay for the processing and disposal of construction and demolition waste generated by them, apart from the payment for

storage, collection and transportation. The rate shall be fixed by the concerned local authority or any other authority designated by the State Government.



#### Clause (5) Duties of service provider and their contractors:-

- (1) The service providers shall prepare within six months from the date of notification of these rules, a comprehensive waste management plan covering segregation, storage, collection, reuse, recycling, transportation and disposal of construction and demolition waste generated within their jurisdiction.
- (2) The service providers shall remove all construction and demolition waste and clean the area every day, if possible, or depending upon the duration of the work, the quantity and type of waste generated, appropriate storage and collection, a reasonable timeframe shall be worked out in consultation with the concerned local authority.
- (3) In case of the service providers have no logistics support to carry out the work specified in sub- rules (1) and (2) , they shall tie up with the authorised agencies for removal of construction and demolition waste and pay the relevant charges as notified by the local authority.



#### Clause (6) Duties of local authority-The local authority shall:-

- (1) issue detailed directions with regard to proper management of construction and demolition waste within its jurisdiction in accordance with the provisions of these rules and the local authority shall seek detailed plan or undertaking as applicable, from generator of construction and demolition waste;
- (2) chalk out stages, methodology and equipment, material involved in the overall activity and final clean up after completion of the construction and demolition ;
- (3c) seek assistance from concerned authorities for safe disposal of construction and demolition waste contaminated with industrial hazardous or toxic material or nuclear waste if any;
- (4) shall make arrangements and place appropriate containers for collection of waste and shall remove at regular intervals or when they are filled, either through own resources or by appointing private operators;
- (5) shall get the collected waste transported to appropriate sites for processing and disposal either through own resources or by appointing private operators;
- (6) shall give appropriate incentives to generator for salvaging, processing and or recycling preferably in-situ;

- (7) shall examine and sanction the waste management plan of the generators within a period of one month or from the date of approval of building plan, whichever is earlier from the date of its submission;
- (8) shall keep track of the generation of construction and demolition waste within its jurisdiction and establish a data base and update once in a year;
- (9) shall device appropriate measures in consultation with expert institutions for management of construction and demolition waste generated including processing facility and for using the recycled products in the best possible manner;
- (10) shall create a sustained system of information, education and communication for construction and demolition waste through collaboration with expert institutions and civil societies and also disseminate through their own website;
- (11) shall make provision for giving incentives for use of material made out of construction and demolition waste in the construction activity including in non-structural concrete, paving blocks, lower layers of road pavements, colony and rural roads.



#### Clause (8) Duties of State Pollution Control Board or Pollution Control Committee:-

- (1) State Pollution Control Board or Pollution Control Committee shall monitor the implementation of these rules by the concerned local bodies and the competent authorities and the annual report shall be sent to the Central Pollution Control Board and the State Government or Union Territory or any other State level nodal agency identified by the State Government or Union Territory administration for generating State level comprehensive data. Such reports shall also contain the comments and suggestions of the State Pollution Control Board or Pollution Control Committee with respect to any comments or changes required;
- (2) State Pollution Control Board or Pollution Control Committee shall grant authorization to construction and demolition waste processing facility in Form-III as specified under these rules after examining the application received in Form I;
- (3) State Pollution Control Board or Pollution Control Committee shall prepare annual report in Form IV with special emphasis on the implementation status of compliance of these rules and forward report to Central Pollution Control Board before the 31<sup>st</sup> July for each financial year.

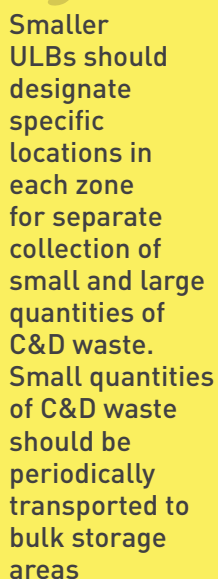

Smaller ULBs should designate specific locations in each zone for separate collection of small and large quantities of C&D waste. Small quantities of C&D waste should be periodically transported to bulk storage areas

(10) Duties of the Central Pollution Control Board - (1) The Central Pollution Control Board shall,-

- (a) prepare operational guidelines related to environmental management of construction and demolition waste management;
- (b) analyze and collate the data received from the State Pollution Control Boards or Pollution Control Committee to review these rules from time to time;
- (c) coordinate with all the State Pollution Control Board and Pollution Control Committees for any matter related to development of environmental standards;
- (d) forward annual compliance report to Central Government before the 30th August for each financial year based on reports given by State Pollution Control Boards of Pollution Control Committees.

(11) Duties of Bureau of Indian Standards and Indian Roads Congress - The Bureau of Indian Standards and Indian Roads Congress shall be responsible for preparation of code of practices and standards for use of recycled materials and products of construction and demolition waste in respect of construction activities and the role of Indian Road Congress shall be specific to the standards and practices pertaining to construction of roads.

### 3.7.4 MANAGEMENT OF CONSTRUCTION AND DEMOLITION WASTE

Schedule I of the construction and demolition waste management rules, specifies the management of construction and demolition waste. It details out guidance on storage, collection, transportation, processing, and disposal and also the use of the recycled products. Reuse, processing, and recycling have been emphasized. Large generators have to be incentivized for setting up in-situ processing facility. For large facilities, say for million plus cities, processing should be done through appropriate technology which minimizes process residues for landfilling, e.g., “wet” process, which can retrieve sand grade material (4.75 mm to 75  $\mu$ ) from soil and other fine inert material.

Schedule II provides for further use of processed C&D products in operation of sanitary landfill. It must be clarified that while processed C&D waste shall be utilized in sanitary landfill for MSW of the city or region, residues from C&D waste processing or recycling industries shall be landfilled in the sanitary landfill for MSW.

### 3.7.5 STORAGE COLLECTION TRANSPORTATION AND DISPOSAL OF CONSTRUCTION AND DEMOLITION WASTE

#### 3.7.5.1 SITE SELECTION FOR STORAGE, COLLECTION, PROCESSING AND RECYCLING OR PROCESSING FACILITIES FOR CONSTRUCTION AND DEMOLITION WASTE



Schedule I details out the compliance criteria for storage and processing or recycling facilities for C&D waste:-

- (1) The concerned department in the State Government dealing with land shall be responsible for providing suitable sites for setting up of the storage, processing and recycling facilities for construction and demolition and hand over the sites to the concerned local authority for development, operation and maintenance, which shall ultimately be given to the operators by Competent Authority and wherever above Authority is not available, shall lie with the concerned local authority.
- (2) The Local authority shall co-ordinate (in consultation with Department of Urban Development of the State or the Union territory) with the concerned organizations for giving necessary approvals and clearances to the operators.
- (3) Construction and demolition waste shall be utilized in sanitary landfill for municipal solid waste of the city or region as mentioned at Schedule I of these rules. Residues from construction and demolition waste processing or recycling industries shall be land filled in the sanitary landfill for solid waste.
- (4) The processing or recycling shall be large enough to last for 20-25 years (project based on-site recycling facilities).
- (5) The processing or recycling site shall be away from habitation clusters, forest areas, water bodies, monuments, National Parks, Wetlands and places of important cultural, historical or religious interest.
- (6) A buffer zone of no development shall be maintained around solid waste processing and disposal facility, exceeding five Tonnes per day of installed capacity. This will be maintained within the total area of the solid waste processing and disposal facility. The buffer zone shall be prescribed on case to case basis by the local authority in consultation with concerned State Pollution Control Board.
- (7) Processing or recycling site shall be fenced or hedged and provided with proper gate to monitor incoming vehicles or other modes of transportation.

- (8) The approach and or internal roads shall be concreted or paved so as to avoid generation of dust particles due to vehicular movement and shall be so designed to ensure free movement of vehicles and other machinery.
- (9) Provisions of weigh bridge to measure quantity of waste brought at landfill site, fire protection equipment and other facilities as may be required shall be provided.
- (10) Utilities such as drinking water and sanitary facilities (preferably washing/bathing facilities for workers) and lighting arrangements for easy landfill operations during night hours shall be provided and Safety provisions including health inspections of workers at landfill sites shall be carried out made.
- (11) In order to prevent pollution from processing or recycling operations, the following provisions shall be made, namely:
  - (a) Provision of storm water drains to prevent stagnation of surface water;
  - (b) Provision of paved or concreted surface in selected areas in the processing or recycling facility for minimizing dust and damage to the site.
  - (c) Prevention of noise pollution from processing and recycling plant:
  - (d) provision for treatment of effluent if any, to meet the discharge norms as per Environment (Protection) Rules, 1986.
- (12) Work Zone air quality at the Processing or Recycling site and ambient air quality at the vicinity shall be monitored.
- (13) The measurement of ambient noise shall be done at the interface of the facility with the surrounding area, i.e., at plant boundary.
- (14) The following projects shall be exempted from the norms of pollution from dust and noise as mentioned above: For construction work, where at least 80 percent construction and demolition waste is recycled or reused in-situ and sufficient buffer area is available to protect the surrounding habitation from any adverse impact.
- (15) A vegetative boundary shall be made around Processing or Recycling plant or site to strengthen the buffer zone.





**ULBs should make bye-laws as well as special arrangements for storage, transportation, processing and disposal of Construction and Demolition waste.**

**Small municipalities under 1 Lakh population should make simple arrangements as under:**

- Notify locations, preferably in each zone (North, South, East, West) and centre of the city, where waste generators having small quantities of C&D waste under 1 MT load should be allowed to deposit their waste. Construct an enclosure at each notified location for storage of small quantities of waste or place tractor trolley at each such location for storage of C&D waste.
- Arrange for transportation of C&D waste deposited at collection centres through covered tractor trolleys or trucks to the area designated for bulk storage.
- Citizens to avail of the facility at designated locations and refrain from disposal of C&D waste at any other location or in MSW bins.
- Plan for reuse and recycling of such waste with private sector participation or use the same for land reclamation by filling in low lying areas or for carrying out bio engineering works to prevent mosquito breeding, by using C&D waste to fill in areas where stagnant water is repeatedly observed.

**In cities above 1 Lakh population, the municipality should make elaborate arrangements as under:**

- Notify suitable locations in different parts of the city where waste generators having small quantities of C&D waste under 1MT load can deposit their waste conveniently.
- Create a system of renting skips or containers for storage of C&D waste at source departmentally or through an authorised private operator, where the generation of such waste is greater than 1 MT.
- Prescribed rates for collection and transportation of C&D waste to be published or notified.
- Citizens to avail the facility and refrain from disposal of small quantities of C&D waste anywhere else.
- Arrange for transportation of C&D waste through skip lifting system departmentally or through designated contractor. Normally 4.5 cu.m open skips and 10 cu.m roll on and roll of open containers (to be hauled by hook loaders are suitable for C&D waste.
- Plan for reuse and recycling of such waste with private sector participation. The rejects from these plants (soft fines) are used for filling in low lying areas.
- While depositing waste in the bins, care should be taken by the small generators to see that waste material is not dumped outside the bin or skip. These bins or skips should be periodically inspected by the municipal authority to ensure that they are cleared before they over flow. Littering should be strictly prohibited, particularly C&D waste should never be allowed to be deposited in open or covered drains.
- Large generators who are provided with open skips or tractor trolleys on rent by the local body or its authorised private operators, should inform the municipal authority or concerned agency when the containers are likely to be full in order to replace the filled skip or trolley with an empty one and transport the waste at

a designated site. In case of very large generators responsible for demolition, renovation, construction of infrastructure projects like bridges, fly-over, roads, large commercial or housing complex or demolition of unauthorised structures by municipality etc., the area should be screened and cordoned off and the material should be stacked systematically without obstructing traffic or causing any hindrance to the neighbourhood. Different waste components may be segregated and stored separately. Segregated material should be loaded into tipper lorries or tractors with the help of front end loaders or back hoes and transported to designated sites for further processing or other use. Private sector may be encouraged to facilitate reuse and recycling of C&D waste.

- The ULB should fix and notify charges for door step collection and transportation of C&D waste, based on the volume generated.
- Placement of Skips on Public Roads: Normally for bulk generators dedicated hook loader bins or skips may be provided at a cost wherever required and should be kept within the construction sites. The ULB should notify byelaws with regard to management of C&D waste and safety requirements of such containers on public roads.

### **3.7.5.2 BENEFITS OF PROCESSING CONSTRUCTION AND DEMOLITION WASTE**

- C&D waste can be put to a profitable use, given the scarcity of sand and stone for construction, thereby saving natural resources.
- It prevents public nuisance and traffic congestion issues arising from indiscriminate dumping of C&D waste.
- It saves valuable space at landfill sites.
- It reduces cost of bulk transportation if recycled close to source of generation.



## Experiences of first pilot project of Construction and Demolition waste Management in India

In 2009, the Municipal Corporation of Delhi (MCD) and IL&FS Environmental Infrastructure and Services Ltd. (IEISL) took an initiative of setting up a pilot project to process 500 tonnes per day (TPD) of construction and demolition (C&D) waste at Burari, Jahangirpuri, Delhi, which is a first of its kind plant in the country. A concession agreement for 10 years had been signed on public-private partnership (PPP) model, and 7 acres of land was provided by MCD for setting up the processing unit. Presently the project is in the jurisdiction of the North Delhi Municipal Corporation.

The project is based on an integrated approach covering collection and transportation of C&D waste from designated points by using skips and bins of different sizes (hailed by dumper placers or hook loaders) or tipping trucks with front-end loaders followed by transportation to the processing facility in vehicles fitted with GPS.

### Process flow

- Incoming waste is subjected to weighment at the site.
- Undesirable items like rags, plastics, metal, fibre reinforced plastic (FRP) sheets, etc. are segregated through mechanical and manual means.
- Remaining waste is segregated into three parts:
  - whole bricks (kept for internal use and sale),
  - large concrete, and
  - mixed C&D waste.
- Depending on the waste inflow and its quality, the waste is processed.

### Process Technology

Initially, the dry process was developed, in which loose soil was removed and the C&D waste was crushed and screened in stages to get the desired range of product sizes. However, in mixed C&D waste, considerable quantity of loose soil and grit is present which cannot be converted into useful products. To overcome this problem, the “wet” process was developed. In this process, the size grade of sand—4.75 mm to 75  $\mu$  (0.075 mm)—was extracted in the form of “manufactured sand.” The remaining fraction <75  $\mu$  was silt, which was removed. In this process, residue was drastically reduced.

- Collected C&D waste is first screened through the grizzly to remove loose soil and grit.
- Oversized screened materials are collected in the hand sorting section where bricks and concrete are separated.
- Segregated bigger concrete boulders as well as mixed concrete are broken using rock breakers. Thereafter crushing is done by jaw or impact (horizontal or vertical shaft) crusher, depending on the material, size of operation, and targeted end use.
- Multilayered vibro-screens with suitably sized interchangeable screens have been used for size grading the crushed material. This is the “dry” process. The different sizes of aggregates are used to make value-added products as mentioned below.
- In the wet process for extracting manufactured sand, C&D waste is crushed and then passed through a washing and screening train comprising log washer, vibro-screens (3-deck pro-grade screen), evo-wash, evo-screen, thickener and filter press to remove the silt material and recycle the water. Only about 15% make up water is needed to run the wet process.

- The wet processing technology is effective in controlling dust and noise, which is also important for compliance with the new rule.

### Final Products

The processed waste is being used for making road sub-base—granular sub-base (GSB)—and making pavement blocks and pre-cast products like curbstones, paver blocks, and square tiles. The loose soil separated by the grizzly is sold. The manufactured sand is used for making ready-mix concrete for nonstructural application and lean concrete.



In order to test the application of the recovered GSB from the plant, the roads within the plant as well as the access road to the plant (about 150 meter in length) were made with the recycled C&D aggregates.

Source: IEISL

### 3.7.5.3 REUSE AND RECYCLING POTENTIAL

Use of recycled C&D waste products (such as in non-structural concrete, manufactured sand, paving blocks, lower layers of road pavements, colony and rural roads etc.) shall be incentivised in places where there is an operational facility for recycling C&D waste. Such applications shall be subject to quality requirements for the specific application.

ii) Procurement of such materials shall be made mandatory (10-20%) in municipal and government contracts subject to strict quality control.

Many components of the C&D material have a high potential of reuse and recycling, as detailed in Table 3.15, provided they are properly segregated. Construction material such as aggregate, bricks, paving blocks etc. can also be made out of this waste.



#### Use of Construction and Demolition Waste for Road Works and Construction

- Experiments by Central Road Research Institute (CRRRI) have shown that it is possible to use construction and demolition (C&D) waste for road and embankment construction such as embankment and sub-grade, sub-base, stabilised base course, rigid pavement, etc.
- The Government of National Capital Territory (Delhi) has accorded exemption of VAT for tiles and curbstones made from C&D waste or “malba”.<sup>51</sup>

51 Construction, demolition debris chokes Delhi. Hindustan Times. 1 April. Singh, D. 2013. <http://www.hindustantimes.com/india-news/newdelhi/construction-demolition-debris-chokes-delhi/article1-1035318.aspx>

The following table indicates some use potential of different components of recycled C&D waste material. However, care has to be taken in keeping durability and structural considerations in mind while planning such use.

**Table 3.15: C&D Wastes and Their Reuse Potential** <sup>52</sup>

| <b>MATERIAL</b>  | <b>PROCESS</b>   | <b>END USE</b>   |
|--|--|--|
| <b>Demolition waste</b>  | Crushed and sorted                                       | Recycled aggregate   |
| <b>Construction waste</b>  | Washed to remove cement and recover aggregate            | Recycled aggregate   |
| <b>Reinforced concrete</b>   | Crushed, sorted and steel bars removed<br>Steel recycled | Recycled concrete aggregate<br>For recycling                                 |
| <b>Clay bricks and roof tiles</b>                                  | Cleaned<br>Crushed and sorted<br>Pulverised              | Reused for masonry<br>Aggregate<br>Mixed with lime to produce mortar         |
| <b>Calcium silicate bricks</b>                                     | Cleaned<br>Crushed<br>Pulverised                         | Reused for masonry<br>Aggregate<br>Recycled into new calcium silicate bricks |
| <b>Natural stone masonry</b>                                       | Cleaned<br>Crushed                                       | Reused for masonry<br>Aggregate  |
| <b>Natural stone slabs</b>   | Cleaned<br>Crushed                                       | Flooring, cladding<br>Aggregate  |
| <b>Ceramic tiles</b>   | Cleaned<br>Crushed                                       | Flooring, cladding<br>Aggregate  |
| <b>Asphalt paving</b>  | Crushed and cold mixed<br>Crushed and hot mixed          | Road construction excluding wearing course                                   |
| <b>Mixed demolition waste (ABC i.e. asphalt, bricks, concrete)</b> | Crushed  | Fill material  |
| <b>Steel</b>   | Cleaned<br>Recycled                                      | Reused steel components<br>New steel components                              |
| <b>Aluminium</b>   | Cleaned<br>Recycled                                      | Aluminium recycling streams  |
| <b>Timber beams, doors etc.</b>                                    | Cleaned  | Reused as beams, doors etc. (if free of hazardous preservatives).            |
| <b>Timber boards</b>   | Cleaned  | Reused as shuttering and other products<br>Feedstock for engineered woods    |
| <b>Plastics</b>  | Recycled   | Plastic recycling streams  |
| <b>Gypsum plasterboard</b>   | Cleaned<br>Crushed<br>Recycled                           | Reuse as boards<br>Soil conditioner<br>New gypsum products                   |
| <b>Glass</b>   | Cleaned<br>Crushed<br>Recycled                           | Glass recycling streams  |

<sup>52</sup> "Reuse and Recycling of Construction and Demolition Waste". Holcim & GIZ, (2007).

### 3.7.5.4 PROPOSED USE FOR PROCESSED CONSTRUCTION AND DEMOLITION WASTE

The use of the processed construction and demolition waste has been described below, primarily mixed aggregates or recycled aggregates (RA) as well as recycled concrete aggregates (RCA).

- (i) Recycled aggregate (RA) may be used in making concrete for non-structural purposes. The extent of use would be limited to non-load bearing structures only, provided the conditions mentioned below at point no. 2 is complied with. Examples of use – wall between two RCC load bearing members, filling walls between RCC frame, non-industrial flooring, etc.
- (ii) The RA shall be free from deleterious material, such as, organic content, vegetable matter, coal, clay lumps, external substances such as, soft fragments like pieces of plastics, paper etc. RA shall also be free from chemicals, known to be detrimental for the strength or durability of concrete or steel reinforcement, such as, chlorides, etc. beyond the threshold value.
- (iii) Percentage of replacement of natural aggregates by RA can be up to 20% for any type of plain concrete work. The percentage can be increased up to 30% for road sub-base / base / other road related applications except wearing course. However, this shall be backed up by laboratory test reports.
- (iv) RA of appropriate quality (as mentioned above) can be used for various purposes, such as, in making kerb stones, paving blocks, concrete blocks and bricks, road sub-base, pathways for pedestrian use, rural roads (used for walking and bicycles) etc. However, it has to be ensured that the existing norms for strength (such as, M20, M25 etc.) are complied with for desired application.
- (v) Recycled concrete aggregate (RCA) can be used in all grades of PCC (non-structural and structural).
- (vi) Recycled concrete aggregates have to be pre-wetted near to SSD (saturated surface dry) conditions before use to avoid rapid slump loss due to its high water absorption rate. Admixtures with better slump retention effect would be useful.
- (vii) Fine washed aggregates in the range of 4.75 mm to 0.075 mm (75  $\mu$ ) separated from C&D waste using 'wet' process may be used as 'manufactured sand' for non-load bearing structures.

### **3.7.6 SITING AND MANAGING CONSTRUCTION AND DEMOLITION RECYCLING PLANTS**

#### **3.7.6.1 IDENTIFICATION OF APPROPRIATE LAND FOR CONSTRUCTION AND DEMOLITION PROCESSING FACILITIES**

The Town and Country Planning Department or Urban Development Department of the State or other Competent Authority should identify suitable site(s) for setting up processing facilities for construction and demolition waste according to the parameters necessary for such projects. The identified land should be incorporated in the approved land use plan so that there is no disturbance to the processing facility on a long term basis. 'No Development Zone' should be notified around the site to safeguard the facility.

#### **3.7.6.2 SITING CRITERIA FOR STORAGE AND PROCESSING FACILITIES**

Consideration of environmental issues and suitability as well as adequacy of the chosen sites are the main criteria. A 'buffer zone of no development' shall be maintained—20 m for handling less than 500 tonnes per day (TPD) of C&D waste and 30 m for 500 TPD or more—around processing or recycling site and shall be incorporated in the land use plans of the concerned authority. In the case of successful implementation of 'no development zone,' the buffer zone inside the facility boundary should be limited to 6 m (for less than 500 TPD of C&D waste) and 10 m (for 500 or more TPD of C&D waste). Thus, land required for the facility would reduce.

In case the urban local body (ULB) or development authority is unable to procure a site where it is not feasible to provide any 'no development zone,' the ULB would constitute a committee comprising representation from the State Urban Development Department, State Pollution Control Board (SPCB) and Pollution Control Committee, and at least one expert institution to deliberate on the long-term impact and then give recommendations to the ULB. In case they recommend any specific technology or modification in design of the facility, the same should be incorporated in the bid. This way the project would be secure from objections from the neighbourhood for siting of the plant or facility. C&D recycling plants should ideally be installed in an industrial area or zone or adjacent to an existing or future landfill site.



### **In-situ Recycling of C&D Waste at Redevelopment Site by National Buildings Construction Corporation (NBCC): A New Example for India**

An old government colony of about 2,500 dwelling units is being redeveloped at East Kidwai Nagar in New Delhi. The huge quantity of construction and demolition (C&D) waste generated at the site is being recycled at a facility set up within the site. The process involves crushing of the C&D waste material in a crusher housed underground followed by further grinding in an overground milling machine. The fine material is mixed with a patented catalyst in a pan mixer and the mixture is passed through a brick making machine. The green bricks are sun dried or cured in the sun for 4 weeks. The bricks are of standard size and would be used in the buildings coming up at the site. This in-situ recycling of C&D waste has avoided the need of transportation of C&D waste, resulting in substantial saving in transportation cost, and has minimised environmental degradation. The initiative will also save scarce land resource which is also increasingly getting difficult to procure.



*Note: This being a new experiment in India, strength and durability of the bricks need to be monitored on a long-term basis.*

C&D waste processing or recycling facilities should be located at least 500m away from the boundary of residential areas, preferably in industrial zones or adjacent to landfill sites

### **3.7.7 ENVIRONMENTAL CONSIDERATIONS**

Dust and noise are usually the main issues with processing facilities for C&D waste. Table 3.16 provides a summary of environmental issues which need to be addressed during installation and operation of C&D plants.





**Table 3.16: Potential Environmental Issues with Siting and Managing a Construction and Demolition Recycling Facility<sup>53</sup>**

| <b>ACTIVITY</b>   | <b>POTENTIAL ISSUE</b>  | <b>IMPACTS</b>  |
|---|---|---|
| <b>Site clearing</b>  | Dust and noise<br>Loss of biodiversity  | Health<br>Air pollution<br>Ambience or visual impact<br>Flora and fauna habitat |
| <b>Site operations or contouring that permits water to pond on-site</b>   | Odour   | Health<br>Ambience or visual impact   |
| <b>Uncontrolled or poorly managed site run-off</b>  | Surface water run-off resulting in transportation of sediments (i.e. erosion)                         | Water pollution<br>Soil erosion   |
| <b>Transporting materials to or from site or stockpiling of wastes or recycled products on site. Crushing, grinding or screening operations</b> | Dust<br>Noise   | Health<br>Air pollution<br>Ambience   |
| <b>Asbestos contamination in waste loads</b>  | Asbestos pieces pass through crushing operations<br>Asbestos from stockpiled material remains in soil | Health<br>Air pollution<br>Land contamination                                   |
| <b>Sorting of C&amp;D waste</b>   | Hazardous waste components of C&D waste   | Health<br>Air pollution<br>Land contamination                                   |
| <b>Litter</b>   | Litter from operations or during transportation to or from site                                       | Littering, choking of drains  |

For prevention of pollution from processing or recycling operations, certain provisions have been mandated such as storm water drain and paving or concreting of selected areas in the processing or recycling facility.

<sup>53</sup> Source: Environment Guideline for C&D waste recycling Facilities, Department of Environment and Conservation, The Government of Western Australia

**Table 3.17: Ambient Air Quality at the Processing or Recycling Site and in the Vicinity<sup>54</sup>**

| SL. NO. | PARAMETERS   | ACCEPTABLE LEVEL   |
|---------|--|--|
| (i)     | Suspended Particulate Matter   | 500 µg/m <sup>3</sup> (24 hours)                                   |
| (ii)    | Respirable Suspended Particulate Matter (RSPM) or Particulate Matter (PM <sub>10</sub> ) 10 Micron | 100 µg/m <sup>3</sup> (24 hourly)<br>60 µg/m <sup>3</sup> (annual) |
| (iii)   | Particulate Matter ≥ size (PM <sub>2.5</sub> )   | 60 µg/m <sup>3</sup> (24 Hourly)<br>40 µg/m <sup>3</sup> (Annual)  |

The ambient air quality monitoring (Table 3.17) shall be carried out at processing or recycling sites by the concerned authority as per the following schedule:

- a. six times a year for cities having a population of more than 5 million;
- b. four times a year for cities having a population between 1 million and 5 million;
- c. two times a year for town or cities having a population between 100,000 and 1 million; or
- d. once a year for all towns (including census towns) having a population below 100,000.

For noise levels, the noise standards recommended by Central Pollution Control Board (CPCB) and notified in the Environment (Protection) Rules, 1986 for industrial area shall be applicable (daytime 75 dB ALeq and night time 70 dB ALeq). The measurement would be done at the interface of the facility with the surrounding area, i.e., at plant boundary.

However, exemption from dust and noise provisions has been granted for the following projects:

1. for redevelopment of colonies and markets, where in-situ recycling is carried out, provided (a) the project is completed within 5 years, (b) minimum 80% of the C&D waste generated at the site is recycled or reused within the same site, and (c) sufficient buffer area is available to protect the surrounding habitation from any adverse impact; and
2. in-situ recycling at large construction sites (minimum 1 hectare so that some buffer area is available), provided (a) the project is completed within 3 years, and (b) minimum 50% of the C&D waste generated at the site is reused or recycled within the same site.

<sup>54</sup> Revised National Ambient Air Quality Standards (NAAQS), Ministry of Environment Forest and Climate Change, 2009. <http://www.moef.nic.in/sites/default/files/notification/Recved%20national.pdf>



### 3.8 ACTION POINTS FOR AWARENESS GENERATION THROUGH INFORMATION, EDUCATION, AND COMMUNICATION ACTIVITIES FOR TECHNICAL ASPECTS OF PROCESSING AND TREATMENT OF MUNICIPAL SOLID WASTE

- Ensure active participation of the community for recycling waste at household level. Recycling reduces the overall quantities of waste to be treated.
- Success of any recycling programme depends on community cooperation.
  - Sensitise community toward waste pickers.
  - Conduct recycling programmes at ward level and schools to generate public awareness.
- Generate public awareness to segregate dry and wet waste at source. The success of any waste treatment technology will depend on raw materials received, which eventually depends on segregation of waste.
- Ensure community participation toward successful implementation of decentralised waste management system like composting and vermicomposting.
- Involve community while planning and designing any waste management system to avoid disagreement at later stages, especially during siting of plant.
- Inform community about various existing and new waste treatment technologies and requirements.
- Encourage the utilisation of compost for farming and gardening. Increasing public awareness and knowledge about compost use and benefits will subsequently lead to increased market demand of compost.
- Involve agricultural department officers in generating awareness on compost usage.
- Public support for adopting decentralised waste treatment technologies (e.g., vermicomposting and biomethanation) ensures success of treatment technologies and minimises financial implications for ULBs.
- Generate community awareness to avoid “not in my backyard” (NIMBY) syndrome, so that land can be earmarked for a decentralised waste treatment facility.



# 4

## **Technical Aspects:** Municipal Sanitary Landfills

## IN THIS SECTION

|     |   |     |
|-----|---|-----|
| 4.1 | Solid Waste Management Rules, 2016 - on Landfills   | 351 |
| 4.2 | Environmental Impacts and its Minimisation  | 359 |
| 4.3 | Types of Municipal Solid Waste to be Accepted at Landfills  | 359 |
| 4.4 | Essential Components of Municipal Sanitary Landfills  | 360 |
| 4.5 | Planning and Design of a Landfill   | 361 |
| 4.6 | Action Points for Awareness Generation through Information, Education,<br>and Communication Activities for Municipal Sanitary Landfills | 423 |

## 4. TECHNICAL ASPECTS: MUNICIPAL SANITARY LANDFILLS

### 4.1 SOLID WASTE MANAGEMENT RULES, 2016 - ON LANDFILLS



As per SWM Rules, 2016:

**Clause 15: Duties and responsibilities of local authorities:-**

- (zh) stop land filling or dumping of mixed waste soon after the timeline as specified in rule 23 for setting up and operationalisation of sanitary landfill is over;
- (zi) allow only the non-usable, non-recyclable, non-biodegradable, non-combustible and non-reactive inert waste and pre-processing rejects and residues from waste processing facilities to go to sanitary landfill and the sanitary landfill sites shall meet the specifications as given in Schedule-I, however, every effort shall be made to recycle or reuse the rejects to achieve the desired objective of zero waste going to landfill;
- (zj) investigate and analyse all old open dumpsites and existing operational dumpsites for their potential of bio- mining and bio-remediation and wheresoever feasible, take necessary actions to bio-mine or bio-remediate the sites;
- (zk) in absence of the potential of bio-mining and bio-remediation of dumpsite, it shall be scientifically capped as per landfill capping norms to prevent further damage to the environment.



**Clause 20: Criteria and actions to be taken for solid waste management in hilly areas:**

- (a) Construction of landfill on the hill shall be avoided. A transfer station at a suitable enclosed location shall be setup to collect residual waste from the processing facility and inert waste. A suitable land shall be identified in the plain areas down the hill within 25 kilometers for setting up sanitary landfill. The residual waste from the transfer station shall be disposed of at this sanitary landfill.
- (b) In case of non-availability of such land, efforts shall be made to set up regional sanitary landfill for the inert and residual waste.

## SCHEDULE I: SPECIFICATIONS FOR LANDFILLS SITES



### (A) Criteria for site selection:-

#### Specifications for Sanitary Landfills

- (i) The department in the business allocation of land assignment shall provide suitable site for setting up of the solid waste processing and treatment facilities and notify such sites.
- (ii) The sanitary landfill site shall be planned, designed and developed with proper documentation of construction plan as well as a closure plan in a phased manner. In case a new landfill facility is being established adjoining an existing landfill site, the closure plan of existing landfill should form a part of the proposal of such new landfill.
- (iii) The landfill sites shall be selected to make use of nearby wastes processing facilities. Otherwise, wastes processing facility shall be planned as an integral part of the landfill site.
- (iv) Landfill sites shall be set up as per the guidelines of the Ministry of Urban Development, Government of India and Central Pollution Control Board.
- (v) The existing landfill sites which are in use for more than five years shall be improved in accordance with the specifications given in this Schedule.
- (vi) The landfill site shall be large enough to last for at least 20-25 years and shall develop 'landfill cells' in a phased manner to avoid water logging and misuse.
- (vii) The landfill site shall be 100 meter away from river, 200 meter from a pond, 200 meter from Highways, Habitations, Public Parks and water supply wells and 20 km away from Airports or Airbase. However in a special case, landfill site may be set up within a distance of 10 and 20 km away from the Airport/Airbase after obtaining no objection certificate from the civil aviation authority/ Air force as the case may be. The Landfill site shall not be permitted within the flood plains as recorded for the last 100 years, zone of coastal regulation, wetland, Critical habitat areas, sensitive eco-fragile areas..
- (viii) The sites for landfill and processing and disposal of solid waste shall be incorporated in the Town Planning Department's land-use plans.
- (ix) A buffer zone of no development shall be maintained around solid waste processing and disposal facility, exceeding five Tonnes per day of installed capacity. This will be maintained within the total



area of the solid waste processing and disposal facility. The buffer zone shall be prescribed on case to case basis by the local body in consultation with concerned State Pollution Control Board.

- (x) The biomedical waste shall be disposed of in accordance with the Bio-medical Waste Management Rules, 2016, as amended from time to time. The hazardous waste shall be managed in accordance with the Hazardous and Other Wastes (Management and Transboundary Movement) Rules, 2016, as amended from time to time. The E-waste shall be managed in accordance with the e-waste (Management ) Rules, 2016 as amended from time to time.
- (xi) Temporary storage facility for solid waste shall be established in each landfill site to accommodate the waste in case of non- operation of waste processing and during emergency or natural calamities.

**(B) Criteria for development of facilities at the sanitary landfills:-**



- (i) Landfill site shall be fenced or hedged and provided with proper gate to monitor incoming vehicles, to prevent entry of unauthorised persons and stray animals
- (ii) The approach and / internal roads shall be concreted or paved so as to avoid generation of dust particles due to vehicular movement and shall be so designed to ensure free movement of vehicles and other machinery.
- (iii) The landfill site shall have waste inspection facility to monitor waste brought in for landfilling h, office facility for record keeping and shelter for keeping equipment and machinery including pollution monitoring equipment. The operator of the facility shall maintain record of waste received, processed and disposed.
- (iv) Provisions like weigh bridge to measure quantity of waste brought at landfill site, fire protection equipment and other facilities as may be required shall be provided.
- (v) Utilities such as drinking water and sanitary facilities (preferably washing/bathing facilities for workers) and lighting arrangements for easy landfill operations during night hours shall be provided.
- (vi) Safety provisions including health inspections of workers at landfill sites shall be carried out made.
- (vii) Provisions for parking, cleaning, washing of transport vehicles carrying solid waste shall be provided. The wastewater so generated shall be treated to meet the prescribed standards.



(C) **Criteria for specifications for land filling operations and closure on completion of land filling:-**

- (i) Waste for land filling shall be compacted in thin layers using heavy compactors to achieve high density of the waste. In high rainfall areas where heavy compactors cannot be used, alternative measures shall be adopted.
- (ii) Till the time waste processing facilities for composting or recycling or energy recovery are set up, the waste shall be sent to the sanitary landfill. The landfill cell shall be covered at the end of each working day with minimum 10 cm of soil, inert debris or construction material.
- (iii) Prior to the commencement of monsoon season, an intermediate cover of 40-65 cm thickness of soil shall be placed on the landfill with proper compaction and grading to prevent infiltration during monsoon. Proper drainage shall be constructed to divert run-off away from the active cell of the landfill.
- (iv) After completion of landfill, a final cover shall be designed to minimise infiltration and erosion. The final cover shall meet the following specifications, namely :-
  - a) The final cover shall have a barrier soil layer comprising of 60 cm of clay or amended soil with permeability coefficient less than  $1 \times 10^{-7}$  cm/sec.
  - b) On top of the barrier soil layer, there shall be a drainage layer of 15 cm.
  - c) On top of the drainage layer, there shall be a vegetative layer of 45 cm to support natural plant growth and to minimise erosion.



(D) **Criteria for pollution prevention.-In order to prevent pollution from landfill operations, the following provisions shall be made, namely:-**

- (i) The storm water drain shall be designed and constructed in such a way that the surface runoff water is diverted from the landfilling site and leachates from solid waste locations do not get mixed with the surface runoff water. Provisions for diversion of storm water discharge drains shall be made to minimise leachate generation and prevent pollution of surface water and also for avoiding flooding and creation of marshy conditions.
- (ii) Non-permeable lining system at the base and walls of waste disposal area. For landfill receiving residues of waste processing facilities or mixed waste or waste having contamination of hazardous materials (such as aerosols, bleaches, polishes, batteries, waste oils, paint products and pesticides) shall have liner of composite barrier of 1.5 mm thick high density polyethylene (HDPE) geo-membrane or geo-synthetic liners, or equivalent, overlying 90 cm of soil (clay or amended

soil) having permeability coefficient not greater than  $1 \times 10^{-7}$  cm/sec. The highest level of water table shall be at least two meter below the base of clay or amended soil barrier layer provided at the bottom of landfills.

- (iii) Provisions for management of leachates including its collection and treatment shall be made. The treated leachate shall be recycled or utilized as permitted, otherwise shall be released into the sewerage line, after meeting the standards specified in Schedule- II.. In no case, leachate shall be released into open environment.
- (iv) Arrangement shall be made to prevent leachate runoff from landfill area entering any drain, stream, river, lake or pond. In case of mixing of runoff water with leachate or solid waste, the entire mixed water shall be treated by the concern authority.



**(E) Criteria for water quality monitoring:-**

- (i) Before establishing any landfill site, baseline data of ground water quality in the area shall be collected and kept in record for future reference. The ground water quality within 50 meter of the periphery of landfill site shall be periodically monitored covering different seasons in a year that is, summer, monsoon and post-monsoon period to ensure that the ground water is not contaminated.
- (ii) Usage of groundwater in and around landfill sites for any purpose (including drinking and irrigation) shall be considered only after ensuring its quality. The following specifications for drinking water quality shall apply for monitoring purpose, namely :-

| S. NO. | PARAMETERS   | IS 10500:2012, EDITION 2.2(2003-09)<br>DESIRABLE LIMIT (MG/L EXCEPT FOR PH) |
|--------|--|---|
| 1      | Arsenic  | 0.01  |
| 2      | Cadmium  | 0.01  |
| 3      | Chromium (as Cr <sup>6+</sup> )                          | 0.05  |
| 4      | Copper   | 0.05  |
| 5      | Cyanide  | 0.05  |
| 6      | Lead   | 0.05  |
| 7      | Mercury  | 0.001   |
| 8      | Nickel   | -   |
| 9      | Nitrate as NO <sub>3</sub>                               | 45.0  |
| 10     | pH   | 6.5-8.5   |
| 11     | Iron   | 0.3   |
| 12     | Total hardness (as CaCO <sub>3</sub> )                   | 300.0   |
| 13     | Chlorides  | 250   |
| 14     | Dissolved solids   | 500   |
| 15     | Phenolic compounds as (C <sub>6</sub> H <sub>5</sub> OH) | 0.001   |
| 16     | Zinc   | 5.0   |
| 17     | Sulphate (as SO <sub>4</sub> )                           | 200   |



**(F) Criteria for ambient air quality monitoring:-**

- (i) Landfill gas control system including gas collection system shall be installed at landfill site to minimize odour, prevent off-site migration of gases, to protect vegetation planted on the rehabilitated landfill surface. For enhancing landfill gas recovery, use of geomembranes in cover systems along with gas collection wells should be considered.
- (ii) The concentration of methane gas generated at landfill site shall not exceed 25 per cent of the lower explosive limit (LEL).
- (iii) The landfill gas from the collection facility at a landfill site shall be utilized for either direct thermal applications or power generation, as per viability. Otherwise, landfill gas shall be burnt (flared) and shall not be allowed to escape directly to the atmosphere or for illegal tapping. Passive venting shall be allowed in case if its utilisation or flaring is not possible.
- (iv) Ambient air quality at the landfill site and at the vicinity shall be regularly monitored. Ambient air quality shall meet the standards prescribed by the Central Pollution Control Board for Industrial area.



**G. Criteria for plantation at landfill site:- A vegetative cover shall be provided over the completed site in accordance with the following specifications, namely:-**

- (a) Locally adopted non-edible perennial plants that are resistant to drought and extreme temperatures shall be planted;
- (b) The selection of plants should be of such variety that their roots do not penetrate more than 30 cms. This condition shall apply till the landfill is stabilized;
- (c) Selected plants shall have ability to thrive on low-nutrient soil with minimum nutrient addition; (d) Plantation to be made in sufficient density to minimise soil erosion.
- (e) Green belts shall be developed all around the boundary of the landfill in consultation with State Pollution Control Boards or Pollution Control Committees.



**H. Criteria for post-care of landfill site:-**

- (1) The post-closure care of landfill site shall be conducted for at least fifteen years and long term monitoring or care plan shall consist of the following, namely :-
  - (a) Maintaining the integrity and effectiveness of final cover, making repairs and preventing run-on and run-off from eroding or otherwise damaging the final cover;



**As per Municipal Solid Waste Management Rules 2000, to monitor the ambient air quality at the landfill site, the following specified standards should be met:**

### Standards for Ambient Air Quality around Landfill Sites

| S. NO. | PARAMETERS  | ACCEPTABLE LEVELS   |
|--------|---|---|
| (i)    | Sulphur dioxide   | 50 µg/m <sup>3</sup> (Annual*)<br>80 µg/m <sup>3</sup> (24 hours**)   |
| (ii)   | Nitrogen dioxide  | 40 µg/m <sup>3</sup> (Annual*)<br>80 µg/m <sup>3</sup> (24 hours**)   |
| (iii)  | Particulate matter (size less than 10µ) or PM <sub>10</sub>       | 60 µg/m <sup>3</sup> (Annual*)<br>100 µg/m <sup>3</sup> (24 hours**)  |
| (iv)   | Particulate matter (size less than 2.5 µ) or PM <sub>2.5</sub>    | 40 µg/m <sup>3</sup> (Annual*)<br>60 µg/m <sup>3</sup> (24 hours**)   |
| (v)    | Carbon monoxide   | 1 hour ** : 04 mg/m <sup>3</sup><br>8 hours** : 02 mg/m <sup>3</sup>  |
| (vi)   | Ammonia (NH <sub>3</sub> ) µg/m <sup>3</sup>                      | 100 µg/m <sup>3</sup> (Annual*)<br>400 µg/m <sup>3</sup> (24 hours**) |
| (vii)  | Benzo (a) pyrene (BaP)- particulate phase only, ng/m <sup>3</sup> | 01 ng/m <sup>3</sup> (Annual*)  |

#### Notes:

\* Annual arithmetic mean of minimum 104 measurements in a year at a particular site taken twice a week 24 hourly at uniform intervals.

\*\* 24 hourly or 08 hourly or 01 hourly monitored values, as applicable, shall be complied with 98% of the time in a year, 2% of the time, they may exceed the limits but not on two consecutive days of monitoring.

- The ambient air quality monitoring shall be carried out by the concerned authority as per the following schedule, namely:-
  - (a) Six times in a year for cities having population of more than fifty lakhs;
  - (b) Four times in a year for cities having population between ten and fifty lakhs;
  - (c) Two times in a year for town or cities having population between one and ten lakhs.

- (b) Monitoring leachate collection system in accordance with the requirement;
- (c) Monitoring of ground water in and around landfill;
- (d) Maintaining and operating the landfill gas collection system to meet the standards.

(2) Use of closed landfill sites after fifteen years of post-closure monitoring can be considered for human settlement or otherwise only after ensuring that gaseous emission and leachate quality analysis complies with the specified standards and the soil stability is ensured.



### I. Criteria for special provisions for hilly areas:-

Cities and towns located on hills shall have location-specific methods evolved for final disposal of solid waste by the local body with the approval of the concerned State Pollution Control Board or the Pollution Control Committee. The local body shall set up processing facilities for utilisation of biodegradable organic waste. The non-biodegradable recyclable materials shall be stored and sent for recycling periodically. The inert and non-biodegradable waste shall be used for building roads or filling-up of appropriate areas on hills. In case of constraints in finding adequate land in hilly areas, waste not suitable for road-laying or filling up shall be disposed of in regional landfills in plain areas.



### J. Closure and rehabilitation of old dumps:-

Solid waste dumps which have reached their full capacity or those which will not receive additional waste after setting up of new and properly designed landfills should be closed and rehabilitated by examining the following options:

- (i) Reduction of waste by bio mining and waste processing followed by placement of residues in new landfills or capping as in (ii) below.
- (i). Capping with solid waste cover or solid waste cover enhanced with geomembrane to enable collection and flaring / utilisation of greenhouse gases.
- (iii) Capping as in (ii) above with additional measures (in alluvial and other coarse grained soils) such as cut-off walls and extraction wells for pumping and treating contaminated ground water.
- (iv) Any other method suitable for reducing environmental impact to acceptable level.

## 4.2 ENVIRONMENTAL IMPACTS AND ITS MINIMISATION

In line with the Solid Waste Management (SWM) Rules, 2016 as documented in Section 4.1, sanitary landfills minimise the harmful impact of solid waste on the environment through the use of the following mechanisms:

- a) reduction of groundwater contamination through leachate collection and treatment;
- b) control of surface water contamination through runoff;
- c) reduction of air contamination due to gases, litter, dust, or bad odour;
- d) control of other problems due to rodents, pests, fire, bird menace, slope failure, erosion, etc.

## 4.3 TYPES OF MUNICIPAL SOLID WASTE TO BE ACCEPTED AT LANDFILLS

Waste categories suitable for sanitary landfills are the following:

- i) non-biodegradable and inert waste by nature or through pre-treatment;
- ii. commingled waste (mixed waste) not found suitable for waste processing;
- iii. pre-processing and post-processing rejects from waste processing sites; and
- iv. non-hazardous waste not being processed or recycled.

Sanitary landfilling is not mandated or required for the following waste streams in the municipal solid waste (MSW):

- (i) biodegradable waste or garden waste,
- (ii) dry recyclables, and
- (iii) hazardous waste or industrial waste (to be disposed in hazardous waste sites with special containment).

Hazardous wastes have to be disposed of in special facilities—e.g., treatment, storage, and disposal facilities (TSDF)—that are designed for the respective types of waste. MSW having limited contamination of hazardous materials—e.g., aerosols, household chemicals, used batteries, contaminated containers like paint, etc. can be disposed of in a sanitary landfill with adequate liner systems (see requirements in SWM Rules, 2016). However, in line with this manual, such wastes should be segregated at source and managed appropriately, minimising their disposal in sanitary landfills.

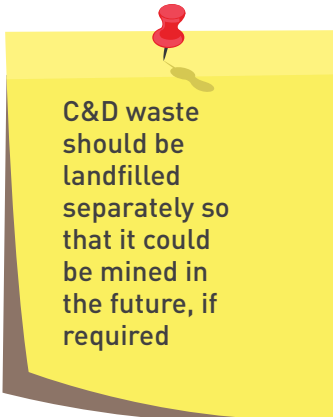

C&D waste should be landfilled separately so that it could be mined in the future, if required

Landfilling of construction and demolition (C&D) waste, where processing options are not available, will be done in a separate landfill or cell where the waste can be stored and mined for future use in earthwork or road projects. C&D waste can be used as a daily cover or for road construction at the MSW sanitary landfill.

#### 4.4 ESSENTIAL COMPONENTS OF MUNICIPAL SANITARY LANDFILLS

The term sanitary landfill is used herein to describe a unit operation for final disposal of 'Municipal Solid Waste' on land, designed and constructed with the objective of minimising impact to the environment and according to the SWM Rules.

Figure 4.1: Section of Typical Sanitary Landfill<sup>1</sup>

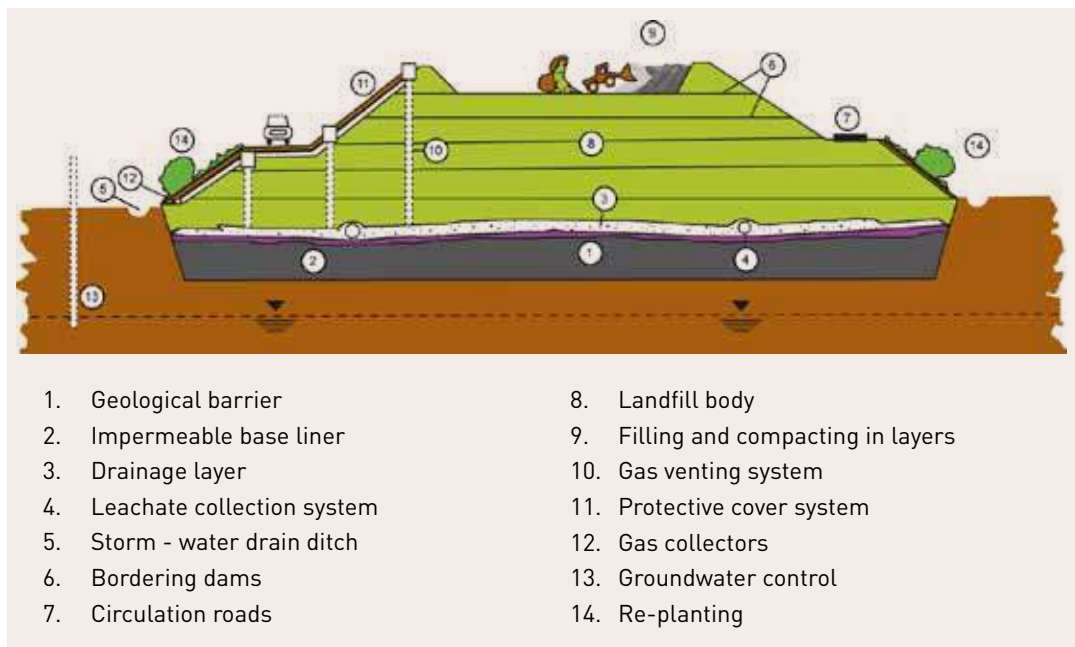

Figure 4.1 illustrates the essential components of a MSW sanitary landfill which include:

- a liner system at the base and sides of the sanitary landfill which prevents migration of leachate or gas to the surrounding soil;
- a leachate collection and control facility which collects and extracts leachate from within and from the base of the sanitary landfill and then treats the leachate;
- a gas collection and control facility (optional for small sanitary landfills) which collects and extracts gas from within and from the top of the sanitary landfill and then treats it or uses it for energy recovery;

<sup>1</sup> Developed by the Expert Committee for revision of MSWM manual (2013-15)



- a final cover system at the top of the sanitary landfill which enhances surface drainage, prevents infiltrating water, and supports surface vegetation;
- a surface water drainage system which collects and removes all surface runoff from the sanitary landfill site;
- an environmental monitoring system which periodically collects and analyses air, surface water, soil, gas, and groundwater samples around the sanitary landfill site; and
- a closure and post-closure plan which lists the steps that must be taken to close and secure a sanitary landfill site once the filling operation has been completed and the activities for long-term monitoring and operation and maintenance (O&M) of the completed sanitary landfill are functional.

## 4.5 PLANNING AND DESIGN OF A LANDFILL

Steps for designing, implementation and operation of a Sanitary Landfill are:

1. site selection,
2. sanitary landfill design,
3. construction of a sanitary landfill,
4. sanitary landfill operation, and
5. closure and post-closure plan.

### 4.5.1 SITE SELECTION

Selection of a sanitary landfill site shall be governed by the strategy identified in the state policy and SWM strategy and the municipal solid waste management (MSWM) plan of the urban local body (ULB). Decisions on constructing local landfills in relation to utilising regional landfills are based on these strategies or planning documents.

Site selection usually includes the following steps, which are described in the section below:

- location criteria,
- search area,
- development of a list of potential sites,
- data collection for potential sites,
- field visit for local verification and identification of potential sites,
- selection of best-ranked sites,
- preliminary environmental impact investigation, and
- final site selection.

### 4.5.1.1 LOCATION CRITERIA

The SWM Rules, 2016 provide the criteria for the location of a sanitary landfill (Section 4.1 of Part II). It should be verified if further criteria are specified by a regional regulatory agency (e.g., SPCB and PCC). “Guidelines for the Selection of Site for Landfilling” from the Central Pollution Control Board (CPCB) (Annexure 6) should also be referred. It also includes guidance for developing a site sensitivity index potential sites.

Pursuant to guidance in the SWM Rules, 2016 and based on good practices, the following criteria in Table 4.2 are suggested. Construction of sanitary landfills for municipal waste within restricted zones should be avoided at all costs.

**Table 4.1: Criteria for Identifying Suitable Land for Sanitary Landfill Sites**

| S.NO | PLACE   | MINIMUM SITING DISTANCE   |
|------|---|---|
| 1    | Coastal regulation, wetland, critical habitat areas, sensitive eco-fragile areas, and flood plains as recorded for the last 100 years | Sanitary landfill site not permitted within these identified areas                |
| 2    | Rivers  | 100 metres (m) away from the flood plain  |
| 3    | Pond, lakes, water bodies   | 200 m   |
| 3    | Non-meandering water channel (canal, drainage, etc.)  | 30 m  |
| 4    | Highway or railway line, water supply wells   | 500 m from center line  |
| 5    | Habitation  | All landfill facilities: 500 m  |
| 6    | Earthquake zone   | 500 m from fault line fracture*   |
| 7    | Flood prone area  | Sanitary landfill site not permitted  |
| 8    | Water table (highest level)   | The bottom liner of the landfill should be above 2 m from the highest water table |
| 9    | Airport   | 20 km**   |

\* The urban local bodies (ULBs) located in seismic zone 4 and zone 5 should consult the seismic fault map before finalising the site for the sanitary landfill. They should also ensure that when the sanitary landfill is designed, the seismic factors are taken into consideration in determining the stability of the landfill structure.

\*\* In a special case, a landfill site may be set up within 10–20 km away from the airport or airbase if there is no objection certificate from the civil aviation authority or air force as the case may be.

### 4.5.1.2 SEARCH AREA

In an event where potential sites for MSW landfill facilities are not demarcated by the Town Planning Department, the ULB should delineate an appropriate search area, which should ideally be located within the municipal boundary. The extent of the search area is usually governed by the economics of waste transportation (Section 2.3.12 of Part II). The Town Planning Department and other concerned authorities should be consulted while demarcating the search area.

Search areas help in identifying potential sites for sanitary landfill by delineating waste generating unit as a centre

### 4.5.1.3 DEVELOPMENT OF A LIST OF POTENTIAL SITES

After demarcating the search area and considering the various locational criteria, areas having potential for site development should be identified while mapping. A road map may be used to show the potential sites that satisfy the locational criteria.

In areas where land is scarce, degraded sites such as abandoned quarry sites or old waste dumpsites can be considered. Special design measures are required for such sites.

The values in Table 4.3 can be used as rough guidance or estimation for the required sanitary landfill area including the related infrastructure.

Potential sites for sanitary landfill development should also conform to the long-term land use goals

**Table 4.2: Rough Guidance for Sanitary Landfill Sizes<sup>2</sup>**

| WASTE QUANTITY (TONNES PER DESIGN LIFE OF LANDFILL) |          | REQUIRED SITE AREA (HA) |
|---|----------|-------------------------|
| in million  | in lakhs |                         |
| < 1.0   | < 10     | 15-20                   |
| 1.0 - 2.0   | 10 - 20  | 20-30                   |
| 2.0 - 3.0   | 20 - 30  | 30-40                   |
| > 3.0   | > 30     | > 40                    |

### 4.5.1.4 DATA COLLECTION FOR POTENTIAL SITES

In order to identify the suitability of potential landfill sites in the search area, a map screening will be conducted by applying more detailed selection criteria and analysing site specific data. The objective is to exclude unsuitable areas which do not meet specified criteria. Maps and other available sources of information as tabulated in Table 4.4 may be used to support this secondary selection process:

Map screening results in generating plans that indicate areas to be considered and areas that do not meet site selection criteria. Considered areas will require further investigations before they are finalised

**Table 4.3: Data Collection and Sources<sup>3</sup>**

| S. NO. | DATA             | INFORMATION   | SOURCES                                       |
|--------|------------------|---|---|
| 1      | Topographic maps | The topography indicates low and high areas, natural surface water drainage patterns, streams, and rivers as well as roads, railways, and location of airports.                         | Survey of India                               |
| 2      | Soil maps        | These maps, primarily meant for agricultural use, show the types of soil near the surface.  | Indian Agricultural Research Institute (IARI) |
| 3      | Land use plans   | These plans are useful in delineating areas with definite zoning restrictions. There may be restrictions on the use of agricultural land or forest land for sanitary landfill purposes. | Town planning authority or municipality.      |

<sup>2</sup> Developed by the Expert Committee for revision of MSWM manual (2013-15)

<sup>3</sup> Ibid.

**Table 4.4: Data Collection and Sources [contd.]**

| S. NO. | DATA   | INFORMATION   | SOURCES   |
|--------|--|---|---|
| 4      | Water use plans                                    | The plans indicating the following items: <ul style="list-style-type: none"> <li>• private and public drinking water wells,</li> <li>• drinking water supply line(s),</li> <li>• wells located on surface water bodies and open wells, and</li> <li>• protection areas for drinking water.</li> </ul>   |   |
| 5      | Flood plain maps                                   | These maps are used to delineate areas that are within a 100 year flood plain.  | Irrigation Department   |
| 6      | Geologic maps                                      | These maps indicate geologic features and bedrock levels. They may be used to identify predominantly sandy or clayey areas.   | Geological Survey of India (GSI)                                |
| 7      | Aerial photographs, satellite imagery, Google maps | These can identify surface features such as small lakes, intermittent stream beds, and current land use, which may not have been identified in earlier map searches.  |   |
| 8      | Groundwater maps                                   | These maps indicate the depth to groundwater as well as regional groundwater flow patterns.   | Ground water boards or minor irrigation tube well corporations. |
| 9      | Rainfall data                                      | Precipitation data are used for designing the amount of possible leachate in cities.  | Indian Meteorological Department (IMD)                          |
| 10     | Wind rose maps                                     | Wind rose maps indicate the predominant wind direction in the area, based on which the location and orientation of the landfill footprint has to be decided.  | Indian Meteorological Department (IMD)                          |
| 11     | Seismic data                                       | The seismic activity of a region has to be considered in the design of sanitary landfills; landfills should ideally not be located in zone 5 seismic zone. However, in case of siting in zone 5, complete structural analysis should be carried out for designing the landfill and the design should include appropriate structural controls. | GSI or National Geophysical Research Institute (NGRI)           |
| 12     | Road maps  | Road maps indicate accessibility of the potential site.   |   |

Authorities and other relevant stakeholders may be asked to provide further information. The map screening excludes large unfavourable zones from further consideration and focuses on promising zones (e.g., areas away from settlements, hydro-geologically favourable etc.). All areas that do not meet specified criteria will be indicated in a constraint map.

The result of the map screening will be a plan (or plans) showing exclusionary (negative) areas as well as areas where further investigation (positive zones) is meaningful.

#### **4.5.1.5 FIELD VISIT FOR LOCAL VERIFICATION AND IDENTIFICATION OF POTENTIAL SITES**

A site reconnaissance will be conducted by a site visit as part of the preliminary data collection and map screening. All features observed in various maps will be confirmed.

The possible sites should be evaluated on the basis of the topographical conditions and the suitability of the landfill site, namely:

- a) sufficient land size;
- b) flat area with low inclination;
- c) connection to highways and conditions of the access roads;
- d) flooding during monsoons;
- e) land use and soil type;
- f) depth to groundwater table (as observed in open wells or bore wells)
- g) information on the sub-ground from clay, stone, or sand pits;
- h) crossing of electrical lines; and
- i) actual settlement patterns (eventual new or informal settlements).

#### **4.5.1.6 SELECTION OF BEST RANKED SITES**

CPCB, in 2003, developed the guidelines for selection of site for landfilling. These guidelines helped in the selection of most appropriate sites based on a Site Sensitivity Index. Once these sites are identified, they can be ranked on the basis of a defined criteria for the preliminary environmental impact investigation and final site selection as detailed in the following sections (Annexure 6).

#### **4.5.1.7 PRELIMINARY ENVIRONMENTAL IMPACT INVESTIGATION**

On the basis of the ranking scores of various sites, two or three sites may be chosen for a preliminary environmental impact investigation.

The impact of the sanitary landfill will be assessed and potentially quantified according to the national rules and the local conditions.

The preliminary environmental investigation should conclude in a rough comparison of assessed alternative sites among themselves as well as with the null alternative (i.e., if the project was not carried out) and suitability of the sites.

#### 4.5.1.8 FINAL SITE SELECTION

The final selection of the site from amongst the best-ranked alternatives should be done by comparing:

- a) environmental impact,
- b) social acceptance,
- c) land availability,
- d) transportation costs, and
- e) sanitary landfilling costs (site specific costs are to be considered).

Transportation costs may be compared on the basis of average hauling distance from the centre of the waste generating area.

In general, the material costs for liner system, leachate collection system, daily covers, final cover system, and all facilities are similar for all sites, considering normal site conditions (this shall change in areas of high water table, in hilly areas, and other peculiar issues). The main differences include:

- distance of the access road to regional road system;
- sub-ground conditions for earthworks to prepare the base of filling area; and
- distance to waste generators and waste processing facilities.

In-depth information on site parameters beyond those of the site selection process is necessary for the adequate design of the sanitary landfill.

#### 4.5.1.9 SITE INVESTIGATION AND SITE CHARACTERISATION

In-depth information on site parameters beyond those of the site selection process is necessary for the adequate design of the sanitary landfill at the selected site. A proper site investigation programme comprises:

- subsoil investigation,
- groundwater or hydrogeological investigation,
- surface water investigation,
- topographical investigation,
- environmental investigation, and
- traffic investigation.

Landfill design is dependent on all the above features. Hydrogeological and surface water investigations are critical for determining the detailed design of the landfill, and groundwater and surface water quality are



Transportation costs of waste to landfill plays a critical role in the selection of landfill site

to be monitored regularly during the active life and post-closure of the landfill to ensure fail-safe performance of the landfill.

### **Hydrogeological assessment:**

An assessment of the hydrogeological settings of a landfilling site is necessary to ensure that the site is conducive to the proposed design of the landfill, which should be in line with the specifications of the SWM Rules, 2016. Such an assessment should also be used to develop effective groundwater and leachate monitoring plans.

The hydrogeological assessment should include the following:

- obtaining samples to characterise soil or bedrock conditions,
- mapping groundwater depth and pressure within the site, and
- assessing baseline groundwater quality.

The identification of unsuitable soils that would not support the overburden of the proposed fill height is possible through such an analysis. An analysis of the groundwater flow and pressure should result in the determination of groundwater flow paths and inform leachate control mechanisms and contingency plans for failure of the leachate liner. Future monitoring of groundwater quality should be against a reference of baseline conditions.

Within the site, the location of the boreholes should be along the groundwater flow path, both hydraulically upgrade and downgrade to the footprint of the landfill, at least 5 meters away from the footprint of the landfill. In addition, groundwater monitoring as per specifications in the SWM Rules, 2016 is mandated. The design of the landfill should consider this hydrogeological information to prevent failure of containment.



#### **The objectives of a hydrogeological assessment are to:**

- (i) determine the physical, hydraulic, and chemical properties of the surface material and bedrock where appropriate;
- (ii) define groundwater flow characteristics and potential contaminant migration pathways;
- (iii) determine the structural integrity of the subgrade to support the landfill including its construction and any overlying facilities;
- (iv) determine the availability and suitability of the soil for cover and liner uses;
- (v) establish a groundwater monitoring network; and
- (vi) determine the feasibility of the contingency plans for contaminant control.

The hydrogeological investigation report for a site should include:

- i. ground surface contour plan showing surface watercourses and surface water bodies;
- ii. a contour plan of the water table, showing expected directions of groundwater movement;
- iii. piezometric contour plans for each aquifer, showing expected directions of groundwater movement;
- iv. a description of any aquifers and their interconnection, with generalised estimates of groundwater flow, and the potential flow paths and contaminant attenuation capabilities in the event leachate leaves the waste fill area in planned or unplanned quantities;
- v. a description of the background quality of the groundwater, and the existing and potential uses of the groundwater;
- vi. site plans and cross sections of the hydrogeological conditions;
- vii. the identification of any unstable soils or unstable bedrock; and
- viii. a water balance analysis considering precipitation, surface water drainage, infiltration, groundwater flow, exfiltration, and evapotranspiration.

#### Surface Water Assessment:

An assessment of the surface water conditions on the proposed landfill site and in the vicinity of the site (500 m) is required to ensure a stable landfill that is not impacted by or impacts surface water.



The design of the site should include a plan to control runoff from the site and to prevent erosion and sedimentation downstream due to on-site activities. A surface water monitoring plan should be established for identifying surface water quality impacts, both on-site and off-site. Contingency plans should be prepared to control surface water impacts resulting from the production of leachate in a quantity greater than expected or with a quality worse than expected.

The surface water assessment report should include:

- a general description of the surface water features of the area (watershed) in which the site is located and the surface water features in the vicinity of the site (flood plains, natural watercourses and water bodies, municipal drains, drainage paths, and boundaries); and
- a detailed surface water investigation to assess water quality, quantity, and habitat conditions (e.g., benthic community inventory) of the surface water features identified on the site, any surface water features flowing through the site, and any surface water features receiving discharge from the site, including:



- a. an interpretation of the results of the detailed surface water investigation including:
  - (i) plans showing all existing surface water features; and
  - (ii) a description of current surface water quality, and the existing and proposed surface water uses.
- b. a site drainage plan showing the drainage of surface water at the site before the site is established, during operation of the site, and following site closure;
- c. plans, specifications and descriptions of the design features, control facilities and operational procedures to isolate, contain, convey, control or treat the surface water, on and off site, prior to its discharge to the receiving watercourse(s). The plans, specifications and descriptions should consider both clean surface water, sources (off-site and on-site flows separated from landfill operations through control mechanisms like berms and ditches) and potentially contaminated storm water (on-site flows originating from landfill areas);
- d. the design and location of any surface water control facilities, such as berms, swales, ditches, control ponds or other facilities for the control of the quality and quantity of surface water from the site. The design should be sufficient to convey peak flow volumes from a 25 year design storm. However external storm water conveyance mechanisms should be able to transport peak flows from a 100 year design storm.

Life of a sanitary landfill comprises the following:

- Active period: 20–25 years
- Closure and post-closure period: 15 years more after active period

## 4.5.2 SANITARY LANDFILL DESIGN

### 4.5.2.1 DESIGN LIFE

The life of a sanitary landfill comprises of an active period and a closure and post-closure period. The active period may typically range from 20 to 25 years depending on the availability of land area. The closure and post-closure period, for which a sanitary landfill will be monitored and maintained, will be 15 years and more after the active period is completed.

### 4.5.2.2 SPECIFIC WASTE VOLUME: SANITARY LANDFILL CAPACITY AND AREA

A rough capacity needs assessment was already conducted as the first step of the site selection process. An in-depth capacity calculation will be the first step in the design process, taking into account the municipal solid waste management (MSWM) plan and computed waste amounts for the active period of the sanitary landfill.

Landfill volume estimates are necessary for planning and determining the dimensions of the new landfill

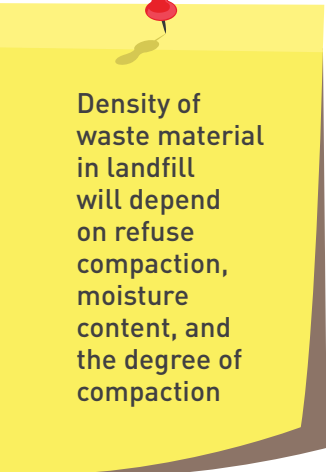

Density of waste material in landfill will depend on refuse compaction, moisture content, and the degree of compaction

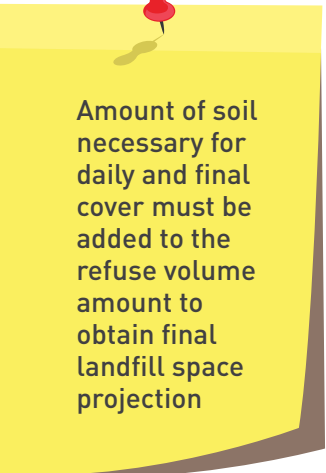

Amount of soil necessary for daily and final cover must be added to the refuse volume amount to obtain final landfill space projection



Planners and operators must carefully plan new facilities and optimise the design criteria that adhere to technical and environmental considerations

Based on the MSWM plan, the volume of waste in a sanitary landfill should be roughly calculated under the following assumptions:

- 1 tonne of waste is equivalent to 1 cubic metre ( $m^3$ ) of sanitary landfill volume. (In reality, the specific weight of waste in a sanitary landfill is  $0.8 \text{ t/m}^3$  during the first years and will increase after settlement over the time to  $1.2 \text{ t/m}^3$ .)
- Covering of waste will use about 10% more volume.

The total sanitary landfill area (for details, see next section) would be larger than the area required for the filling area to accommodate all infrastructure and support facilities as well as to allow the formation of a green belt around the sanitary landfill.

From an economical viewpoint, a small base area with a high sanitary landfill is preferable, because it reduces considerably the cost for the sealing systems, leachate collection system, and operational roads. The generation of leachate and the related costs will also decrease.

From a technical viewpoint, it is important to guarantee the runoff of rainwater. Therefore, minimum inclinations have to be maintained at the slopes. Every footprint of the disposal area of a landfill will have to maintain a certain minimum height to meet these inclination requirements. The height of the sanitary landfill is also constrained by the overburden pressure on the soil; it should be within acceptable limits.

From an environmental viewpoint, sanitary landfills with considerable heights can interfere with the landscape and cause visual disturbance. However, restricting the height would result in larger landfill footprints, requiring larger tracts of land. The larger the base of the landfill, the higher is the risk of leachate contamination of groundwater.

#### 4.5.2.3 SANITARY LANDFILL LAYOUT

As mentioned above, a sanitary landfill site comprises an area in which the waste will be filled and an additional area for support facilities. Within the area to be filled, usually only a part is under active disposal in a specific phase of operation. Figure 4.2 depicts a typical layout of a sanitary landfill.

**Figure 4.2: Typical Sanitary Landfill Layout with Facilities<sup>4</sup>**

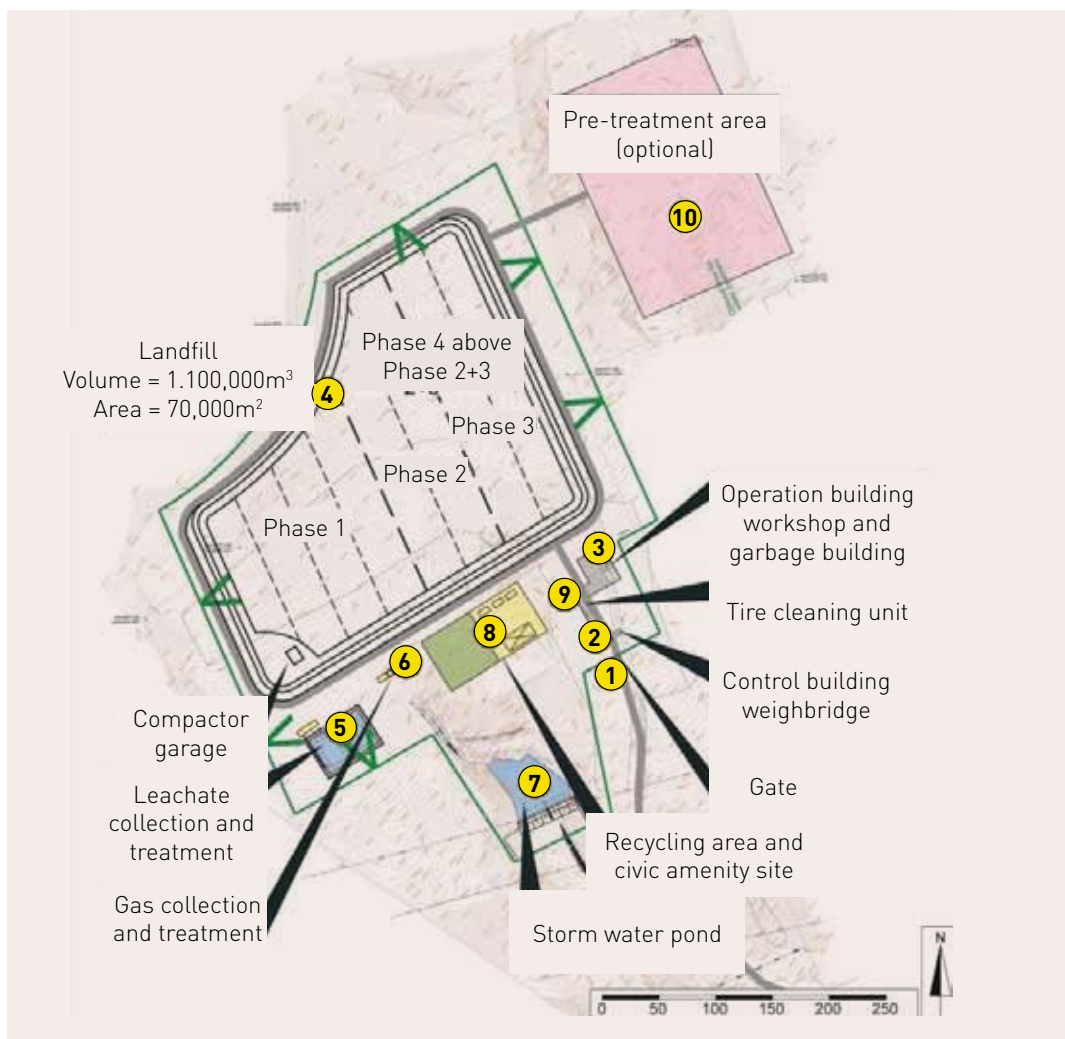

The following facilities must be located in the layout:

- access roads,
- equipment shelters,
- weighing scales,
- office space,
- location of waste inspection and transfer station (if used),
- temporary waste storage or disposal sites for special waste including domestic hazardous waste,
- areas to be used for waste processing (e.g., shredding),
- demarcation of the sanitary landfill areas and areas for stockpiling cover material and liner material,
- drainage facilities,
- location of sanitary landfill gas management facilities,

<sup>4</sup> Internal GIZ document for preparation of MSWM manual, GIZ-IGEP (2014).

- location of leachate treatment facilities,
- location of monitoring wells, and
- tyre cleaning unit.

For each sanitary landfill site, a layout has to be designed incorporating all these facilities. The layout will be governed by the shape of the sanitary landfill area.

The technical design specifications of sanitary landfill focus on efficient leachate management

#### 4.5.2.4 TECHNICAL DESIGN REQUIREMENTS

The design of the sanitary landfill focuses on optimised leachate management, as leachate is a main source of potential environmental pollution. It is important to minimise leachate generation and to avoid leachate being retained for a long time in the landfill body.

A landfill can be both above ground or partially below ground, based on the local hydro-geological situation and the availability of land. Where abandoned quarries are to be used as potential sanitary landfill sites, the landfill could be below ground, depending on the site situation.

Above ground landfills have the advantage that leachate flows by gravity according to the natural surface slope; leachate is collected in the main leachate pipe (header pipe), which is laid to extend beyond the footprint of the landfill. Leachate is pumped only from outside the footprint of the landfill.

If water table is not close to the ground surface, landfill base can be at a level below the ground, by excavation, to accommodate more waste per unit area of land.

However, below ground landfills are to be engineered and constructed appropriately to address the following issues:

- additional costs for excavation;
- the need to pump leachate during and beyond the active life of the landfill;
- environmental risks caused by nonfunctional pumps;
- potential for retention of leachate in the waste body;
- no possibility of pipe cleansing and controlling; and
- pumping cost for the leachate during the lifetime and the aftercare phase of the landfill.

Landfill constructed above ground faces minimal environmental impacts as leachate could be easily drained and collected for further treatment



### Sanitary Landfills in Hilly Regions

In hilly regions, it is usually not possible to find flat ground for sanitary landfills. Slope sanitary landfills and valley sanitary landfills have to adapt to the topographical conditions. In a slope sanitary landfill, waste is placed along the sides of existing hill slope. Control of inflowing water from hillside slopes is a critical factor in design of such sanitary landfills.

The design of these landfills needs additional site investigations and calculations. Furthermore, the sealing system has to adapt to the regional conditions. If adequate quantity of clay or fine soil is not available and the soil has permeability in excess of  $1 \times 10^{-7}$  cm/sec, use of additional layers of geosynthetics, geocomposites, or geosynthetic clay liners can be considered along with the locally available low permeability soil. The requirement of 90 cm clay (of best available quality locally) should be complied with, and the overall equivalence of such design of soil and additional layers will be checked and certified by geotechnical experts. Where required, soils amended with bentonite may be used to meet design specifications.



### Sanitary Landfills in Marshy Regions

Sanitary landfills should not be constructed in marshy areas; the local authority should access a regional landfill facility outside the marshy area.

## 4.5.2.5 BASE SEALING SYSTEM

The shape of the site should be adapted to the existing conditions with a minimum of fills and cuts. However, the mass which will be replaced by the sealing system has to be excavated.

For construction of the landfill geometry and the planned landfill embankments, soil material is required, which can be taken from the excavation part for the base sealing system. The remaining excavated soil should be stored for covering of waste during landfill operation.

The natural soil should be levelled and compacted to achieve 90% maximum dry density as obtained from Proctor compaction tests. This is sufficient to compact the overlying clay liner.

The base area has to have a sufficient slope to guarantee draining of leachate and storm water. Minimum inclinations are indicated in Table 4.5.

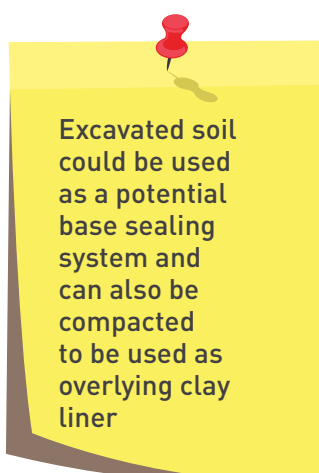

Excavated soil could be used as a potential base sealing system and can also be compacted to be used as overlying clay liner

**Table 4.4: Minimum Slopes Inside the Sanitary Landfill<sup>5</sup>**

| AREA                    | MINIMUM INCLINATION                                  |
|-------------------------|--|
| Base sealing            | 3 % for leachate pipes, roof profile                 |
| Main leachate pipe      | 1.0 %  |
| Secondary leachate pipe | 3.0 %  |
| Final slopes            | Not steeper than 1V: 4H and not flatter than 1V: 20H |

The composition of the base sealing system has to be in compliance with SWM Rules, 2016 and should consist of the following:

- **Mineral sealing liner:** It comprises three layers of clay or equivalent amended soil, at least 30 centimetres (cm) thickness each. In case adequate clay is not found in the vicinity, amended soil mixed with bentonite can be used. The permeability of the mineral sealing must be less than  $k_f \leq 1 \times 10^{-7}$  cm per second (cm/s).
- **Geosynthetic clay liner:** In hilly regions, the mineral part of the sealing system can be reinforced by a geosynthetic clay liner (see box below), if clay or natural soil for bentonite mixture is not available in sufficient quantity at an acceptable transportation distance.
- **High-density polyethylene geomembrane:** The high-density polyethylene (HDPE) geomembrane should have a standardised thickness of 1.5 millimeter (mm). Only HDPE geomembranes that comply with the requirements of American Society for Testing and Materials (ASTM) or corresponding standards should be used.
- **Protection layer:** A protection layer (of silty soil) should be 20–30 cm thick or, alternatively, a protection layer (geotextile) should be 400 grams per square meter ( $\text{g}/\text{m}^2$ ) for bottom liner and 200  $\text{g}/\text{m}^2$  for top cover, depending on the landfill height. If the planned height (height + depth) of the landfill is more than 20 m, geotextile should be 800  $\text{g}/\text{m}^2$ .
- **Leachate drainage layer:** A leachate drainage layer should be 30 cm thick made of filter gravel, ensuring a permeability greater than 10-2 cm/sec.

**Figure 4.3: Base Liner<sup>6</sup>**

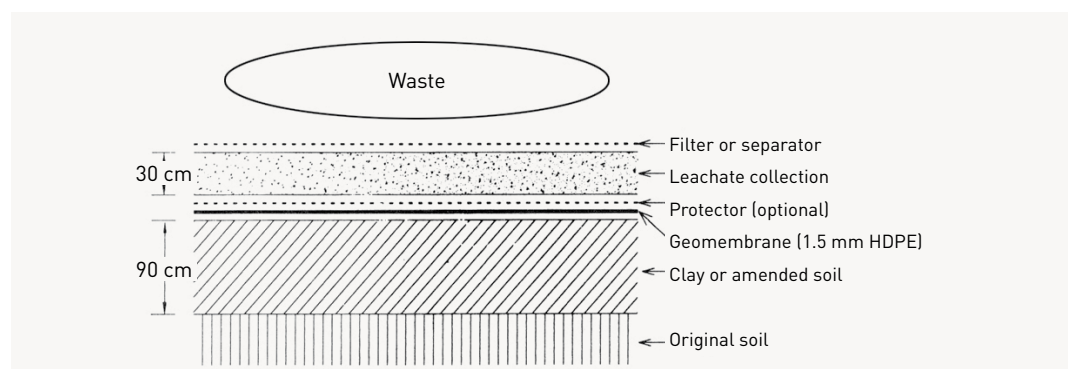

5 Developed by the Expert Committee for revision of MSWM manual (2013-15)

6 Guidelines and Check-list for evaluation of MSW Landfills proposals with Information on existing landfills, CPCB (2008). Available at: [http://cpcb.nic.in/upload/NewItems/NewItem\\_133\\_MSWM-REPORT.pdf](http://cpcb.nic.in/upload/NewItems/NewItem_133_MSWM-REPORT.pdf)



### Use of Geosynthetic Clay Liner for Municipal Solid Waste Landfill

Geosynthetic clay liner (GCL) is engineered to provide an impermeable barrier and can supplement the usage of a 90 cm thick mineral layer (clay) in the landfill base and cover. It consists of bentonite clay bonded to a layer or layers of geosynthetics.

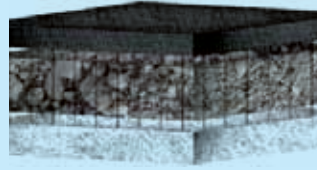

Bentonite (sodium montmorillonite) is volcanic clay used in a number of applications including GCL. In India, calcium bentonite, which has attributes similar to sodium bentonite, is commonly used.

GCL is typically bentonite sandwiched between geotextiles. It may be further reinforced by an additional layer of high-density polyethylene (HDPE) liner.

## 4.5.2.6 LANDFILL PHASING

The excavation of the landfill base should be phased in accordance with a predetermined phasing plan. To minimise damage to the landfill base layers, ensure continued integrity of base layers over the lifetime of the landfill, and minimise potential rainfall infiltration. The extent of each phase is designed so that the proposed waste fill volume (based on extent of base and waste fill contours) should be large enough for at least 1 year. Figure 4.4 shows indicative phasing schemes; depending on site conditions, either of the approaches may be followed. Phasing the landfill should be a site-specific decision, the below schemes are only indicative in nature.

Figure 4.4: a and b: Longitudinal Section Profile of Landfill Phasing (Not to Scale)<sup>7</sup>

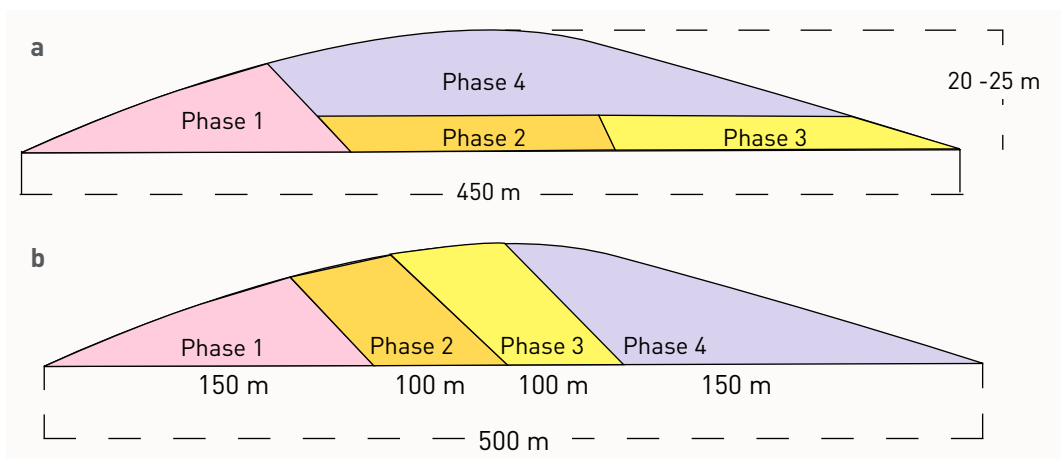

It should be noted that phase base for phase 2 shall be excavated and prepared 6 months before the final contours of phase 1 are reached. Typically, at least 6 months is required for base preparation for each phase. In year 1, phase 1 is considered the active phase and phase 2

7 Developed by the Expert Committee for revision of MSWM manual (2013-15)

as the phase under preparation. Phase 3 is to be excavated and base prepared only when 6 months of landfill capacity is left for phase 2.

The phases of the landfill, which include the edge of the landfill, have certain specific construction needs:

- (i) The base clay liner should be integrated with the clay barrier layer on the top cover.
- (ii) A granular blanket layer, which is an extension to the drainage layer of the leachate collection system (LCS) along the side slopes of the base, should be prepared. This granular blanket layer is required to prevent the entry of any rainfall runoff into the waste layers from the periphery of the landfill.
- (iii) The geotextile and HDPE liner should be tucked into the trench along the periphery of the landfill until the top cover is built to maintain stability and integrity of the liner as illustrated in Figure 4.5. Once the top cover is placed, the HDPE liner will remain in the trench, but the geotextile will be turned in and taken below the gravel layer of the gas venting layer.

**Figure 4.5: Liner Placement at the Edges of the Landfill<sup>9</sup>**

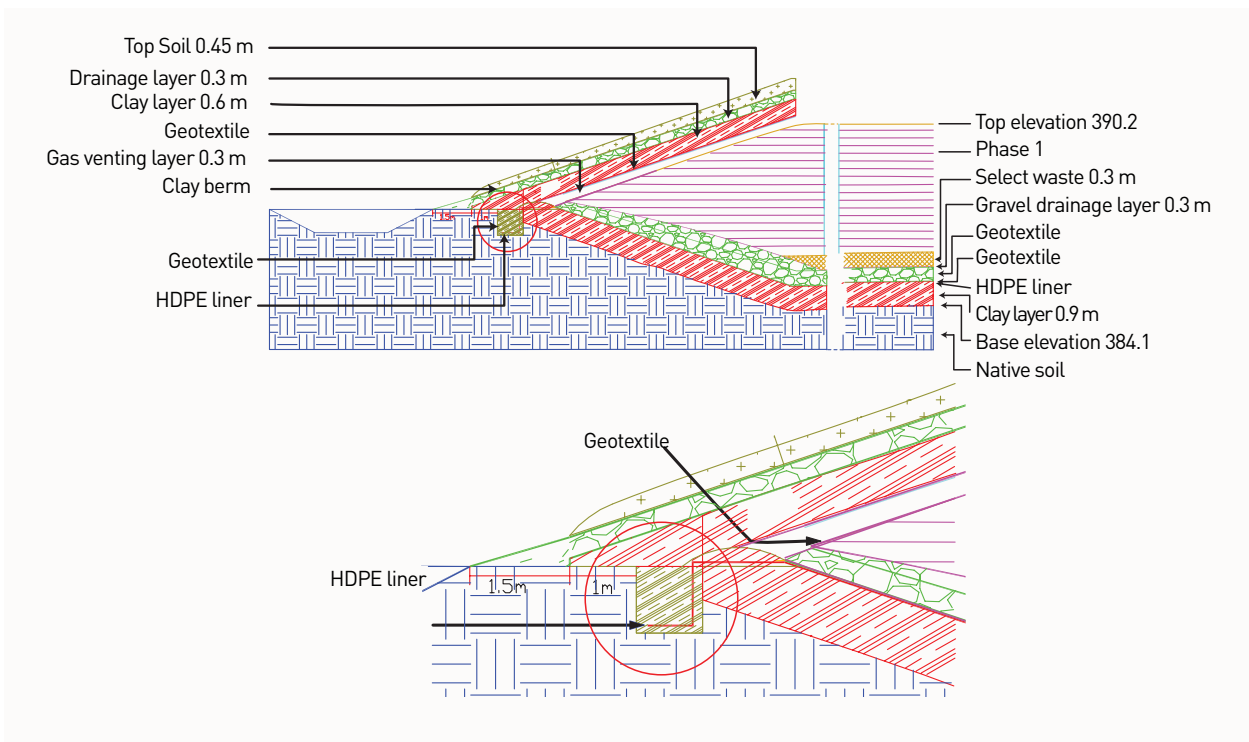

At the end of each phase, until the edge of the fill is reached, the HDPE and the geotextile of the liner are tucked into a trench, a temporary road ramp into the landfill is prepared beyond the trench, and a clay berm is constructed beyond this road to prevent runoff entering into the active phase or cell area.



The first layers of waste above the liner layers are always made up of select waste (30 cm). Select waste is defined as waste which has no sharp objects and hard debris in it and has a size range not exceeding 2 cm. The side slopes of the base have an extra layer of granular soil to prevent infiltration of any water into the waste. This layer acts as a granular drainage blanket and drains any water into the leachate collection layer.

Once the top fill contours are reached during any phase, corresponding portion of the top cover layers is also laid.

#### 4.5.2.7 LEACHATE MANAGEMENT

One of the most important objectives of a successful landfill management system is to avoid leachate generation as far as possible and to efficiently drain the leachate contained in the waste body and from other contaminated areas. As per the SWM Rules, organic and hazardous wastes should be diverted away from the landfill.

##### 4.5.2.7.1 Leachate Generation

The principal sources of leachate include:

- (i) moisture content of waste entering the landfill,
- (ii) infiltration from direct precipitation on the waste surface,
- (iii) sealed areas of landfill which are only partially covered with waste, and
- (iv) surface water flow onto the active face of the landfill.



To minimize the generation of leachate, the system should be designed in a way that only filled areas and currently operated areas are connected to the leachate collection system. The other sections should be connected to storm water ditches by using a storm water bypass system. Therefore, the sealed landfill area should be divided into strips of several filling sections.

Leachate generation amount should be estimated based on runoff coefficient and other data for efficient planning of leachate treatment system

##### 4.5.2.7.2 Leachate Collection

While designing the leachate collection system (LCS), it should be remembered that (i) a huge load would sit on top of this system and (ii) the system has to be operational for at least 15 years after final closure of the sanitary landfill. The base sealing system of the landfill should have a roof profile with a slope to the side or embankment. The leachate from the waste body will be collected in the drainage layer system and in the secondary drain pipes made of HDPE and will be directed to the main leachate pipes outside the waste body. The LCS consists of three main components: (i) a drainage layer, (ii) a series of collection pipes,

and (iii) a nonwoven geotextile (punched) separator layer as illustrated in Figure 4.6. The LCS layer is also to be laid along with the base, according to the phasing plan.

**Figure 4.6: Support of Leachate Pipes<sup>9</sup>**

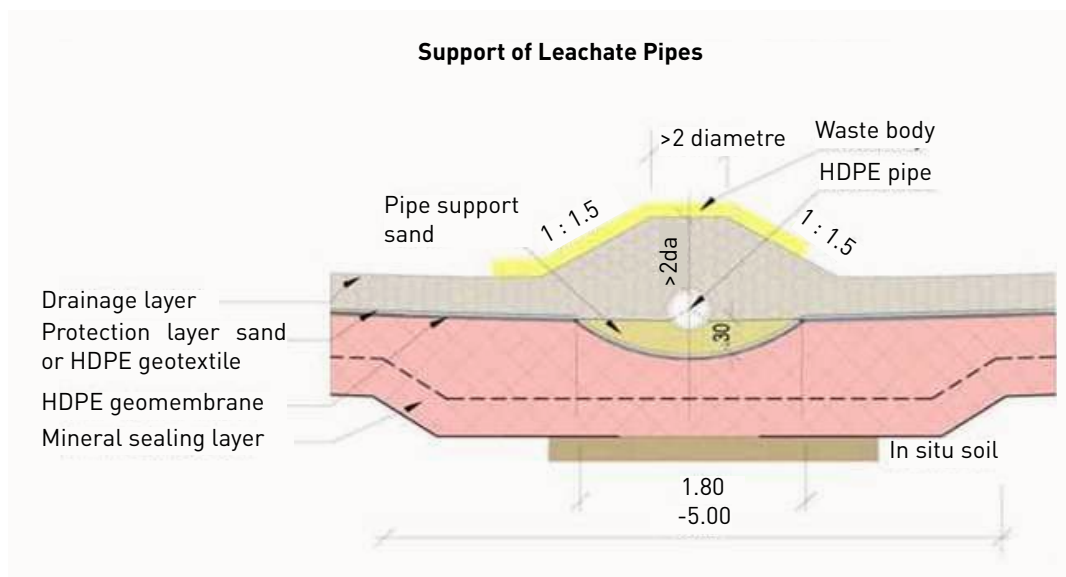

The leachate collection system and its components are to be laid over the HDPE geomembrane.

### Gravel Drainage Layer

The LCS layer consists of a 30 cm thick gravel drainage layer of 25–50 mm rounded gravel. The slope of the gravel drainage layer follows the minimum slopes required for the leachate collection system and inclines toward the collection point.

### LCS Pipes

Drain pipes are made of HDPE and slotted or holed on 2/3 of the pipe circumference. The diameter should be minimum 200 mm for secondary and 250 mm for main leachate pipes. The mentioned diameters should not undercut to allow controlling by remote camera systems. The wall thickness of pipes has to be calculated under the consideration of the overburden stress due to filling height of waste.

Perforated HDPE pipes are embedded in this gravel layer. The networks of HDPE pipes collect the leachate and are connected to a LCS sump(s). Leachate from the sump(s) is to be pumped to the proposed leachate treatment plan for disposal.

The specified distance between the secondary drain pipes should be around 40 m.

<sup>9</sup> Internal GIZ document for preparation of MSWM manual, GIZ-IGEP (2014).

At the end of the secondary leachate collection pipes, access windows for inspection and cleansing of pipes should be installed. The HDPE pipes are connected by welding.



#### Example Calculation: Estimation of Leachate Generation

|  |                    |
|--|--------------------|
| Average Total Precipitation in Delhi                                   | = 750 mm/year      |
| Plan area of operating phase   | = 10000 sq.m.      |
| Assuming 80% precipitation in 4 months (monsoon period)                | = 600 mm/4 months  |
| Peak leachate Quantity (thumb rule basis) = $(0.6 \times 10000) / 120$ | = 50 cu.m. per day |

### Geotextile Layer

Further protection from clogging in the LCS will be provided by a nonwoven geotextile installed above the entire stone drainage blanket. The geotextiles on top of the stone act as a separator layer between the drainage blanket and the solid waste and also provides additional filtering capacity to help maintain the high permeability of the underlying drainage layer.

At no time should vehicles be allowed to pass over the geotextile without a buffer layer in between.

The entire process of construction and arrangement of leachate collection system is illustrated in Figures 4.7–4.9. The leachate collection pipes could either rise along the side slopes of the landfill base as shown in Figure 4.9a, or through the liner as shown in Figure 4.9b. The leachate collection sumps, in some cases, are located within the foot print of the landfill as shown in Figure 4.9c. The actual design configuration should be according to the local site conditions and height and depth of the landfill.

**Figure 4.7: Placement of the High density Polyethylene Liner over the Clay Liner<sup>10</sup>**



<sup>10</sup> Developed by the Expert Committee for revision of MSWM manual (2013-15)

**Figure 4.8: Placement of the Gravel Drainage Layer and Geotextile over the Clay Liner<sup>11</sup>**

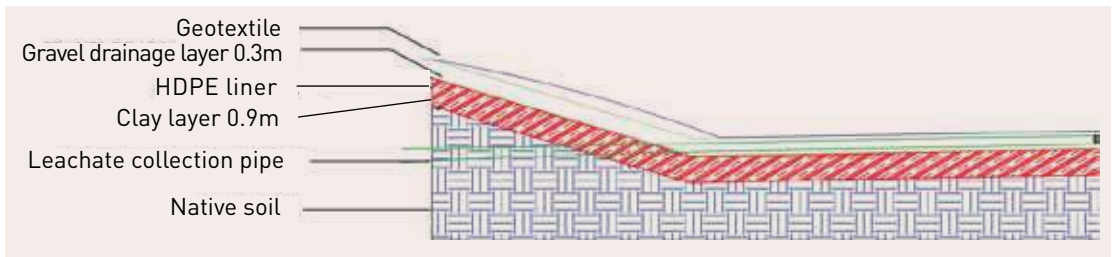

**Figure 4.9a: Leachate Collection Pipes Connected to a Sump (through the liner)<sup>12</sup>**

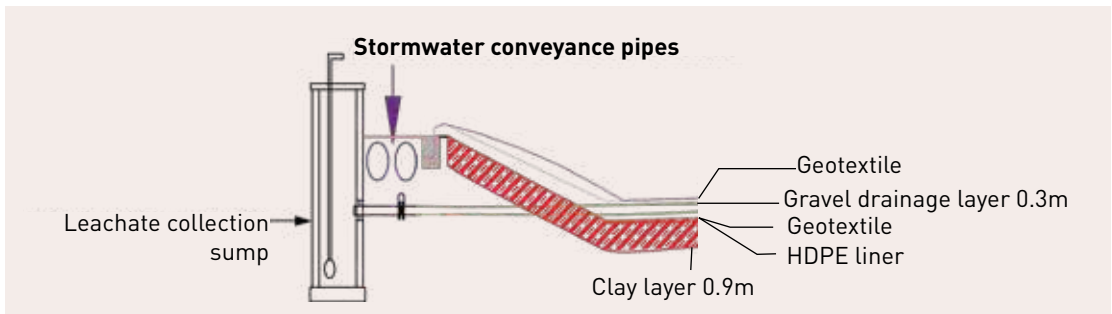

**Figure 4.9b: Leachate Collection Pipes Connected to a Sump (through a riser on the side slopes)**

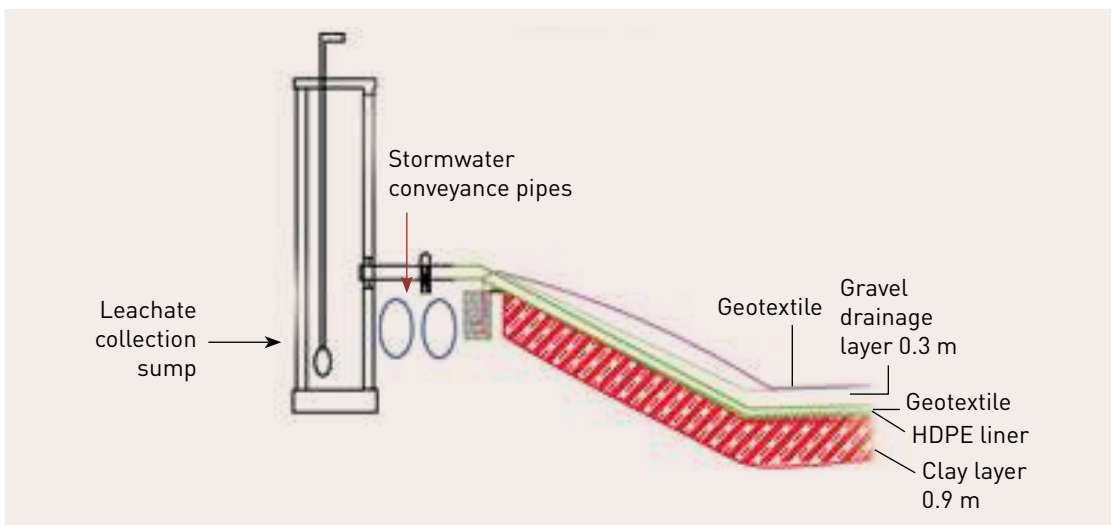

11 Ibid.

12 Ibid.

**Figure 4.9c: Leachate Collection Pipes Connected to a Sump (sump within the footprint of the landfill)<sup>13</sup>**

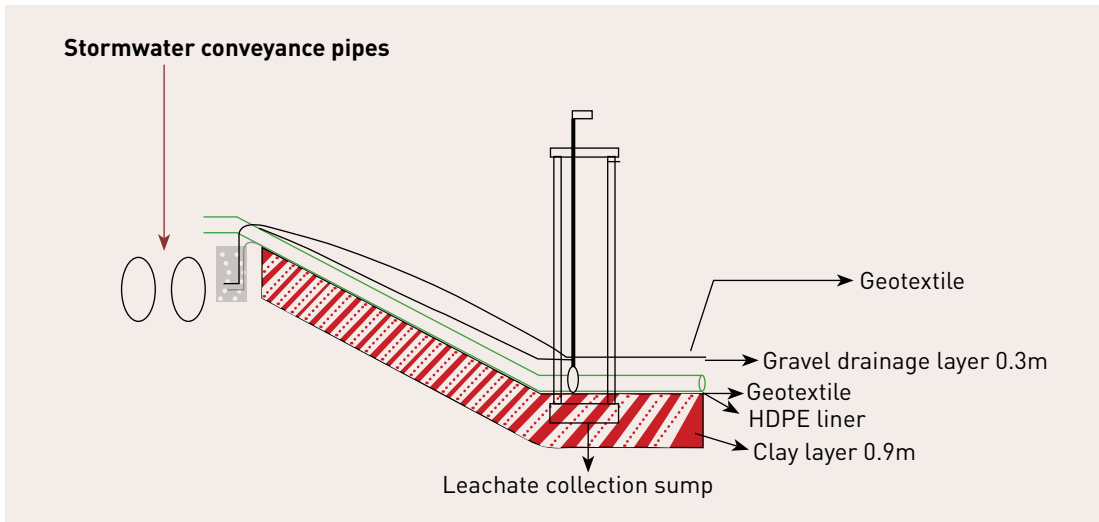

The primary criterion for design of the leachate collection system is that all leachate should be collected and removed from the landfill at a rate sufficient to prevent a hydraulic head greater than 12 inches from occurring at any point over the lining system. The system is designed to remove the accumulation of storm water resulting from a 25-year, 24-hour storm, within 72 hours. Other design criteria include the following:

- Bottom of the leak detection layer and the leachate collection layer is sloped at a minimum 2%;
- Granular drainage layer is 1 foot thick with hydraulic conductivity of  $>1 \times 10^{-2}$  cm/s;
- The system must be designed to minimise clogging;
- The system is located above the seasonally high water table;
- System must be designed to handle the runoff from a 25-year, 24-hour storm.

#### 4.5.2.7.3 Leachate Pond

The leachate pond is a basin to retain and pre-treat leachate within several days. The pond allows sedimentation and biological stabilisation. Organic pollutants in the leachate are removed by microorganisms and by sedimentation processes. At the bottom of the pond, a mixture of mud and water will be settled and pumped to the landfill when the pond is cleaned.

The leachate pond should have two basins to achieve an optimal leachate management (Figure 4.10). Division of the leachate pond into two individual ponds will make it possible to clean the ponds and their associated pipes. One basin might be cleaned or repaired while

Leachate ponds help in sedimentation and biological stabilisation of leachate.

<sup>13</sup> Ibid.

the other stays operational. The pond will be a necessary base for all further treatment methods.

**Figure 4.10: Sealed Leachate Pond with Two Basins<sup>14</sup>**



Leachate could be

- discharged to waste water treatment system for co-treatment
- recirculated through the landfill
- treated using biological or physicochemical treatment
- evaporated in solar ponds

#### 4.5.2.7.4 Leachate Treatment

The type of treatment facilities to be used depends on the leachate characteristics and volume. Typically, treatment may be required (prior to discharge) to reduce the concentration of biodegradable and non-biodegradable organic material, specific hazardous constituents, ammonia and nitrate ions, sulfides, odorous compounds, and suspended solids.

The appropriate leachate treatment scheme would significantly depend on the organic content of the disposed waste. As per the SWM Rules, 2016, biodegradables should not be disposed in landfills. However, due to absence of processing facilities or the presence of organic content in rejects from processing facilities, landfills are not devoid of biodegradable material. The concentrations of these biodegradables would vary from landfill to landfill. Laboratory tests should be conducted to ascertain the quality and constituents of leachate in every landfill.

Based on the chemical characteristics of the leachate, treatment may include biological processes (e.g., aeration, activated sludge, nitrification or denitrification); chemical processes (e.g., oxidation, neutralisation); and physical processes (e.g., air stripping, activated adsorption, ultra filtration, etc.).

A leachate treatment facility should be designed by an experienced landfill engineer in cooperation with a waste water treatment specialist

<sup>14</sup> Taken from GIZ-ASEM project (2008).

Leachate treatment of large landfills require substantial area of land as well as investment. In case of smaller landfills, a more practical way could be to take the leachate to the nearest sewage treatment plant (STP). In many countries, co-treatment of leachate with sewage is practiced successfully. However, depending on the age of the waste, the chemical composition of the leachate varies and results in significant loads of different constituents at different times on the STP. The biochemical oxygen demand (BOD) and nitrogen load are critical and should be considered before assessing whether an existing STP can handle incoming leachate.

### Evaporation of Leachate:

One of the simple techniques used to manage leachate is to spray it in lined leachate ponds and allow the leachate to evaporate. Additionally, the leachate can be irrigated on the slopes of the pond to intensify the evaporation rate as shown in Figure 4.11.

**Figure 4.11: Irrigation of Leachate on the Slopes of the Pond.<sup>15</sup>**



Such ponds have to be covered with geomembranes during high rainfall periods. The leachate is exposed during the dry and hot months to allow evaporation. Odour control has to be exercised at such ponds. However, spraying should not be done during high wind velocities to check air pollution.

The treated leachate may be discharged to surface water bodies, after ascertaining the quality as per the norms for discharge to inland water systems specified in the SWM Rules, 2016.

<sup>15</sup> Internal GIZ document – Integrated Solid Waste Facility Manual for the operation of the sanitary landfill, GIZ-IGEP (2015).

#### 4.5.2.8 WASTE PLACEMENT

A 30 cm thick layer of select waste will be placed on the geotextile as and when the laying is completed. It is preferable that this select layer of waste be left without compaction. In order to dump subsequent layers of waste, soil should be pushed gently by a light dozer to make a path. Dumping of soil directly on the membrane should be avoided as much as possible. One or two main routes of soil should be created for use by heavier equipment for soil moving with 60–90 cm. Damage to the membrane due to traffic can be severe and undetectable and hence should be avoided at all times. The first lift of waste should be spread and compacted with light vehicles. It is preferable not to compact the first foot of waste. No bulky items should be dumped in the first lift.

#### 4.5.2.9 SURFACE SEALING SYSTEM

The following layers are part of the surface sealing as illustrated in Figure 4.12:

- **Gas drainage layer:** The layer should be a 30 cm thick granular gas drainage layer formed by crushed gravel or crushed demolition waste to facilitate gas collection.
- **Mineral clay layer:** The mineral material (60 cm) should be clay or amended soil and should satisfy permeability requirements of  $k = 10$  cm/s. If the available soil has higher permeability, additional layers of 1.5 mm HDPE can be installed over 60 cm thick soil layer. The overall equivalence of such design of soil plus additional layers has to be checked and certified by geotechnical experts. 1.5 mm HDPE liner should be covered with a 20 cm protection layer or geotextile.
- **Water drainage layer:** The water drainage layer should be 30 cm thick formed by crushed gravel. The gravel layer should be covered by a geotextile or alternate separator to prevent clogging of the drainage layer by the overlying soil. An alternative is a drainage mat (Secudrain), but it is more costly.
- **Vegetative soil layer:** The top layer should be 45 cm thick vegetative soil.



Figure 4.12: Surface Liner System<sup>16</sup>

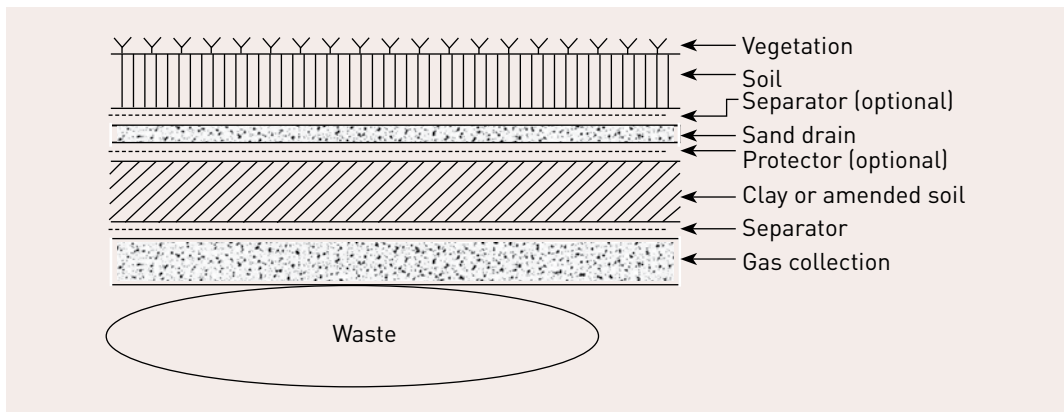

## 4.5.2.10 INFRASTRUCTURE FOR SANITARY LANDFILL

### 4.5.2.10.1 Road Construction

#### Access Road

The access road to a sanitary landfill should be constructed in accordance with the following design parameters:

- 6.5 m width of roadways with two lines, and
- 20 cm stabilised sub-foundation layer, anti-freeze layer if located in frost-prone areas.

Roads within the site should have:

- 3.0 m width of roadways, and
- 40–50 cm foundation layer made of broken material or demolition waste.

### 4.5.2.10.2 Equipment and Resources

The Sanitary landfill should be supplied with:

- water supply,
- energy,
- communication,
- sewage system,
- external lighting, and
- fire fighting (external).

A sanitary landfill should provide basic infrastructure and resources like roads, water supply, energy, etc.

16 Guidelines and Check-list for evaluation of MSW Landfills proposals with Information on existing landfills, CPCB, 2008. Available at: [http://cpcb.nic.in/upload/NewItems/NewItem\\_133\\_MSU-REPORT.pdf](http://cpcb.nic.in/upload/NewItems/NewItem_133_MSU-REPORT.pdf)

#### 4.5.2.10.3 Waste Inspection Area or Emergency Area

The incoming waste has to be controlled within the entrance area. This area will also be used for parking during bad weather conditions while waste disposal on the landfill site is not possible.

#### 4.5.2.10.4 Security and Fencing

Site security is among the most important considerations in landfills. The site should be secured to implement a good standard of service. In order to achieve this, the site has to be peripherally fenced and access to the landfill should be limited to one entrance gate, which should be blocked when the site is unattended. The fence will also keep children, unwanted or unorganised scavengers, cattle, and other animals out of the site. It will also protect litter to be blown out of the landfill site.

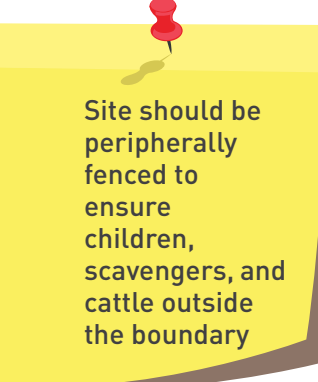

Site should be peripherally fenced to ensure children, scavengers, and cattle outside the boundary

#### 4.5.2.10.5 Tyre Cleaning Unit

The tyre cleaning unit consists of concrete and a removable horizontal steel grit. The water of the tyre cleaning unit will be discharged by a mobile pump to the leachate collection system. The mud will be excavated by a loader and disposed of at the landfill.

#### 4.5.2.10.6 Sanitary Landfill Buildings

##### Weighbridge and Control Building

The control building should be next to the main entrance gate of the landfill and should have electronic installations inside for control of the weighbridge. The area of the control building should be about 25 m<sup>2</sup>. The weighbridge should be adjacent to the control building.

##### Administration Building

The administration building should include manager's office, offices for manager's secretary and assistants, meeting room, cafeteria, kitchen, toilets and showers, dressing room, resting room and storage.

##### Garage and Workshop

The garage is needed to shelter and to repair all mechanical equipment in the landfill (except landfill compactor and bulldozer). The workshop or repair-centre in the garage should be a completely independent unit. Except for the costly or composite parts, the depots of the garage should carry spare parts of vehicles, compactors, and other equipment, according to the service contract signed by the suppliers of the equipment and the municipality.

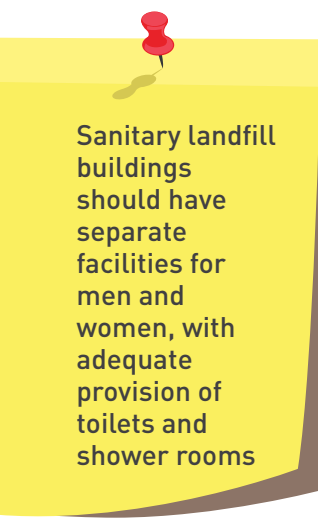

Sanitary landfill buildings should have separate facilities for men and women, with adequate provision of toilets and shower rooms

## Compactor Shed

The compactor shed should be located next to the disposal area. This building serves as a protection for the landfill compactor and bulldozer from bad weather conditions while they are not in operation.

An example of design and calculations for a sanitary landfill are given in Annexure 7.

### 4.5.3 CONSTRUCTION OF A SANITARY LANDFILL

The construction of a sanitary landfill (Figure 4.13) is a specialised activity that requires continuous coordination between the design engineer and the construction agency. Supervision of construction activity and third party evaluation of construction quality and adherence to design is required.

**Figure 4.13: Sanitary Landfill under Construction<sup>17</sup>**



#### 4.5.3.1 SUPERVISION OF CONSTRUCTION WORKS

The construction of a sanitary landfill should be supervised by an independent engineer on behalf of the municipality or the employer. The main tasks are:

- approval of the drawings and the final design;
- quality assurance of all operations related to the landfill and their compliance with the SWM Rules, 2016;
- time scheduling, steering, and coordination of the construction sites; and
- acceptance of the construction work and supply.

<sup>17</sup> Taken from GIZ-ASEM project (2008).

### 4.5.3.2 QUALITY ASSURANCE

#### Test Field

In order to ensure the sanctity of the liner system after sealing operations, a test field may be established (Figure 4.14), which is to be included as a part of the standard operating procedure for designing the landfill. The costs for establishing the test field should be included in the overall project costs.

Figure 4.14: Construction of Test Field<sup>18</sup>



The test field has to be constructed outside of the sealing areas and have to be retained and protected for the entire duration of construction to prove the sanctity of the liner. Within a test field, the suitability of all materials for sealing must be proved under actual conditions of the site. The results of these tests should be considered as the basis for the detailed design.

Construction of the test field should start on the surface with 3 layers of clay. A trial pit shall be installed in the test field for visual check of the quality of the compressed layers.

Three samples of each test field (investigation area) must be examined for the following laboratory tests:

- truck drive tests,
- determination of density,
- determination of deformation module,
- proctor density,
- water permeability, and
- water content.

<sup>18</sup> Taken from GIZ-ASEM project (2008).

All examinations required for each layer should be carried out by an independent engineer.

These results must be evaluated and documented including the following conclusions with regard to the design of the mineral sealing system:

- compacting methods,
- compacting equipment,
- number of compacting passes of roller,
- operation speed of compacting equipment, and
- thickness of compacted layers and those which are not compacted.

The test fields must be at least 20 m in length and the minimum width must be 2 machine widths. The ramps should be in the ratio of 1:10 and the embankments should be in the ratio of 1:5. Adequate care should be taken so that the distance of acceleration and deceleration with driving tracks is wide enough for the equipment to function properly if they were to be arranged alongside.

The test fields should be built in the bottom and embankment area of the landfill. They show the same slopes as the fields built later. After the mineral sealing material has been tested, the application of the other sealing compounds, protection layer, and drainage layer should be tested in the test field accordingly (Figure 4.15). This has to be done for the base sealing as well as for the surface sealing.

**Figure 4.15: Test Field with all Sealing Components<sup>19</sup>**



<sup>19</sup> Taken from GIZ-ASEM project (2008).

## Mineral Sealing Layer

For the sealing material as well as for the construction, the requirements are as follows:

- Selection of the grain size distribution of the mineral material should prevent micro substances from getting discharged (suffusion stability or dispersion stability) as well as from increasing the crack resistance.
- Soil containing coarse gravel and stones, wood, roots, and other impurities should not be applied. The digging locations provided for supply of the mineral material should be examined thoroughly.
- When the sealing material is introduced, it should be homogenous and show homogeneous water content.
- The water content must be higher than the optimum moisture content (OMC) determined by standard proctor test. Mineral sealing layers should not be constructed under bad weather conditions (rainfall).
- The top of the landfill surface bearing and of each completed layer of the mineral sealing system should be dewatered sufficiently. The required layer thickness, which should not exceed by more than 10 %, will be determined on the test field. Special attention should be paid to tight intermeshing (compound) of the layers built one on the other.
- If required, the mineral sealing material should be homogenized and crushed by a milling cutter.
- Compression with the sheepsfoot roller is of special importance because of its kneading and packing effect.
- The top layer surface of the sealing system should be flat and without driving tracks.
- After completion of each compacted layer, an acceptance test should be carried out before introducing the next layer or the placement work of the geotextiles.

## High-density Polyethylene Geomembrane

For constructing the layer, the following items have to be considered:

- supervision of the constructing and placing of the liner;
- a suitable firm placing the plastic liner;
- material requirements or tests;
- not less than 1.5 mm thick HDPE geomembrane (Figure 4.15);
- proof of stamp-pushing-force or ensuring plunger puncture;
- a manufacturer certificate, including product name and specifications;
- ensuring static proof; and
- proof of stability and resistance to sliding during building and final state.

A storage area should be prepared on site according to manufacturer.

For placing the plastic layer, among other things, the following issues should be regarded:

- Welding of the HDPE liner is only carried out if the temperature is  $> 5\text{ }^{\circ}\text{C}$ .
- On the surface of the HDPE liner, no water is allowed.
- The regulations of the manufacturer should be regarded (width of the overlapping, welding, etc.).
- The placed plastic liner has to be fixed (e.g., sandbags).
- It is forbidden to drive on the welded plastic liner with any equipment (only with the necessary equipment for welding).
- Every welding seam (Figure 4.16 and Figure 4.17) should be proofed (stability, density, thickness).

**Figure 4.16: Welding of HDPE Geomembrane<sup>20</sup>**



**Figure 4.17: Proof of welding seams<sup>21</sup>**



<sup>20</sup> Taken from GIZ-ASEM project (2008).

<sup>21</sup> Ibid.

## Geotextile

For protection of the HDPE liner, a geotextile should be applied when building the base sealing system. For the surface sealing system, the geotextiles are applied on the equalising and drainage layer.

The prescribed overlapping widths should adhere to each other. The geotextile should be laid in longitudinal roll direction with the inclination of the embankment. It is not allowed to drive on the webs laid, and equipment or machines should not be placed on the layers, under any circumstances. The web position must be secured by appropriate measures (i.e., sand bags) to prevent them from getting lifted.

### Material requirements or tests

Where geotextiles are used to provide significant puncture protection to geomembranes, the determination of an appropriate mass per unit area of the geotextile is critical. A factor of safety (Fs) of 3 or above against the puncture of geomembrane is considered a good practise.



#### Method for Calculating Geotextile<sup>22</sup>

$$FS = Pallow / Pact$$

Where:

FS = factor of safety against geomembrane puncture

Pallow = allowable pressure using different types of geotextile and site-specific conditions

Pact = actual pressure due to landfill contents

*Note: Indicative methods for calculation may be found at [http://www.landfilldesign.com/cgi-bin/gt\\_select.pl](http://www.landfilldesign.com/cgi-bin/gt_select.pl) and <http://www.geosynthetic-institute.org/papers/paper14.pdf>*

Based on real-world applications in India, the following geotextile specifications are found to be optimal, subject to further validation for site specific conditions:

- Weight of geotextile should be 800 g/m<sup>2</sup> (for height of waste: > 10m) and 400 g/m<sup>2</sup> (for height of waste: < 10m). Protection liner should be above the HDPE liner in the base sealing system.
- Protection layer should be 400 g/m<sup>2</sup> above the HDPE liner in case the HDPE liner is applied as surface sealing system.
- Separation liner should be 200 g/m<sup>2</sup> between the mineral drainage layer and the recultivation layer on the surface sealing system.

<sup>22</sup> Indicative methods for calculation may be found at: [http://www.landfilldesign.com/cgi-bin/gt\\_select.pl](http://www.landfilldesign.com/cgi-bin/gt_select.pl) and <http://www.geosynthetic-institute.org/papers/paper14.pdf>



As per the SWM Rules, 2016, the geomembrane needs to be 1.5 mm thick, 1,440 g/m<sup>2</sup> HDPE. In case a landfill is planned to have more than 20 m height, the weight of the geotextile may have to be increased as per the ground situation.

#### 4.5.3.3 DRAINAGE LAYER

For the base sealing system, the drainage layer is built on the protection layer. The drainage layer must comply with the following requirements:

- The chemical, physical, and mechanical stability of the material selected for the drainage layer must ensure that there is no negative effect on the drainage efficiency from the chemical and physical leachate characteristics and the mechanical load of the landfill body.
- For the drainage layer, washed material should be used and rounded grains preferred.
- Grain-size distribution of the material should be used for the drainage layer, with permeability greater than 10<sup>-2</sup> cm/sec.

#### 4.5.3.4 LEACHATE COLLECTION SYSTEM

The leachate collection system at the landfill base, embedded within the drainage layer, consists of the following, from top to bottom:

- **Nonwoven geotextile:** The system should have nonwoven geotextile (punched).
- **Granular leachate collection layer:** The granular leachate collection layer should be 300 mm thick, with granular diameter of 25–50 mm, overlying a 1.5 mm thick geomembrane or geosynthetic liner, and a 900 mm layer of compacted clay layer (Figure 4.8). The granular leachate collection layer must be designed such that the calculated hydraulic head of leachate above the composite liner is less than 0.3 m.
- **Construction and demolition products:** As per SWM Rules, 2016 (Schedule III, Part B), construction and demolition (C&D) products can be used for construction and operation of sanitary landfill.
- **High-density polyethylene leachate collection pipes:** The HDPE leachate collection pipes should convey the leachate collected by the granular leachate collection layer to the leachate sump, where the leachate can drain freely and be removed.

Leachate collection pipes must have adequate flow capacity to convey the leachate and adequate structural resistance to withstand the applied loads. In addition, since collection pipes are usually perforated to permit flow of leachate into the pipes, the size of the perforations must be large enough to accept the flow of leachate into the pipe without the buildup of head, and small enough to prevent gravel from entering the pipe. Figure 4.18 depicts proper welding practices to be followed while

welding HDPE pipes. Figure 4.19 depicts the proper placement of holes in the leachate pipes.

The leachate collection pipe and the granular material must be able to withstand the applied loads due to the overlying materials and equipment used at the facility throughout the entire design period. Three pipe failure mechanisms must be considered when designing a buried plastic pipe to be structurally stable under loads. These mechanisms are:

- wall crushing;
- wall buckling; and
- excessive ring deflection.

The following issues have to be considered while laying and attaching the HDPE pipes:

- permission for HDPE welding submitted by the construction firm;
- welding records for each welding seam made;
- pipes to be covered with filter gravel after each working day;
- visual check of position and slopes;
- check of the inside walls of the pipes and the welding seams with a movable video camera;
- pressure tests of the solid wall pipes of the leachate collector; and
- daily visual acceptance before covering and complete acceptance after submission of all build-in test results.

**Figure 4.18: Welding of Leachate Pipes<sup>23</sup>**



23 Taken from GIZ-ASEM project (2008).

**Figure 4.19: Proper Holed Leachate Pipes<sup>24</sup>**



#### **4.5.3.5 SLOPE STABILITY ASPECTS AND SEISMIC ASPECTS**

The stability of a landfill should be checked for the following cases:

- stability of excavated or filled slopes,
- stability of liner system along excavated or filled slopes,
- stability of temporary waste slopes constructed to their full height (usually at the end of a phase),
- stability of slopes of above-ground portion of completed landfills, and
- stability of cover systems in above-ground landfills.

The stability analysis should be conducted using the following soil mechanics methods depending on the shape of the failure surface:

- failure surface parallel to slope,
- wedge method of analysis,
- method of slices for circular failure surface, and
- special methods for stability of anchored geomembranes along slopes.

<sup>24</sup> Taken from GIZ-ASEM project (2008).

## 4.5.4 SANITARY LANDFILL OPERATION

### 4.5.4.1 GENERAL REQUIREMENTS

#### 4.5.4.1.1 Operation Manual

Before the operation of a sanitary landfill can be undertaken, it is important to develop the operating rules and methodologies, which has to be documented in an operation manual.

The operational manual should serve as a guidance document for the urban local body (ULB), private landfill operator, and personnel in the sanitary landfill sites to aid them in controlled landfill operations. It should also be part of any operation contract for private operators of the landfill site.

The operational manual should comprise the following main aspects:

- controlling and recording of landfilled waste;
- guide to use the remaining capacity in an optimised way with the support of filling plans and strategies;
- guide to undertake all operational duties required at the landfill site,
- basic health and safety measures; and
- maintenance of landfill facilities and landfill equipment if available.

#### 4.5.4.1.2 Employee Assignments and Responsibilities

The composition and number of the landfill staff have to be designed according to the size and requirements of the sanitary landfill. Table 4.6 suggests the following staff for the operation of a landfill site.

**Table 4.5: Provisional Staffing Table<sup>25</sup>**

| DEPARTMENT     | FUNCTIONS   |
|----------------|---|
| Management     | Landfill manager  |
| Administration | Controller<br>Weighbridge operator<br>Night watchmen                            |
| Operation      | Foreman<br>Machine drivers (wheel loader, dozer)<br>Spotter<br>Unskilled worker |
| Total          | Landfill staff  |

<sup>25</sup> Manual on Municipal Solid Waste Management (First Edition), Central Public Health and Environmental Engineering Organisation (CPHEEO), 2000.

### 4.5.4.1.3 Staff Responsibilities and Qualifications

The list in Table 4.7 indicates the major assignments and responsibilities of the various employees who work at the landfill. However, the table does not necessarily include all duties that may be required to safely and successfully operate the sanitary landfill. The list should be mandatory for private as well as municipal operators.

**Table 4.6: Staff Qualification<sup>26</sup>**

| <b>FUNCTIONS</b>                   | <b>RESPONSIBILITIES</b>  | <b>EDUCATION OR EXPERIENCES</b>   |
|------------------------------------|--|---|
| Landfill manager                   | <ul style="list-style-type: none"> <li>• Waste filling</li> <li>• Compliance with operation manual and filling plans</li> <li>• Daily (short-term) personnel planning</li> <li>• Supervision of the weighbridge operator or controller</li> <li>• Keeping of customers' contacts</li> <li>• Adherence of safety rules</li> </ul> | <ul style="list-style-type: none"> <li>• Civil engineering technician</li> <li>• Training in safety matters</li> <li>• Training in environmental issues</li> <li>• Knowledge of environmental legislation</li> </ul>        |
| Weighbridge operator or controller | <ul style="list-style-type: none"> <li>• Control and record of incoming waste</li> <li>• Operating the weighbridge</li> <li>• Directing vehicles to the disposal area</li> <li>• Visual monitoring of delivered waste other than municipal waste</li> </ul>  | <ul style="list-style-type: none"> <li>• Administration competencies</li> <li>• Training in environmental issues</li> <li>• Knowledge of environmental legislation</li> </ul>   |
| Night watchman                     | <ul style="list-style-type: none"> <li>• Site security especially during night time</li> </ul>   | <ul style="list-style-type: none"> <li>• Training in safety matters</li> </ul>  |
| Foreman                            | <ul style="list-style-type: none"> <li>• Waste filling procedure</li> <li>• Daily personal and equipment planning</li> <li>• Control of landfill compaction</li> <li>• Cell construction</li> <li>• Road construction and control of the condition of the roads</li> </ul>   | <ul style="list-style-type: none"> <li>• Trained foreman with long-time experience in construction works</li> <li>• Training in safety matters</li> </ul>   |
| Spotter                            | <ul style="list-style-type: none"> <li>• Traffic regulation in the filling area and organisation of waste disposal</li> <li>• Checking of unloaded waste</li> </ul>  | <ul style="list-style-type: none"> <li>• Special training in filling procedure</li> <li>• Training in distinction of different waste and of acceptable or unacceptable waste</li> <li>• Basic training in safety</li> </ul> |

<sup>26</sup> Manual on Municipal Solid Waste Management (First Edition), Central Public Health and Environmental Engineering Organisation (CPHEEO), 2000.

**Table 4.7: Staff Qualification [contd.]**

| FUNCTIONS         | RESPONSIBILITIES  | EDUCATION OR EXPERIENCES  |
|-------------------|---|---|
| Bulldozer drivers | <ul style="list-style-type: none"> <li>• Filling and the compaction of waste in the landfill</li> <li>• Waste unloading organisation together with the spotters</li> <li>• Daily inspection and maintenance checks of machinery</li> <li>• Cleaning machines</li> </ul> | <ul style="list-style-type: none"> <li>• Vehicle driver’s license</li> <li>• Special training on compactor and bulldozer</li> <li>• Basic training in safety</li> </ul> |

#### **4.5.4.1.4 Hours of Opening and Operation**

The days and hours of opening of the landfill site for public deliverers should be determined by the municipality and the operator of the sanitary landfill. The opening hours should be published on a sign board and in the related newspapers and websites.

#### **4.5.4.1.5 Site Notice Board**

A notice board has to be installed at the entrance to the site, which should specify the following:

- (i) the name and contact information for the sanitary landfill site, including the telephone number;
- (ii) opening days and times; and
- (iii) site rules and regulations, e.g., “No Smoking,” “Wear Safety Clothes,” etc.

#### **4.5.4.1.6 Site Security**

The security has to ensure that the site is safe and secure at all times. The security staff will provide after-hours security patrol around the landfill site. The security staff will also be responsible for operating and maintaining the following:

- landfill entrance security;
- safeguarding the on-site vehicles and equipments;
- reporting any security-related incidents immediately to the landfill manager; and
- completing the daily site security check list for the entire facility.



#### **4.5.4.2 WASTE RECEPTION AND CONTROL OF INCOMING WASTE**

All deliveries from collection vehicles of the municipality and from private service providers should be documented by checking the (registered) license plate number, the respective labelling on the vehicles, or the respective license. Corresponding lists with the license plate numbers have to be compiled beforehand by the landfill supervisor to help the weighbridge operator identify the vehicles.

Waste deliveries from licensed commercial and industrial deliverers and private deliverers within the municipality are to be identified by checking the identity card of the driver as well as the license plate number. In case the presented documents do not fulfil the requirements of the waste permission, the deliverer has to be rejected. A rejection has to be documented in the operation diary.

A visual inspection has to be carried out in case of questionable origin or unclear waste type by examining the:

- appearance;
- consistency and composition;
- colour;
- smell.

If the visual inspection indicates noncompliance with the SWM Rules, 2016, the consignment has to be rejected. This process has to be documented in the operation diary.

##### **4.5.4.2.1 Execution of the Weighing Process**

The following data has to be recorded:

- license plate number;
- name of the corporation (in case of regional facilities);
- ward from which waste is collected;
- name of the weighbridge operator;
- gross and net weight of the vehicle; and
- date and time of entrance.

The deliverer has to follow the orders and instructions of the staff.

#### **4.5.4.3 WASTE ASSIGNMENT**

The spotters have to inform the deliverer about the location for waste unloading at the landfill. The following unloading areas should be available:

- waste disposal area;
- temporary storage areas for building materials, demolition waste, and earth excavation (cover material); and

Domestic hazardous waste requires a higher degree of containment. Ideally this waste fraction should be sent to the nearest TSDF. In case this is not possible the SLF should have a special storage area for domestic hazardous waste, to be transported to the nearest TSDF periodically. In the absence of a TSDF in the vicinity, to which this waste may be economically transported, it is preferable to construct a double liner cell for the domestic hazardous waste within the landfill site. The weighbridge operator will provide information regarding the temporary roads to be used. This has to be supported by corresponding traffic signs and by additional staff (spotters), who duly direct the vehicles. Driving on the loose landfilling area is not allowed.

#### 4.5.4.3.1 Preparing of Filling Plans

A final structural plan of the waste body of the landfill site should be designed. Based on this plan, different filling sections can be developed to ensure that

- staff could efficiently undertake all operational duties required in the landfill site, and
- the filling follows the designed waste body to avoid secondary transfer of waste.

#### 4.5.4.4 FILLING AND COMPACTION PROCEDURE OF WASTE

A high degree of waste compaction extends the lifetime of the landfill, reduces the need for cover material, reduces litter problems, and minimises long-term land requirements. Figure 4.20 illustrates the filling and compaction method to be employed, both along active flat fill areas and along slopes.

- The daily filling area should be determined every morning. It should be wide enough to prevent a backlog of vehicles. For safety reasons, the width of the landfilling face should not be reduced to less than 15 m.
- Incoming waste is unloaded in a pre-designated area (operation layer 1). This waste is then pre-compacted and moved to the active fill area (operation layer 2).
- Along slopes, to maximise compaction and to provide an optimal weight distribution of the bulldozer, the waste should be spread up a 1:3 slope in 50 cm layers.



- Good compaction is achieved by operating the landfill compactor up and down the filling area three to five times on the waste layers.
- The top view indicates the placement of freshly unloaded waste in operation layer 1 and its final placement and compaction along the slopes and in the operation layer 2.

Figure 4.20: Filling and Compaction Method<sup>27</sup>

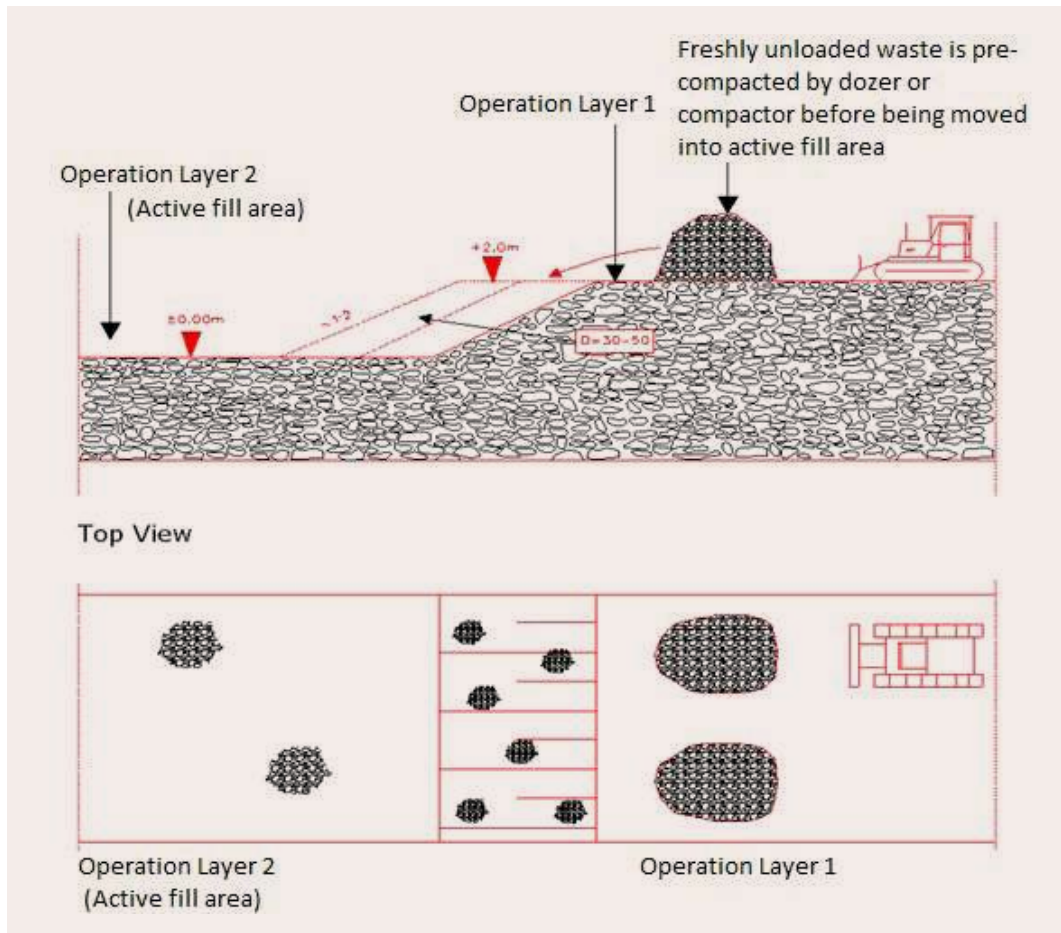

Figure 4.21: Landfill Compactor<sup>28</sup>



27 Internal GIZ document for preparation of MSWM manual, GIZ-IGEP (2014).

28 Ibid.

#### 4.5.4.5 COVERING OF WASTE

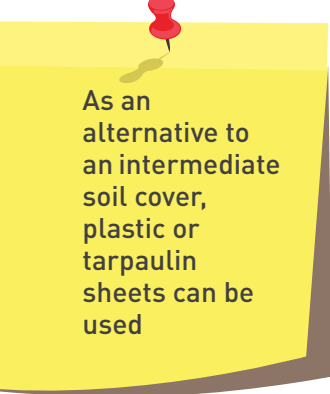

As an alternative to an intermediate soil cover, plastic or tarpaulin sheets can be used

Cover material includes imported cover such as (i) soil and other inert waste; and (ii) other material such as fine portion of C&D waste, street sweepings, and dry drain cleaning silt. The cover soil should be pushed by a bulldozer or wheel loader up the slope and spread out as evenly as possible. When constructing a body in an open area, the side slopes also require soil cover.

##### 4.5.4.5.1 Daily Cover

Waste placed at the landfill should be covered at the end of operations each day. The daily cover should be at least 10 cm thick and may comprise of soil, crushed C&D waste, and other inert waste.

##### 4.5.4.5.2 Intermediate Cover

In addition, the top and side surfaces of a completed structure of waste that is not intended to be covered within 180 days by another waste layer may be exposed to weather and truck traffic. These surfaces should be covered with a layer of at least 30 cm of compacted soil, street sweepings, dry drain silt, or compacted fine C&D waste. Surface water drainage should be built to minimise the volume of water entering the site.

The intermediate cover material should be removed as much as possible prior to applying waste over it. Soil removal or scarifying intermediate cover soil is essential to ensure controlled liquid conductivity between sections.

##### 4.5.4.5.3 Temporary Surface Cover

When the waste body has reached the final planned grade, a temporary cover of compacted soil or compacted fine C&D waste should be placed. This cover is necessary to allow light traffic movement without exposing any waste. The temporary cover will also help keep the rain from seeping into the waste.

##### 4.5.4.5.4 Covering during the Monsoon

Depending on the climatic conditions, the unused filling areas should be covered during the monsoon period. The recommended intermediate cover is 45 cm of soil or alternatively a waterproof cover material. The soil shall be tilled, compacted in at least two lifts, graded to promote runoff and limit infiltration, and either mulched or seeded to prevent erosion.

Prior to the area being used for disposal again, the intermediate cover shall be removed before any further landfilling can occur.

#### **4.5.4.6 FINAL COVER (SURFACE SEALING SYSTEM)**

To minimise infiltration of storm water in the landfill body and to allow storm water runoff, a surface sealing system has to be installed after the final completion of each landfill part. The main purposes of the final cover system are to:

- control the amount of storm water filtration into the waste to reduce leachate quantities;
- prevent erosion;
- To minimise the migration of greenhouse gases (GHG) into the atmosphere;
- protect the base sealing (impermeable) layer; and
- to minimise other emissions causing negative impacts on the environment.

#### **4.5.4.7 LANDFILL GAS MANAGEMENT**

A large part of mixed waste (50%–60%) consists of biodegradable parts which produce methane gas. With a view to reduce GHG emissions and thereby reduce environmental impacts, it is mandatory to install a degassing system for the sanitary landfill.

The gas management strategies should follow one of the following options:

- controlled passive venting; or
- controlled active collection and treatment or reuse.

##### **4.5.4.7.1 Controlled Passive Venting**

For all sanitary landfills, controlled passive degassing systems in the form of gas windows covered by suitable passive gas vents is recommended. Figure 4.22 illustrates placement of passive vents in a landfill.

The gas windows are to be installed in the frame of the final covering. The gas windows are openings in the cover system which may be filled with compost to avoid the generation of bad odours. The size should be not less than 1 m x 1 m, and the distance between two gas windows should be about 20 m.

**Figure 4.22: Placement of Passive Vent<sup>29</sup>**

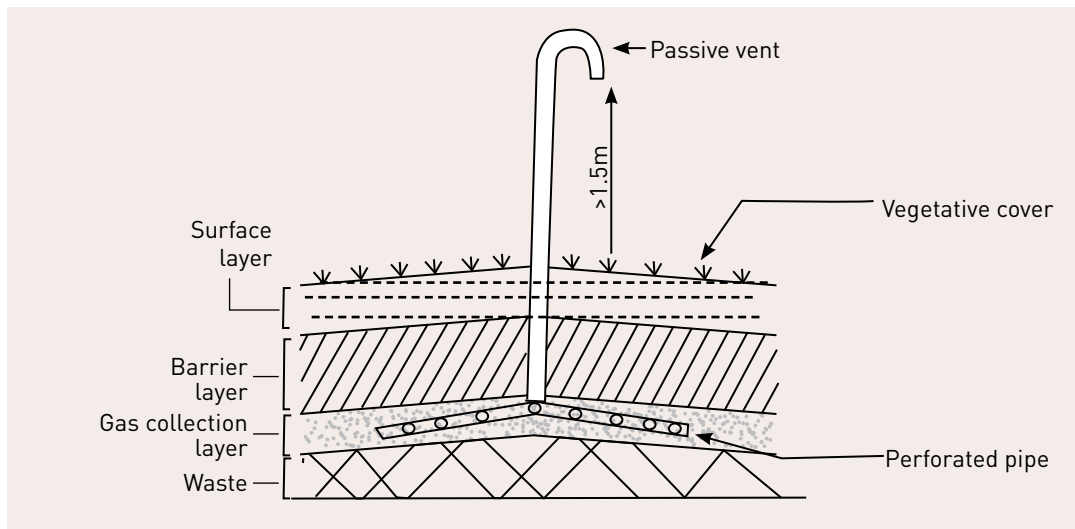

#### **4.5.4.7.2 Controlled active collection and treatment or reuse**

In order to reduce GHG emissions, especially methane with its very high global warming potential, future landfills should always install active gas collection systems. The active degassing system should contain the following elements as illustrated in Figure 4.23:

- **Gas collection wells:** Each well should cover a collection area of around 2,000 m<sup>2</sup>.
- **Gas transporting pipes:** From each gas well, HDPE gas transporting pipes will be installed on the waste during the filling procedure and connected via the main collection pipe to the compressor station and the flare.
- **Compressor station and gas use or flare system:** The gas can be fed into a blower station and a flare, which burns the methane to carbon dioxide (CO<sub>2</sub>) and water. This slightly reduces the warming potential, as CO<sub>2</sub> has lower warming potential than methane. Much better in terms of climate change mitigation and resource efficiency is the use of the gas to produce electric power through a generator.
- **Gas generator:** The installation of a gas generator can be profitable if after a landfill lifetime of 3–5 years, sufficient gas will be available.

<sup>29</sup> Manual on Municipal Solid Waste Management (First Edition), Central Public Health and Environmental Engineering Organisation (CPHEEO), 2000.

**Figure 4.23: Gas Recovery through Wells-Active<sup>30</sup>**

Controlled collection and treatment or use should be adopted only based on a feasibility study by experts in this area.

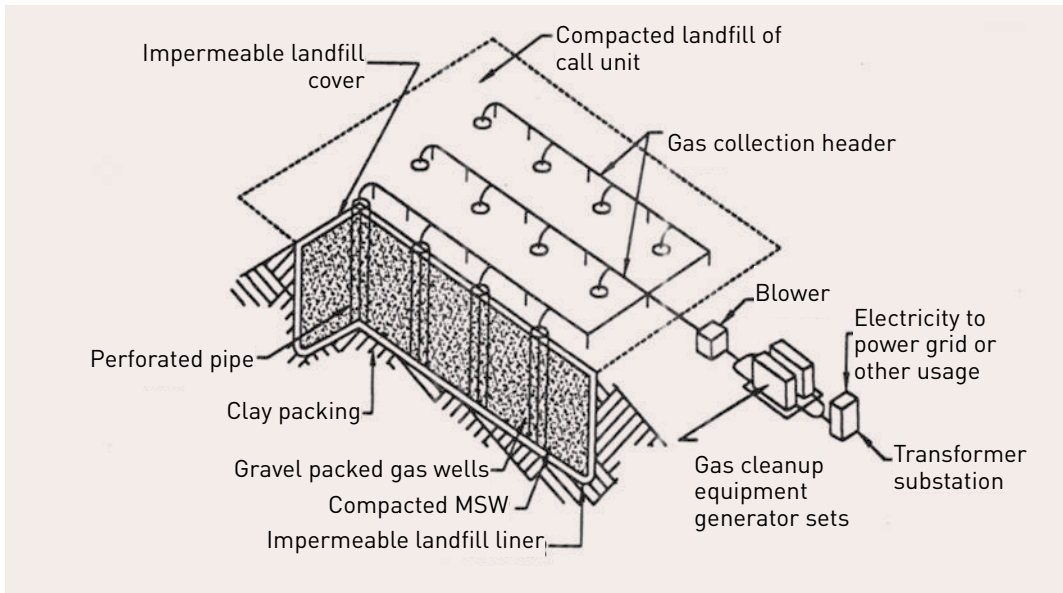

#### **4.5.4.8 SANITARY LANDFILL ROADS**

##### **4.5.4.8.1 Road Construction**

An important part of the landfill operation activities is enabling vehicles to reach the landfilling area, which is progressing every day, and to cover the waste once it is landfilled. Therefore, continuous road construction is required.

##### **4.5.4.8.2 Main and Temporary Roads**

Access to the different filling sections and the top layers of the landfill site is possible by constructing main access roads. These roads, with a maximum slope of 10%, should have a hard surface and be protected with a lateral ditch to drain the surface water flowing from the temporary capping surface. These main access roads should be wide enough (7–8 m) for two-way vehicle traffic. Chained equipment should not be allowed to travel on the main access road, as this is likely to cause damage.

The temporary side roads lead from the main access roads to the disposal face and therefore have a short life. Placement of these roads has to be conducted based on the instructions of the operation manager. These roads are typically made of waste demolition material which has been delivered for disposal at the site. On the top, 20–30 cm of gravel or other similar waste type can be used.

30 Ibid.

### 4.5.4.8.3 Road Maintenance

The following road maintenance should be undertaken:

- (i) **Filling of potholes:** Potholes should be filled with materials compatible with the roadbed.
- (ii) **Filling of areas where settlement occurs:** When roads are built on filling areas, settlement of the waste body may cause cracks on a road or cause the slope of a road to change. Cracks should be filled with material that is compatible with the roadbed.
- (iii) **Maintenance of roadside ditches:** All ditches should be kept free of obstructions and debris. Inspections of all drainage ditches and structures should be made at least once a week, after the rain, or more frequently as required. Any debris should be removed from ditches.

### 4.5.4.9 STORM WATER MANAGEMENT

All surface water ditches, culverts, drainage channels, and settling ponds (storm water ponds) should be designed by a hydrologist using hydrometeorological data.

#### 4.5.4.9.1 Surface Water Collection

Surface water management is required to ensure that rainwater runoff does not drain into the waste from surrounding areas and that there is no water logging or ponding on covers of landfills.

These objectives should be achieved by the following:

- Rainwater running off slopes above and outside the landfill area should be intercepted and channeled to water courses without entering the operational area of the site. This diversion channel may require a low permeability lining to prevent leakage into the landfill.
- Rainfall on areas within the landfill site but on final covers of completed landfill segments should be diverted in drainage channels from active tipping areas, and directed through a settling pond to remove suspended silt, prior to discharge.
- Any drainage channels or drains constructed on any restored landfill surface should be able to accommodate settlement of the waste body, resist erosion, and cope with localised storm conditions.
- The final cover should be provided a slope of 2.5%–5.0% for proper surface water drainage. The final top cover slopes depend on the area of the top portion of the landfill; the larger the extent, the flatter the slopes. Figure 4.24 illustrates surface water drainage system in a landfill.

**Figure 4.24: Surface Water Drainage System in Completed Landfill<sup>31</sup>**

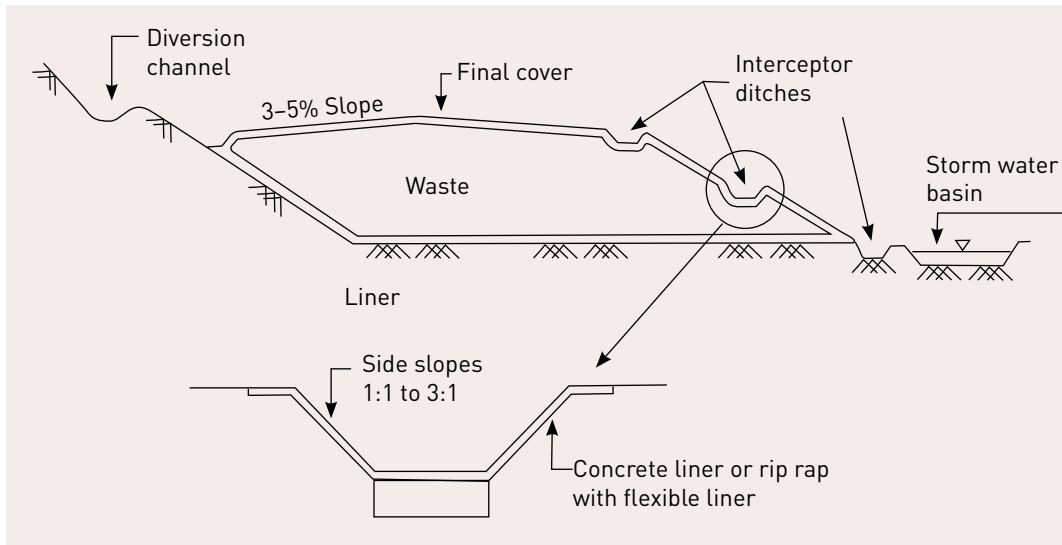

#### **4.5.4.9.2 Storm Water Retention Pond**

The storm water retention pond should be designed according to the local conditions. It should protect the downstream situated villages against flooding. The construction should be designed as a ground basin with a regular discharge to the receiving water course. However, the retained water can be used for irrigation purposes during dry climate conditions.

#### **4.5.4.9.3 Maintenance of the Storm Water System**

The landfill staff have to inspect the drains on a weekly basis. After heavy rainfall, the storm water system has to be inspected also and relieved from mud and sand. Regular cleansing is mandatory after heavy storm occurrences, as the pipes and ditches are most likely filled with papers and plastic bags. The storm water pond also has to be cleared of papers and plastics.

31 Manual on Municipal Solid Waste Management (First Edition), Central Public Health and Environmental Engineering Organisation (CPHEEO), 2000.

## 4.5.4.10 LANDFILL EQUIPMENT

### 4.5.4.10.1 Required Equipment

For controlled landfill operations, the equipment listed in Table 4.8 are required.

**Table 4.7: Equipment Required on a Sanitary Landfill<sup>32</sup>**

| EQUIPMENT  | FUNCTIONS  |
|--|--|
| Landfill Compactor   | Spreading and compaction of waste  |
| Dozer  | Spreading of waste and daily cover   |
| Backhoes and front end loaders                                     | Excavation and maintenance of ditches<br>Loading of waste and cover material             |
| Tractor trailers; water tank                                       | Internal movement of waste or daily cover<br>Soil transportation<br>Water transportation |
| Truck with tipper  | Soil transportation  |
| Light commercial vehicle or passenger vehicle                      | Staff transportation   |
| Poclains   | Heavy-duty excavation and embankment construction  |
| Soil compactors (sheepsfoot rollers and smooth steel drum rollers) | Finishing passes   |

The number of equipment required depend on the amount of landfilled waste and size of the landfill, and should be designed specifically for each sanitary landfill. An indicative list of equipment required based on the size of the landfill is given in Table 4.9.

**Table 4.8: Equipment required based on size of Sanitary Landfill<sup>33</sup>**

| EQUIPMENT                        | DAILY WASTE RECEIVED |              |                |
|----------------------------------|----------------------|--------------|----------------|
|                                  | 200 Tons             | 201–500 Tons | 501–1,000 Tons |
| Bulldozers <sup>a</sup>          | 2                    | 2            | 2              |
| Loaders                          | 2                    | 3            | 4              |
| Excavators                       | 2                    | 3            | 3              |
| Landfill compactors <sup>b</sup> | NA                   | 3            | 5              |
| Water tankers                    | 1                    | 1            | 2              |
| Tractor trailers or tippers      | 2                    | 4            | 6              |

Note: a More than 10 tonnes operating mass.

b More than 20 tonnes operating mass.

<sup>32</sup> Developed by the Expert Committee for revision of MSWM manual (2013-15)

<sup>33</sup> Ibid.



#### 4.5.4.10.2 Maintenance of Mobile Equipment

Regular mobile equipment inspections and operating records are critical for an effective preventive maintenance. To ensure maximum operating efficiency, inspections need to be thorough and accurately recorded by all operating personnel.

#### 4.5.4.11 HOUSEKEEPING ON THE SANITARY LANDFILL

Housekeeping should be conducted in such a manner that it protects the public and surrounding environment from risks and nuisance emanating from landfill operations. A well-controlled landfill operation will enhance public perception and acceptance of the landfill site.

The following general measures should be considered:

- **Vector and vermin control:** The landfill site might attract vectors and vermin because of the presence of organic waste. To avoid or reduce vectors and vermin, the filling area should be minimised and the waste covered at regular intervals.
- **Litter control:** Offsite litter should be picked up on a regular basis.
- **Noise control:** Noise in the landfill site arises from landfill operations and waste vehicles entering and leaving the site. During landfill operations, equipment with faulty or worn-out exhaust systems can cause high noise levels. Hence, they need to be repaired.
- **Dust control:** The combination of vehicle movements and winds on temporary and un-surfaced roads can create dust. Dust within and around a landfill site can be a source of annoyance, harm, and physical discomfort to landfill staff and neighbourhood. Therefore, all precautions have to be taken to avoid dust generation.
- **Odour control:** The landfill should be operated in a manner that will minimise the odour from waste or associated items. Operational procedures include placing suitable cover material over the waste in a timely manner.

##### 4.5.4.11.1 Health and Safety

The landfill management (municipality or private operator) should be responsible for all aspects of site safety, including public safety in areas adjoining the site. The safety officer of the municipality or of the private operator should also be responsible for the health and safety of landfill staff. He or she should support the landfill management in the following tasks:

- planning, operation, maintenance, and inspection of installations with regard to health and safety;

- organisation and realisation of training and instructions of landfill staff with regard to occupational health and safety;
- assessment and evaluation of accidents; and
- internal reporting on safety aspects.

#### **4.5.4.11.2 General Safety Measures**

General safety measures have to be applied during landfill operations, regardless of the nature of ongoing activity or location. Below is a list of priority measures, which should be elaborated, based on site-specific conditions:

- Maximum traffic speed should be 20 kilometers per hour (km/h).
- Every person working at the landfill should have a yearly medical examination.
- No one should be allowed to operate at the landfill without a mobile communication system (either radio or mobile telephone).
- Smoking should be prohibited except in designated smoking areas.
- Ingestion of food is restricted outside designated areas.
- General hygienic requirements have to be applied while working at the landfill.

#### **4.5.4.11.3 Person Related Safety Measures**

The workers have to be equipped with the following personal protection equipment:

- safety boots (always to be used while working outside the buildings);
- reflective vests (always to be used while working outside the buildings);
- safety helmets (to be used in case of risk of head injuries, e.g., during construction, loading or unloading activities, while operating machinery, etc.);
- gloves (to be used in case of risk of hand injuries, e.g., during loading or unloading, or maintenance activities);
- ear protectors (to be used while working in noisy areas); and
- disposable dust mask (to be used in case of exposure to dust).

The landfill management has to strictly enforce the use of personal protection equipment.

#### **4.5.4.11.4 First Aid**

The landfill workers should be trained in first aid, so that they themselves can properly provide first aid. Considering the specific conditions at a

sanitary landfill, it is strongly recommended that landfill staff working on a regular basis be trained on first aid. All vehicles working at or entering the landfill have to be equipped with a first-aid kit.

All vehicles working or entering the landfill have to be equipped with a first aid kit.

#### **4.5.4.11.5 Personnel Accidents**

In case of accidents involving injuries, the following procedures have to be applied:

- stop work immediately;
- inform first aider;
- inform management; and
- call medical services (ambulance emergency number should be duly filled in and maintained by the responsible landfill operator).

#### **4.5.4.11.6 Fire Prevention and Protection**

##### **General Requirements**

The following descriptions provide an overview of fire prevention and protection procedures. In any case, the actual firefighting operation is under the responsibility of the fire brigade of the urban local body (ULB).

To prevent fire incidents, the following rules have to be applied:

- Banning smoking in all areas of the sanitary landfill.
- Handling material on fire as well as setting fire to materials on the landfill are strictly forbidden.
- Waste that has been unloaded in the filling area has to be examined visually for potential fire sources (glowing ash or glowing burning remains). If fire sources are located, these have to be neutralised with cover material immediately.
- All mobile equipment or vehicles should be furnished with a fire extinguisher.
- Fire Control.

In case of fire, the following basic rules of conduct have to be complied with:

- Every fire has to be reported immediately.
- The preservation and protection of lives and health have priority over firefighting.
- Alarm signals should be heeded.

#### **4.5.4.12 ENVIRONMENTAL MONITORING**

The environmental monitoring of landfills should be performed as per SWM Rules, 2016 requirements (Section 4.1 of this chapter). In addition, hydrogeology and surface water quality at the landfill site should be monitored as discussed in Section 4.5.1.9 of this chapter.

#### **4.5.5 CLOSURE AND POST CLOSURE PLAN**

Determination of the end use of a landfill site is an essential part of the plan for landfill closure and post-closure maintenance. A closure and post-closure plan for landfills involves the following components:

- plan for vegetative stabilisation of the final landfill cover,
- plan for management of surface water runoff with an effective drainage system,
- plan for periodical inspection and maintenance of landfill cover (settlements) and facilities,
- plan for quantity and quality of leachate monitoring in the landfill,
- plan for quantity and quality of landfill gas monitoring,
- plan for groundwater quality (up gradient and down gradient), and
- plan for surface water quality at the periphery of landfill and at receiving water bodies.

The regulatory limits for various parameters of quality and the monitoring frequency will have to be agreed or stipulated by the regulatory authorities.

The post-closure care of landfill site shall be conducted for at least 15 years in line with the SWM Rules, 2016 as mentioned above. The authority or concessionaire that operated the sanitary landfill shall be responsible for post-closure activities and monitoring.

#### **4.5.5.1 PLANTATION AT LANDFILL SITE**

As per the SWM Rules, 2016 Schedule I (g), there is a defined criteria for plantation at the landfill site which needs to be adhered to. Please refer to Section 4.1 of this chapter.

#### **4.5.6 CONSIDERATIONS FOR LANDFILL COSTING**

Landfill construction includes several cost elements. An indicative list of elements or components of a sanitary landfill is provided in Table 4.10.

**Table 4.9: Components of a Sanitary Landfill<sup>34</sup>**

|     |  |  |
|-----|--|--|
| 1.  | <b>Earthworks</b>                        |  |
|     | 1.1                                      | Site clearing or cleaning  |
|     | 1.2                                      | Excavation and fill (as per plan)                                  |
| 2.  | <b>Landfill liner</b>                    |  |
|     | 2.1                                      | Clay liner and bentonite mix (if applicable)                       |
|     | 2.2                                      | Leachate collection system (LCS)                                   |
|     | 2.3                                      | Granular or sand drainage placement                                |
|     | 2.4                                      | High-density polyethylene (HDPE) liner material                    |
|     | 2.5                                      | Geotextile filter fabric   |
| 3.  | <b>Leachate collection system</b>        |  |
|     | 3.1                                      | LCS gravel placement   |
|     | 3.2                                      | HDPE raiser pipe   |
|     | 3.3                                      | HDPE header pipe   |
|     | 3.3                                      | HDPE lateral pipe  |
|     | 3.4                                      | Leachate transfer pump   |
|     | 3.5                                      | Leachate holding tank (sump)                                       |
|     | 3.6                                      | Piping from holding tank to lagoons or treatment plant             |
| 3.7 | Leachate treatment plant                 |  |
| 4.  | <b>Top cover</b>                         |  |
|     | 4.1                                      | Impermeable clay layer (mixed with bentonite if needed)            |
|     | 4.2                                      | Gas venting system (passive venting, flaring, or treatment system) |
|     | 4.3                                      | Top cover drainage gravel placement                                |
|     | 4.4                                      | Top soil placement   |
| 5.  | <b>Storm water control</b>               |  |
|     | 5.1                                      | Peripheral storm water drains or collection system                 |
|     | 5.2                                      | Storm water detention pond   |
|     | 5.3                                      | Pumps  |
|     | 5.4                                      | Berm construction  |
| 6.  | <b>Buildings or structures</b>           |  |
|     | 6.1                                      | Administration building  |
|     | 6.2                                      | Temporary hazardous waste storage                                  |
|     | 6.3                                      | Repair and maintenance, parking                                    |
|     | 6.4                                      | Stockpile room   |
|     | 6.5                                      | Truck tyre washing facility  |
|     | 6.6                                      | Culverts   |
|     | 6.7                                      | Administration building parking                                    |
|     | 6.8                                      | Boundary fencing   |
|     | 6.9                                      | Landscaping  |
|     | 6.10                                     | Roads  |
| 7.  | <b>Fire control</b>                      |  |
|     | 7.1                                      | Fire control equipment   |
| 8.  | <b>Contracted or purchased equipment</b> |  |
|     | 8.1                                      | Excavator  |
|     | 8.2                                      | Site waste haulage truck   |
|     | 8.3                                      | Water tanker   |
|     | 8.4                                      | Landfill compactor   |
|     | 8.5                                      | Weighbridge  |
|     | 8.6                                      | Bull dozers  |
|     | 8.7                                      | Personal protective equipment                                      |

<sup>34</sup> Developed by the Expert Committee for revision of MSWM manual (2013-15)

## 4.5.7 EXISTING DUMPSITE CLOSURE OR RECLAMATION

Many open solid waste dumpsites in India do not have an engineered liner system, leachate collection system (LCS), or an appropriately designed cover system, thus posing a threat to the environment and human health. Such dumpsites should be immediately closed to minimise their impact on land, groundwater, and surface water quality and on air quality in the vicinity of the dumpsite. Repeated burning of wastes on dumpsites cause deleterious environmental impacts.

### 4.5.7.1 DUMPSITE CLOSURE

Closure of municipal solid waste (MSW) dumpsite assumes great importance because each city has more than one dumpsite, which create significant health and environmental degradation. This activity requires huge logistics depending on the size of the heap, climatic condition of the place, and the plan for its future use. The requirement of logistics and time frame increases multifold in case site reclamation is planned. Some options are mentioned below, although more options can be worked out depending on the site conditions and prospects of utilisation of the retrieved material in case of reclamation.



As per Schedule I of SWM Rules, 2016:

J. Closure and Rehabilitation of Old Dumps- Solid waste dumps which have reached their full capacity or those which will not receive additional waste after setting up of new and properly designed landfills should be closed and rehabilitated by examining the following options:

- (i) Reduction of waste by bio mining and waste processing followed by placement of residues in new landfills or capping as in (ii) below.
- (ii) Capping with solid waste cover or solid waste cover enhanced with geomembrane to enable collection and flaring / utilisation of greenhouse gases.
- (iii) Capping as in (ii) above with additional measures (in alluvial and other coarse grained soils) such as cut-off walls and extraction wells for pumping and treating contaminated ground water.
- (iv) Any other method suitable for reducing environmental impact to acceptable level.

Dumpsite closure may be carried out through any of the following means, as may be feasible at the site:

- The waste has to be placed in a new landfill with liner and cover in accordance with SWM Rules, 2016 (Figure 4.25). Attempts are being made towards adopting appropriate process for dumpsite closure, however, this area need definite guidelines.

**Figure 4.25: Old Waste in New Landfill<sup>35</sup>**

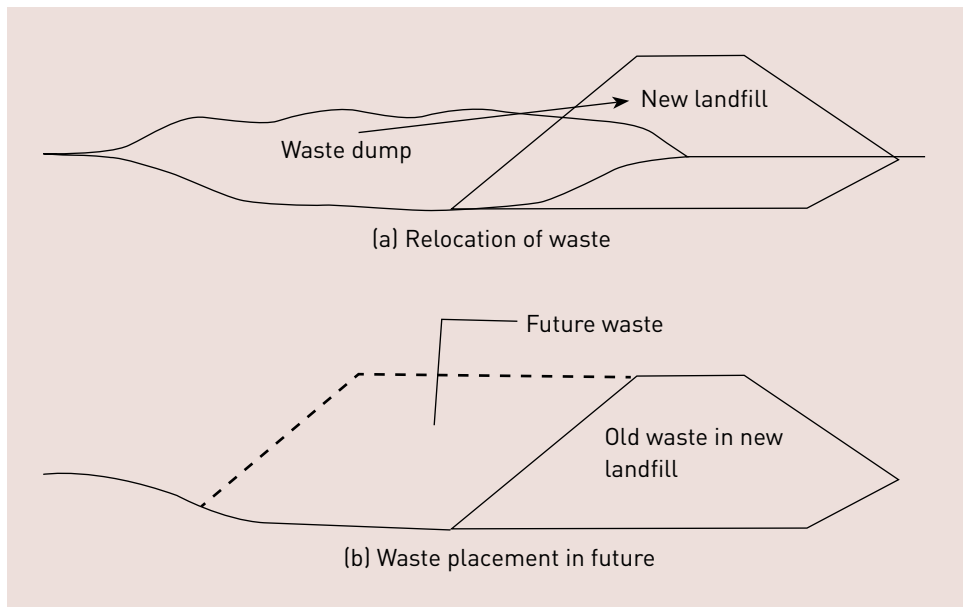

- Closure should be by re-grading to a stable slope of minimum 1:3, and top cover system should be provided to reduce percolation of rainwater (Figure 4.26). In areas close to water bodies, creek, and coastal zones, a vertical cutoff wall should be planned at an appropriate depth.

**Figure 4.26: Closure of Old Waste Dump with Cover<sup>36</sup>**

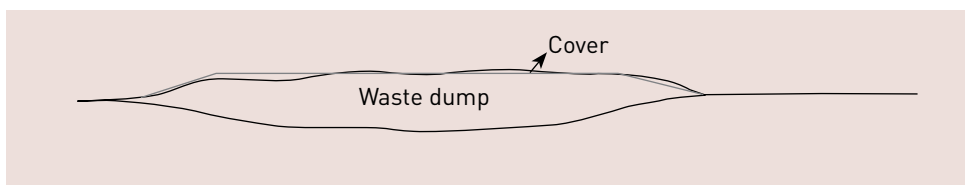

- Closure by other means should be with approval from the concerned State Pollution Control Board (SPCB) and committee.
- Leachate generation from old and existing dumpsites is the biggest environmental hazard. However, it is not possible to lay a bottom liner below an existing dumpsite. One effective way is to stop ingress of rainwater from the top.
- Provide top cover to prevent rainwater infiltration. Over time, leachate generation from such covered dumps will be reduced. Ensure the presence of a HDPE liner in the top cover of the landfill, above the drainage layer.
- Gas wells have to be sunk into the waste dump, equivalent to the average height of the landfill from ground level.
- There should be grading of the existing dumpsite to ensure slope stability.

<sup>35</sup> Guidelines and Check-list for evaluation of MSW Landfills proposals with Information on existing landfills, CPCB, 2008. Available at: [http://cpcb.nic.in/upload/NewItems/NewItem\\_133\\_MS-W-REPORT.pdf](http://cpcb.nic.in/upload/NewItems/NewItem_133_MS-W-REPORT.pdf)

<sup>36</sup> Ibid.

- Dumpsite closure should ideally be planned after incoming waste is no longer accepted. In case fresh waste is allowed at the dumpsite, the waste should be placed only in select zones.
- Like for other sanitary landfill, post-closure care should be 15 years with monitoring of leachate (to be treated or sent to a sewage treatment plant [STP]), gas generation, and groundwater quality (in monitoring wells).
- There should be inspection for subsidence, cracks, and fissures in the top cover to ensure their prompt repair.
- If vegetation is planned in the top cover, adequate provision for irrigating the plants should be made.

#### **4.5.7.2 DUMPSITE RECLAMATION**

Dumpsite reclamation or mining creates additional space for future landfilling needs and avoids or reduces the cost of acquiring land for dumping of municipal waste. Further potential for groundwater contamination is reduced through remediation of unlined open dumpsites. In addition, it also reduces the cover requirements for existing dumps by reducing the footprint of the landfill.

Dumpsite reclamation involves excavation, screening, and separation of material from dumpsites into various components such as soil, recyclable materials, and residues.

#### **4.5.7.3 METHOD FOR DUMPSITE RECLAMATION**

Dumpsite reclamation involves sorting out mixed municipal waste according to material size (oversized material, intermediate sized waste and soil or humus) by using a trommel. The size and type of screens used depend on the end use of the recovered material. Dumpsite reclamation typically consists of two basic operations: excavating waste and screening waste.

##### **4.5.7.3.1 Excavation**

The old waste dump contains leachate at different layers and various gases and odor-causing substances. Before starting excavation, it is necessary to vent out the gases and drain out the leachate. Ventilation systems for application to such situations have been developed. Basically, it comprises blowing or sucking air from designated areas for 2 days before breaking open the dump for excavation. The exhaust air is passed through filters (preferably bio-filter) to trap the harmful gases. Excavation of waste material from the dump is then initiated. A frontend loader then organises the excavated materials into manageable stockpiles and separates oversized or bulky material.



### 4.5.7.3.2 Screening

Waste screening begins with the segregation of excavated material into discrete streams. An electromagnet is used to segregate ferrous material from the main stream of waste. The nonferrous fraction is processed through an air classifier that separates light materials from heavy organics. A trommel or vibrating screen separates soil from solid waste. Trommel screens are more effective than vibrating screens.

The sizes and types of screens used depend on the end use of the recovered material. For example, if the reclaimed soil is used as landfill cover, a 50 mm screen is used for separation. If, however, the reclaimed soil is sold as construction fill or for another end use requiring fill material with a high fraction of soil content, a smaller mesh screen is used to remove small pieces of metal, plastic, glass, and paper. Operation costs can be retrieved by the sale or reuse of the recovered materials such as recyclables, soil, and waste. The recovered land may also be monetized to recover costs of remediation.

Further use of recovered land is to be carefully considered after assessing the nature and impact of any site contamination (soil or hydrological) due to the reclaimed dumpsite. In many cases, such sites may be found suitable only for the construction of engineered sanitary landfills for MSW or hazardous solid waste.

Material recovery depends on the composition of waste, effectiveness of mining technology, and efficiency of mining technology. The material recovery ranges from 50% to 90%, while average soil fraction in recovered municipal waste from landfill tends to be around 50%–60%. However, it can vary between 20% and 80% depending on moisture content and decomposition rate. The success of dumpsite reclamation projects depends on the age of the dumpsite and composition of the decomposed waste.<sup>37</sup>

It is to be noted that dumpsites which are subject to repeated burning, spontaneous or not, will have minimal potential for reclamation and recovery of material. Unless the recovered organic material is proved to be free from contamination (items indicated in Fertilizer Control Order [FCO], 2009 and 2013), it should not be used as manure for food crops.

#### Advantages of Dumpsite Reclamation

- Dumpsite reclamation results in recovery of land for further use, e.g., constructing engineered landfills.
- Revenue is generated from the sale of recyclable material such as ferrous metals, plastics, and soil.

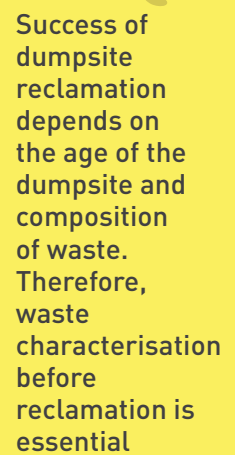

Success of dumpsite reclamation depends on the age of the dumpsite and composition of waste. Therefore, waste characterisation before reclamation is essential

- Reclaimed soil can also be used as daily cover material in landfill cells, thus avoiding the cost of importing cover soil.
- Combustible waste from the landfill can be used for the production of refuse derived fuel (RDF) and sold to cement or power plants for co-processing or co-incineration.
- Dumpsite reclamation avoids or reduces costs of dumpsite closure and post-closure care and monitoring.

### Disadvantages of dumpsite reclamation

However, dumpsite or landfill reclamation can result in excessive costs, which are not justified by the sale of soil or recyclables, unless the recovered land is of a significant economic value. Inherent hazards of pockets of landfill gas and exposure to hazardous and explosive material are also to be considered, depending on the level of control on waste disposal at the facility and location of the dumpsite or landfill.

Dumpsite or landfill reclamation can result in excessive costs, which are not justified by the sale of soil or recyclables, unless the recovered land is of a significant economic value



#### An Example of Scientific Landfill Closure and Methane Capture: Gorai Dumping Ground, Mumbai

**Background:** Closure and scientific capping of garbage dumpsite is essential for containing its pollution potential. Usually, old dumpsites are left without any remedial steps and allowed to degenerate over the years in terms of leachate percolating down to groundwater, vector breeding, and air pollution. Some dumpsites have been covered with thin layer of soil and vegetation to beautify the area. However, generation of leachate continues. With ingress of rainwater, more leachate is formed. This goes on for years until the material in the landfill is stabilized, which may be 20–50 years in warm climates.

The first known example of scientific capping of a garbage dumpsite in India happened in Mumbai at Gorai dumpsite. This is a specific example where an ongoing dumpsite was systematically closed and then capped. Normally, this procedure would be well suited for already closed dumpsite where dumping of fresh garbage has been stopped.

Operational since 1972, Gorai dumpsite is in the western suburbs of Mumbai. The 19.6-hectare site is adjacent to Gorai creek and is very close to habitation. Approximately 2.34 million tons of waste up to an average height of 26 m was lying at the site, causing significant environmental damage to the creek and the neighborhood. The capacity of the dump was already exhausted. The creek waters had been polluted due to inflow of leachate, and the air quality had deteriorated from the frequent burning of garbage.

The Municipal Corporation of Greater Mumbai (MCGM) took up this challenge and, with technical assistance of Infrastructure Leasing & Financial Services Ltd (IL&FS) (Environment Division), worked out a scientific plan for controlled closure and scientific capping based on detailed survey and consultation.



**Gorai dumpsite:** before closure

### Design Strategy and Action Plan

Since it was not possible to go under the huge dump to lay a containment layer, gradual reduction of leachate was planned by restraining rainwater from entering the dump by providing a multilayered cover over the dump. At the same time, a leachate collection system (LCS) was planned in the best possible manner. Ingress and inundation of tidal water was controlled by putting vertical concrete sheet piling on the creek side.

The scientific closure plan included the following components:

- (i) fresh dumping stopped and relocation and slope reformation (1:3) of existing waste;
- (ii) laying of construction and demolition (C&D) waste and compaction;
- (iii) laying of liner system consisting of:
  - (a) top vegetation layer;
  - (b) 300 mm thick top soil layer;
  - (c) geocomposite layer;
  - (d) 1.5 mm geomembrane layer;
  - (e) 200 g/m<sup>2</sup> and 400 g/m<sup>2</sup> geotextile; and
  - (f) 300 mm thick drainage layer;
- (iv) installation of landfill gas collection, venting, and flaring system;
- (v) installation of LCS using perforated pipes along the periphery of the fill, followed by storage in a leachate tank and transportation to the nearest sewage treatment plant (STP);
- (vi) sheet piling on the seaward side to prevent leachate from entering the creek;
- (vii) surface water drainage for channeling storm water;

- (viii) construction of bunds, access roads, and compound wall on the landward side of site;
- (ix) landscaping and greenery, irrigation, and lighting of the area; and
- (x) post-closure care for 15 years with close monitoring of the indicative parameters like leachate, watering and maintaining the greenery, checking leakage of landfill gas, checking subsidence of the cover layer, etc.

The construction and operation and maintenance (O&M) contract for this work was awarded through open competitive bidding to a consortium of an Indian and a German company. The construction was completed in 24 months with a cost of about Rs.50 crore, with the O&M estimated at Rs.12 crore for 15 years of post-closure care.



**Gorai Dumpsite:** After Scientific Closure

### **Outcome**

**The following are the outcomes of the project:**

1. There has been a marked improvement in quality of life of people living in the vicinity.
2. The project has created 19 hectares of green space and restored mangroves which had degenerated due to toxic leachate from the dumpsite.
3. The project has improved public health and hygiene; eliminated foul odor, fire, and vermin nuisance; improved the quality of creek water; and increased avian fauna population.
4. Property value in the area increased with higher property tax collection for the MCGM.

An important aspect of this project is the demonstration impact, which can be modified for local requirements and replicated across old open dumpsites in the country.

*Source: MCGM and IL&FS.*

#### 4.5.7.4 EXPANSION OF LANDFILL OPERATIONS IN EXISTING WASTE DUMP OR LANDFILL

Expansion of landfilling operations at an existing site should only be undertaken after closure of the existing waste dump or existing landfill without liner. The expansion can take place in the form of (i) a new landfill adjacent to the existing dump which has been closed (Figure 4.27), or (ii) a new landfill constructed adjacent to the existing dump by making space for it by relocating existing waste from the sides of the waste dump to its top and then closing the waste dump (Figures 4.28, 4.29 a and b). In both such cases, the new landfill should conform to the check list as prescribed by CPCB in the guidelines and check-list for evaluation of MSW landfill proposals. For option (ii), the operator shall list the steps for odour control during relocation of the waste.

Vertical expansion of an existing waste dump or existing landfill should not be undertaken by placing a cover on the waste dump and filling on top of the cover. This is so because the cover between the old waste and the new waste would be subjected to large settlements and may not perform satisfactorily. Wherever it is stated that large settlements will not occur or that these can be withstood effectively, the proposed design should be checked by an expert.

**Figure 4.27: Expansion of Waste Dump<sup>38</sup>**

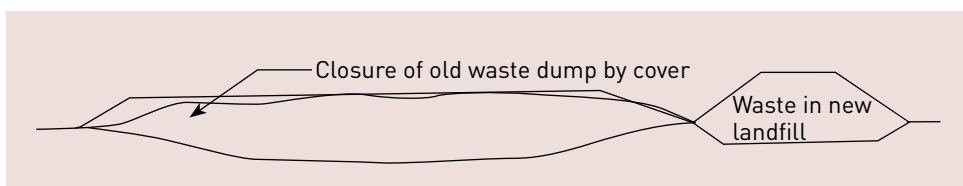

**Figure 4.28: Relocation of Waste<sup>39</sup>**

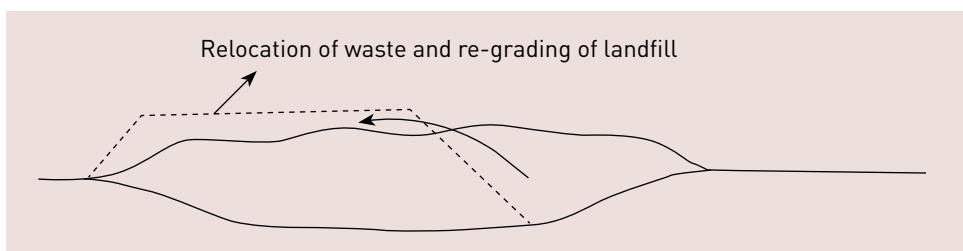

**Figure 4.29a : Horizontal Expansion (Option A – preferred)<sup>40</sup>**

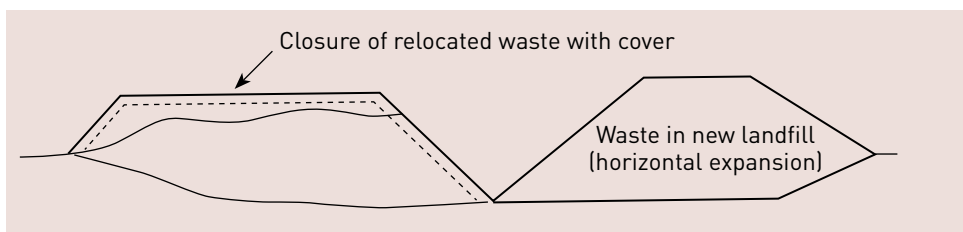

38 Guidelines and Check-list for evaluation of MSW Landfills proposals with Information on existing landfills, CPCB, 2008. Available at: [http://cpcb.nic.in/upload/NewItems/NewItem\\_133\\_MS-W-REPORT.pdf](http://cpcb.nic.in/upload/NewItems/NewItem_133_MS-W-REPORT.pdf)

39 Ibid.

40 Ibid.

**Figure 4.29b: Horizontal Expansion (Option B)<sup>41</sup>**

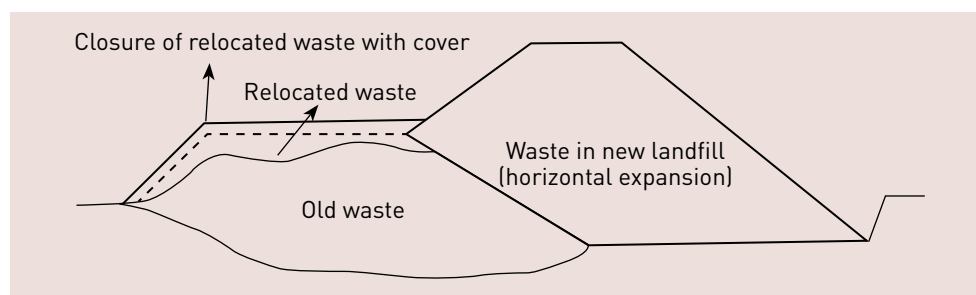

#### **4.5.7.5 ASSESSING UTILITY OF THE CLOSED OR COVERED DUMPSITE – POST 15 YEARS**

- Leachate generation from the closed dumpsite and the year in which leachate generation has stopped should be recorded.
- The closed or covered landfill should be assessed for its stability, and a record of the subsidence over the past 15 years should be evaluated.
- Groundwater quality in wells on-site and in the neighbourhood should also be monitored throughout the 15 years.
- Structural experts should evaluate the stability, strength, and load-bearing capacity of the area. Based on this evaluation, the ULB should decide on appropriate use of the closed dumpsite.
- The town planning department should take cognizance of all existing and potential reclaimed dumpsites and include the same in the master plan or land use plan of the ULB. Strict development controls of such areas should be adhered to.
- No borewell should be allowed within the footprint of the reclaimed dumpsite and within 500 metres of its boundary. Where groundwater extraction is inevitable within the 500 m zone, groundwater flow direction should be considered. Borewells should not be established downstream to the dumpsite, along the flow path.
- The closed landfill may be used for the following development, which should be taken up 3 years after complete cessation of leachate generation:
  - development of local markets;
  - development of urban parks; and
  - development of office, commercial, or institutional space (after ascertaining safety and assessing requirement of relevant controls).

<sup>41</sup> Ibid.

## **4.6 ACTION POINTS FOR AWARENESS GENERATION THROUGH INFORMATION, EDUCATION, AND COMMUNICATION ACTIVITIES FOR MUNICIPAL SANITARY LANDFILLS**

- Explain the role of landfill in the waste management scheme of the city to ensure citizens' support.
- Consult public for resettlement and compensation issues related to earmarking spaces for landfill.
- Ensure an understanding that only inert wastes shall be disposed in the landfill.
- Educate the public on the environmental and safety provisions of the landfill.
- Educate the community to ensure maintenance of no-development buffer zones around the landfill area.





**Municipal  
Solid Waste  
Management Plan  
Implementation**

## IN THIS SECTION

|     |  |     |
|-----|--|-----|
| 5.1 | Obtaining Statutory Clearances for Municipal Solid Waste Management  | 428 |
| 5.2 | Preparation of Action Plans and Detailed Project Reports   | 435 |
| 5.3 | Considerations for Contracting A Municipal Solid Waste Management Service  | 443 |
| 5.4 | Tendering, Contract Management and Supervision   | 448 |
| 5.5 | Operationalising the Financial Plan  | 462 |
| 5.6 | Action Points for Awareness Generation Through Information, Education, and Communication Activities for Municipal Solid Waste Management Plan Implementation | 463 |

## 5. MUNICIPAL SOLID WASTE MANAGEMENT PLAN IMPLEMENTATION

The chief executive of the urban local body (ULB), i.e., municipal commissioner or secretary or executive officer, is responsible for implementing the municipal solid waste management (MSWM) plan, which is to be developed in line with guidance given in Section 1.3 of Part II. The chief executive should operationalize the plan through the solid waste management (SWM) department or cell of the ULB.

The MSWM plan is meant as a long term plan for 20–25 years. The implementation of the MSWM plan is guided by short term MSWM plans for 5 years, which are made in line with the goals of the long term plan. These short term MSWM plans can be reviewed midterm once every 2–3 years. An indicative list of actions that can be undertaken to develop a short term MSWM plan is given in Table 5.1 below.

The chief executive of the ULB is responsible for the successful implementation of the MSWM plan

**Table 5.1: Actions for Preparation of Short term Municipal Solid Waste Management Plan<sup>1</sup>**

| ACTION   | IMPLEMENTING AGENCY                                    |
|--|--|
| Identification of specific actions for 5 years (short term plan) to ensure planned SWM service provision as per the long term plan   | ULB  |
| Preparation of detailed project reports for specific projects (e.g., transfer station, processing, treatment, and disposal facilities) and action plans for service provision (e.g., transportation) | ULB or private implementing agency, as the case may be |
| Identification of institutional mechanisms to support provision, monitoring, and reporting on specific SWM services  | ULB  |
| Implementation of programmes for SWM staff capacity building (service provision, monitoring, reporting)  | ULB  |

**Figure 5.1: Components of Municipal Solid Waste Management Plan<sup>2</sup>**

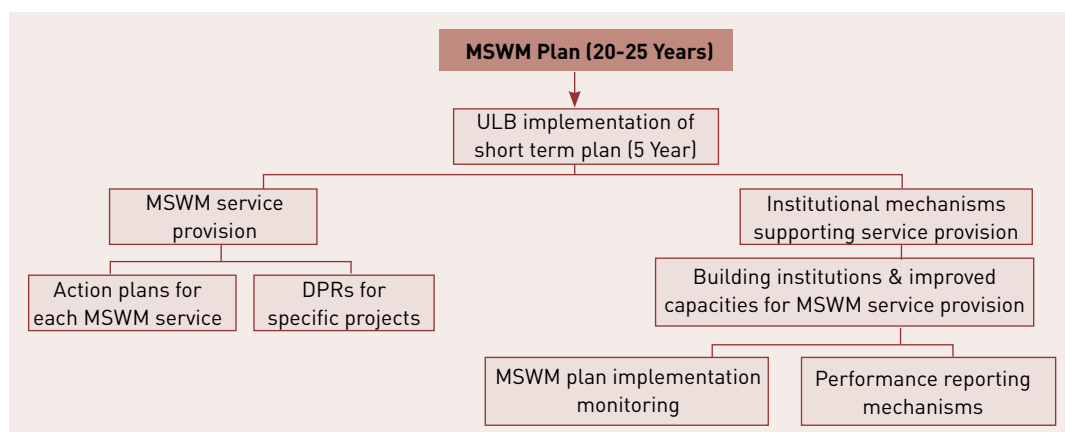

<sup>1</sup> Developed by the Expert Committee for revision of MSWM manual (2013-15)

<sup>2</sup> Ibid.

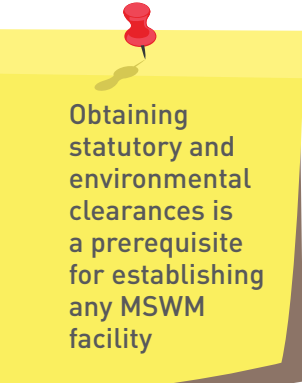

Obtaining statutory and environmental clearances is a prerequisite for establishing any MSWM facility

## 5.1 OBTAINING STATUTORY CLEARANCES FOR MUNICIPAL SOLID WASTE MANAGEMENT FACILITIES

MSWM processing, treatment, and disposal facilities require legal or statutory clearances and approvals for their establishment, depending on the type of facility to be created. SWM Rules, 2016 and the Environmental Impact Assessment (EIA) Notification, 2006 of the Ministry of Environment & Forests and Climate Change (MoEFCC) provide guidance on the statutory requirements for establishing storage, processing, treatment, and disposal facilities.

As per SWM Rules, 2016:



**Clause 15: Duties and responsibilities of local authorities:**

- (y) make an application in Form-I for grant of authorisation for setting up waste processing, treatment or disposal facility, if the volume of waste is exceeding five metric tones per day including sanitary landfills from the State Pollution Control Board or the Pollution Control Committee, as the case may be;
- (z) submit application for renewal of authorisation at least sixty days before the expiry of the validity of authorisation;



**Clause 21: Criteria for waste to energy process:**

- (3) The local body or an operator of facility or an agency designated by them proposing to set up waste to energy plant of more than five tones per day processing capacity shall submit an application in Form-I to the State Pollution Control Board or Pollution Control Committee, as the case may be, for authorisation.
- (4) The State Pollution Control Board or Pollution Control Committee, on receiving such application for setting up waste to energy facility, shall examine the same and grant permission within sixty days.

As per Schedule I of the EIA Notification, 2006, the municipal solid waste (MSW) handling, storage, treatment, and disposal activities fall under the items of 7(d) and 7(i) and require clearance from the State Level Environment Impact Assessment Authority (SEIAA).

An indicative list of clearances and approvals to be obtained are given in the box below:



**An Indicative List of Statutory Clearances or Applicable Acts and Non-statutory Approvals Required by all Municipal Solid Waste Management Processing, Treatment, and Disposal Facilities**

**Statutory Clearances**

- Environmental Clearances: The Water (Prevention and Control of Pollution) Act, 1974; The Water (Prevention and Control of Pollution) Cess Act, 1977; The Air (Prevention and Control of Pollution) Act, 1981; The Environment (Protection) Act, 1986, and Rules; Environmental Impact Assessment (EIA) Rules, 2006
- Clearance from the State Pollution Control Board (SPCB)- “consent to establish” and “consent to operate”
- Clearance from Airport Authority
- Fertilizer Control Order (FCO) Clearance for compost based plants
- Land use from the Revenue Authority
- State Electricity Authority Clearance for providing grid connectivity
- The Public Liability Insurance Act, 1991 and Rules, 1991
- The Industries (Development and Regulation) Act, 1951
- The Factories Act, 1948
- The Motor Vehicles Act, 1938, amended in 1988 and Rules, 1989
- The Petroleum Act, 1934
- The Energy Conservation Act, 2001

**Non-statutory Approvals**

- Proof of Possession of Site
- Bank Loan Sanction Letter and Agreement
- Bank Appraisal Note
- Water Supply Agreement
- Power Purchase Agreement
- Municipal Solid Waste Supply Agreement with Municipal Authority

### **5.1.1 IDENTIFICATION OF LAND FOR MUNICIPAL SOLID WASTE MANAGEMENT PROCESSING, TREATMENT AND DISPOSAL – PRELIMINARY ENVIRONMENTAL ASSESSMENT**

Suitable, encumbrance-free land within the ULB’s jurisdiction should be identified for locating waste processing and treatment facilities. The requirement of land is to be calculated based on a tentative assessment of possible disposal options available to the ULB. The identified land should be checked for environmental compliance.



As per SWM Rules, 2016:

**Clause 19: Criteria for duties regarding setting-up solid waste processing and treatment facility.-**

(1) The department in- charge of the allocation of land assignment shall be responsible for providing suitable land for setting up of the solid waste processing and treatment facilities and notify such sites by the State Government or Union territory Administration.

Schedule 1A criteria for site selection:

(i) The department in the business allocation of land assignment shall provide suitable site for setting up of the solid waste processing and treatment facilities and notify such sites.

(viii) The sites for landfill and processing and disposal of solid waste shall be incorporated in the Town Planning Department's land-use plans.

The following aspects should be evaluated at a minimum:

- location with respect to buffer area requirements as indicated in Section 1.4.5.11 and 4.1 of Part II;
- land terrain characteristics;
- site hydrogeological status; and
- groundwater and ambient air quality.

Land clearance from concerned authorities for establishment of MSWM facilities is to be obtained by the ULB at the earliest possible instance.

## 5.1.2 ENVIRONMENTAL IMPACT ASSESSMENT REQUIREMENTS FOR MUNICIPAL SOLID WASTE MANAGEMENT FACILITIES

EIA Notification, 2006 has divided all infrastructure projects or activities into two categories—Category A and Category B based on the spatial extent and potential impacts on human health, natural, and manmade resources. Category B projects are further divided into B1 and B2 based on requirement of conducting and submitting an EIA report and conducting a public consultation as decided by the State Expert Appraisal Committee (SEAC) at the project screening stage. Category B1 projects are required to submit an EIA report to the SEAC prior to establishing the facility and consent has to be obtained from the SEAC.<sup>3</sup> B2 category projects do not require an EIA clearance. For categorisation of projects into B1 or B2, the MoEFCC shall issue guidelines from time to time.

3 For more details, please refer to EIA Notification, 2006.

Infrastructure projects are divided into two categories: A & B based on their spatial extent and potential impacts on human health and environment

Common MSWM facilities are usually considered Category B projects, unless they fall partially or fully within 10 km from the stipulated eco-sensitive areas or other critical areas



All common MSWM facilities are considered Category B projects. However, facilities are considered Category A projects if they are located wholly or partially within 10 km from the boundary of following:

- wildlife reserves or protected areas (under The Wildlife Protection Act, 1972);
- critical polluted areas identified by the Central Pollution Control Board (CPCB);
- eco-sensitive areas as notified under Section 3 of the Environment (Protection) Act, 1986;
- interstate boundary (this will not be applicable if states or union territories allow project setup in their land); and
- international boundary.

All MSW projects that deal with capping of existing dumpsites and capture of landfill gases for power generation fall under Category B, as defined by the EIA Notification.

The draft EIA notification issued in January 2009 (as an amendment to EIA Notification, 2006) suggests categorisation of the following thermal power plants based on non-hazardous MSW as fuel:

- Category A: greater than or equal to 20 megawatts (MW)
- Category B: less than 20 MW and greater than 15 MW

Power plants upto 15 MW based on non-hazardous municipal waste and using auxiliary fuel such as coal, lignite and petroleum products upto 15% are exempted from EIA requirements.

Projects involving capping of existing dumpsites or capture of landfill gas for power generation are designated as Category B projects

Power plants up to 15 MW based on non-hazardous MSW are exempt from EIA requirements

**Figure 5.2: Environmental Impact Assessment Clearance Requirements for Municipal Solid Waste Management Projects<sup>4</sup>**

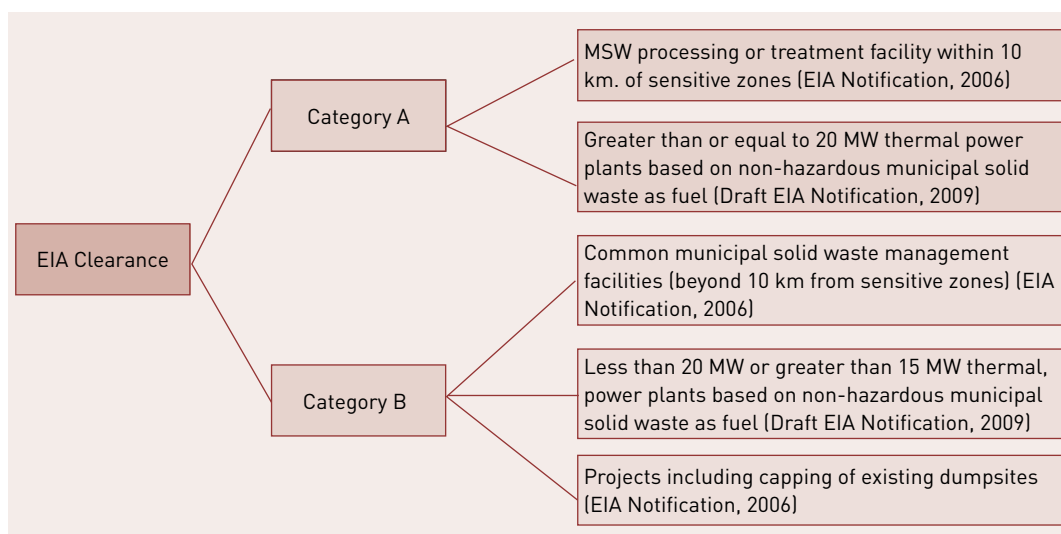

4 Adapted from Environmental Impact Assessment Notification 2006, MoEFCC

### 5.1.2.1 ROLES AND RESPONSIBILITIES OF STAKEHOLDERS INVOLVED IN ENVIRONMENTAL IMPACT ASSESSMENT (EIA)

The environmental clearance process involves many stakeholders such as the Central government, State government, State Level Environment Impact Assessment Authority (SEIAA), Expert Appraisal Committee (EAC), State Level Expert Appraisal Committee (SEAC), State Pollution Control Board (SPCB), etc.

The roles and responsibilities of SEIAA and SEAC involved in EIA are briefly discussed below:

- SEIAA is constituted by the MoEFCC based on the state's recommendation, which makes a final decision regarding acceptance or rejection of environmental clearance for all Category B projects. SEIAA shall receive application from the project proponent, communicate SEAC's views for finalising the ToR, upload the EIA report to their website in cases of Category B projects and shall take a final decision regarding the project clearance.
- EAC or SEAC is a multi-disciplinary independent committee (at the centre and state or union territory level) which reviews each developmental activity and offers its recommendations for consideration of the central government and SEIAA respectively. EAC or SEAC reviews Form 1 of the EIA Notification, 2006 and its attachments, undertakes site visits if necessary to finalize scoping and the ToR, and reviews updated EIA and environmental management plan (EMP) reports.



Stages at which SEAC is consulted:

- Screening
- Scoping
- Appraisal and clearance

### 5.1.2.2 PROCEDURE FOR ENVIRONMENTAL IMPACT ASSESSMENT (EIA) CLEARANCE

All MSW project proponents (ULBs and private contractors) should follow the steps laid out in the EIA Notification, 2006 and its amendments as shown in Figure 5.3.

The entire environment clearance process consists of five stages:

1. Screening
2. Scoping
3. EIA
4. Public consultation
5. Appraisal



However, all these stages might not be required in some cases.

### Screening

Screening is a process of categorising the project into A or B, and into B1 or B2 under Category B.

### Scoping

Potential environmental and health-related impacts of the proposed facility are assessed during this phase. Results of the scoping exercise shall also be used to:

- identify alternative project designs or sites,
- obtain local knowledge of site and surroundings, and
- prepare a plan for public or community involvement.

The scoping will further support preparation of the ToR for the EIA. The SEAC determines the ToR to ensure that all environmental concerns will be addressed in the EIA report.

The EAC or SEAC is the final appraising authority with powers to stipulate further improvements, where required, for final consent or rejection by SEIAA. The EAC or SEAC scrutinizes all the application and documents submitted during the environment clearance process and decides on whether the project is to be granted a clearance and, if so, specifies the conditions for the clearance. Where the proposed project is deemed to impact the environment without scope for due remedies, environment clearance may be denied by the EAC or SEAC.

### Environmental Impact Assessment

EIA is a detailed multistage process to identify and quantify specific impacts of the proposed project on the environment or ecosystem. Public consultation is an important step in the EIA approval process. Concerns of locally affected people and others who have a plausible stake in the environmental impacts of the project or activity are solicited. These concerns are to be addressed in the project's EMP.

Figure 5.3 illustrates the sequence of steps for conducting an EIA to obtain environment clearance.



Stages at which SEIAA is consulted:

- Screening
- Scoping
- EIA report & public hearing
- Appraisal and clearance

Figure 5.3: Steps for Conducting an Environment Impact Assessment (EIA)<sup>5</sup>

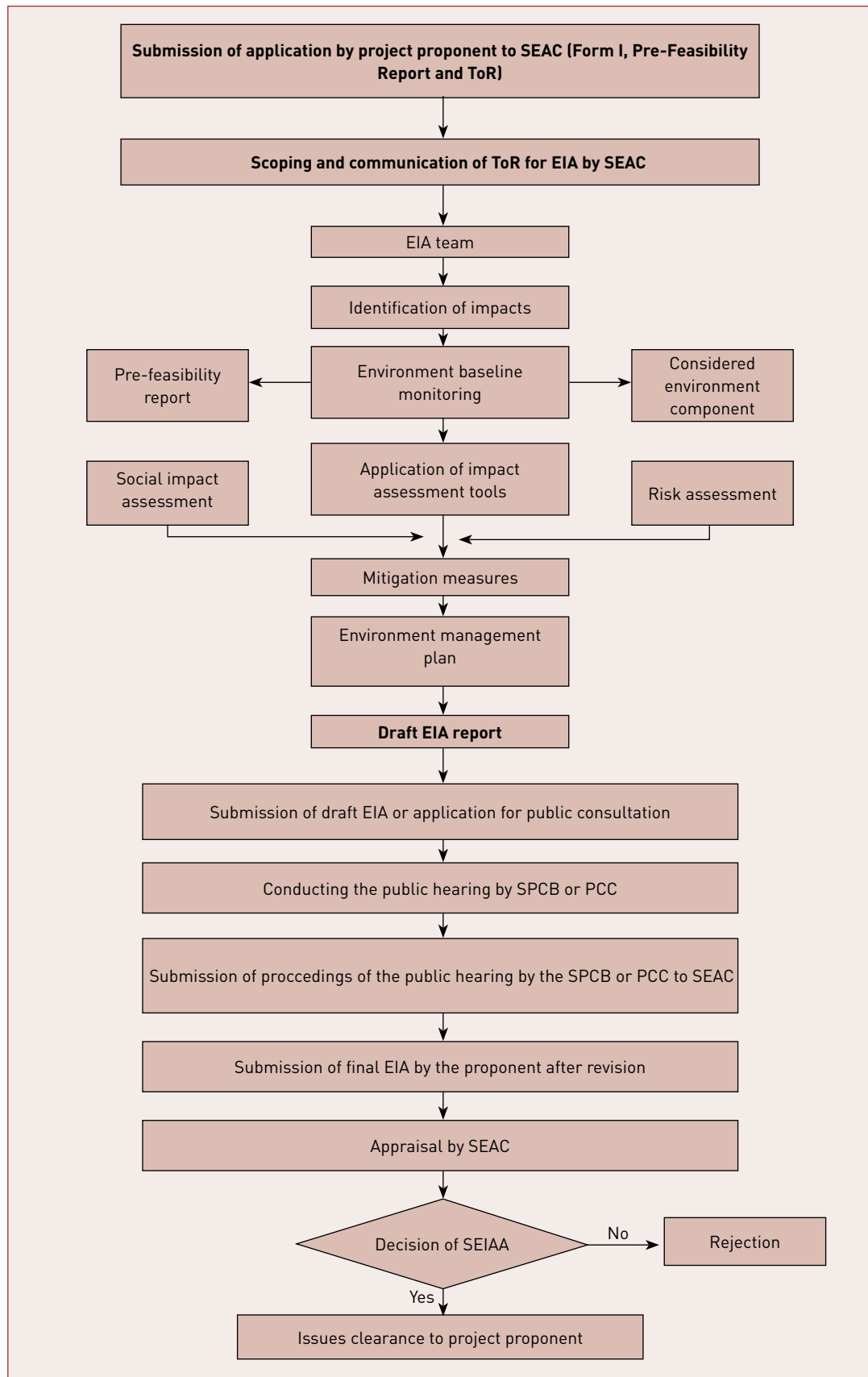

5 Adapted from Technical EIA Guidance Manual for Common Municipal Solid Waste Management Facility, Infrastructure Leasing & Financial Services (IL&FS) (2010).

The scope of the environment baseline monitoring is defined by the ToR approved by the SEAC. The impacts of the proposed facility are superimposed over the baseline scenario to assess the actual impacts on the receptors. Identification of appropriate mitigation measures is a key output of the EIA process. Mitigation of environmental impacts is central in achieving an environmentally sound design (Figure 5.4).

**Figure 5.4: Hierarchy of Environmental Impact Mitigation Options**

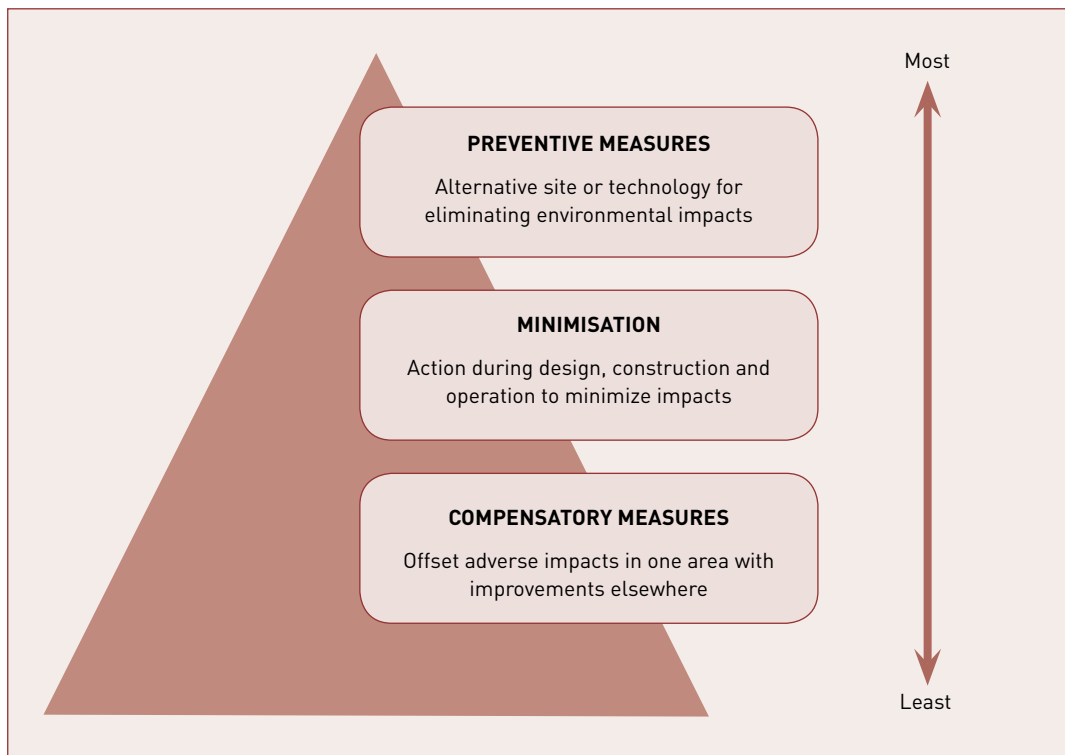

Identified environmental impacts and proposed mitigation measures constitute the EMP. The final EIA report addresses environment baseline conditions, potential impacts, and sets of mitigation measures for the proposed project.

## **5.2 PREPARATION OF ACTION PLANS AND DETAILED PROJECT REPORTS**

The five year short term plan should be further detailed into task specific actions plans (e.g., road sweeping and transportation for service provision) or detailed project reports (DPRs) for major infrastructure related services such as transfer stations, processing or treatment facilities, and scientific waste disposal facilities.

## 5.2.1 ACTION PLANS FOR MUNICIPAL SOLID WASTE MANAGEMENT SERVICE PROVISION

Action plans for specific services should address the following:

- nature of service provided;
- level of service provision like duration of service provision, staffing requirement, equipment requirement, and timings;
- mode of service delivery—whether the service is to be provided by the ULB staff or staff contracted by the ULB, and whether the service is through public private partnership (PPP) mode or private sector participation (PSP) mode;
- contractual obligations, if any;
- cost estimates to the ULB, private entity, or contractor; and
- details of land allocation and the statutory and non-statutory clearances required.

Based on the provisions of the action plans, the ULB should determine the future course of action for enabling service provision.

## 5.2.2 ASSESSMENT OF SUITABILITY OF PROJECTS FOR IMPLEMENTATION THROUGH PUBLIC PRIVATE PARTNERSHIP MODE

The ULB will have to decide whether specific projects requiring considerable capital costs, long design life, and complex operational and management systems are suited for implementation through the PPP mode or through the ULB's own resources.

A pre-feasibility study is recommended to help analyse the suitability of projects for PPP mode. It would provide recommendations on all public or private options that would be available for project implementation. A pre-feasibility study would address the aspects given in Table 5.2.

Suitability of MSWM projects for implementation through PPP mode should be ascertained through pre-feasibility and feasibility studies

Table 5.2: Indicative Contents for Pre-Feasibility Study<sup>6</sup>

| S.NO | CONTENT  |
|------|--|
| 1.   | <b>Preliminary Analysis of Technical and Operational Practicality of the Project</b> |
|      | 1.1. Engineering and technical aspects of the project                                |
|      | Manageability of operational aspects of the project                                  |
|      | Preliminary assessment of all likely technical and operational risks                 |
| 2.   | <b>Environmental and Social Safeguard Activities</b>                                 |
|      | 2.1 Socio-economic assessment and analysis   |
|      | 2.2 Environmental assessment scoping   |

<sup>6</sup> Draft National Public Private Partnership Policy (2011). Department of Economic Affairs. Government of India. Available at: <http://toolkit.pppinindia.com/solid-waste-management/module2-pfcaa-ppfa.php?links=pfcaa1b>.

**Table 5.2: Indicative Contents for Pre-Feasibility Study [contd.]**

|           |  |   |
|-----------|--|---|
| <b>3.</b> | <b>Preliminary Assessment of Financial and Economic Viability of the Project</b> |   |
|           | 3.1  | Cost recovery or income generation assumptions of the project                               |
|           | 3.2  | Likely private sector interest in the project   |
|           | 3.3  | Overall project cost (capital + operations + maintenance)                                   |
|           | 3.4  | Possible financial risks  |
|           | 3.5  | Identification of likely economic benefits generated by the project                         |
| <b>4.</b> | <b>Possible Arrangements for Private Sector Participation (PSP)</b>              |   |
|           | 4.1  | Role of the private sector  |
|           | 4.2  | Contractual framework for the PSP arrangement   |
|           | 4.3  | Outlined procedure for ensuring competition in the selection of the private sector partners |
|           | 4.4  | Legal documentation required to allow participation of the private sector                   |
| <b>5.</b> | <b>Next Steps</b>  |   |
|           | 5.1  | Resources required to complete project preparation  |
|           | 5.2  | Parties responsible for completing next steps   |
|           | 5.3  | Roles and responsibilities of involved parties  |
|           | 5.4  | Time frame for completing project preparation   |

**Figure 5.5: Public Private Partnerships – Stages of Implementation.<sup>7</sup>**

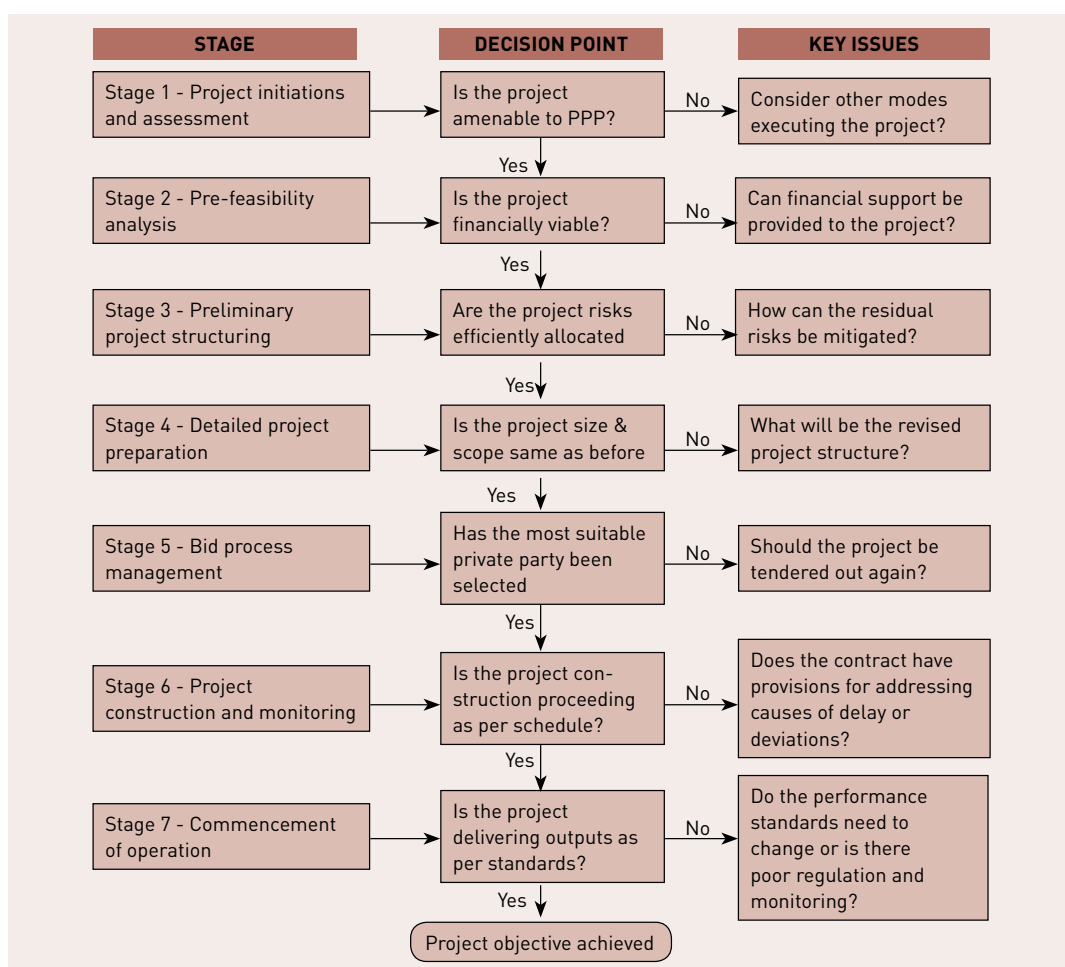

<sup>7</sup> Toolkit for Solid Waste Management, Jawaharlal Nehru National Urban Renewal Mission, Ministry of Urban Development, Government of India. <http://jnurm.nic.in/wp-content/uploads/2012/11/SWM-toolkit.pdf>

The outcomes of a pre-feasibility study would determine whether the project is suitable for implementation through PPP mode or through the ULB's own resources. If at the pre-feasibility stage it is decided that the project has to be undertaken in a PPP mode, the next step is to conduct a feasibility study to ascertain the broad structure of the PPP project. The information from a feasibility study can then be used to prepare bidding documents.

Generic aspects to be addressed by a feasibility study include the following:<sup>8</sup>

- **Market analysis and project scope:** This is to assess the appropriate scope of the project, building on the work already done at the strategic planning and pre-feasibility stage. This would include the following:
  - Needs analysis - Does the project meet an end-user need? Does it contribute to meeting the objectives of the sponsoring authority? Who will the users be?
  - Options analysis - What is the best option for meeting the service need: a no-asset solution, existing assets, or new assets?
  - Output definition - What services will the project provide?
  - Demand estimate and forecast - What level of demand is there for the outputs or services from the project, and how much are users willing to pay?
- **Social and environmental feasibility:** This includes the requirements for impact assessments and for associated mitigation.
- **Technical feasibility and technical parameters:** These are based on the market analysis and include specification of required facilities and scenarios of project size for use in preliminary project design.
- **Risk studies and refined public private partnership mode:** These include assessment of the risks associated with the project, study of which party is best able to bear each risk, and refinement of the PPP mode selected at the pre-feasibility stage.
- **Preliminary cost assessment:** This is within a  $\pm 5\%$  range based on the technical specification and assessed project risks.
- **Financial analysis and due diligence:** These include incorporating a projected revenue structure (e.g., proposed tariff, required annuity) and assessing any need for financial support from the public sector.
- **Economic feasibility:** This includes an assessment of overall net economic benefits of the project, incorporating estimated project benefits and costs including non-market factors such as those from the social and environmental assessment.

8 Draft National Public Private Partnership Policy (2011), Department of Economic Affairs, Ministry of Finance, Government of India. <http://toolkit.pppinindia.com/solid-waste-management/module2-pfcaa-ppfa.php?links=pfcaa1b>

- **Other public private partnership due diligence activities:** This includes value for money or value addition analysis if data is available.
- **Project implementation schedule:** This includes an outline of the proposed PPP procurement and award process through technical and financial closure, an outline of the construction schedule and target operation date, and any phasing that is planned for project extensions or ongoing development.



While carrying out a feasibility study it is also important to consider these provisions as prescribed under SWM Rules, 2016:

Clause 7a) provide market development assistance on city compost

b) ensure promotion of co-marketing of compost with chemical fertilizer in the ratio of 3 to 4 bags: 6 to 7 bags by the fertilizer companies to the extent compost is made available for marketing to the companies.

Clause 8(a) provide flexibility in the fertilizer control order for manufacturing and sale of compost propagate utilisation of compost on farm land.

Clause 9(a) decide tariff or charges for the power generated from the waste to energy plants based on solid waste.

(b) compulsory purchase power generated from such waste to energy plants by distribution company.

Clause 21. Criteria for waste to energy process.-

(1) Non recyclable waste having calorific value of 1500 K/cal/kg or more shall not be disposed of on landfills and shall only be utilised for generating energy either or through refuse derived fuel or by giving away as feed stock for preparing refuse derived fuel.

(2) High calorific wastes shall be used for co-processing in cement or thermal power plants.

Based on inputs from the pre-feasibility or feasibility reports, the ULB should decide whether to pursue the PPP route or the PSP route for project implementation. Information from these reports is used to define a well-structured bid. Selected private operators are then responsible for preparing a detailed project report (DPR) for further approval by the designated authorities. Where the project is found unsuitable for a PPP, PSP may be called for. Private entities are also required to prepare a DPR on the proposed implementation. Figure 5.6 depicts the process for determining suitability of projects for PPP mode.

**Figure 5.6: Process for Determining Suitability of Projects for Public Private Partnership Implementation**

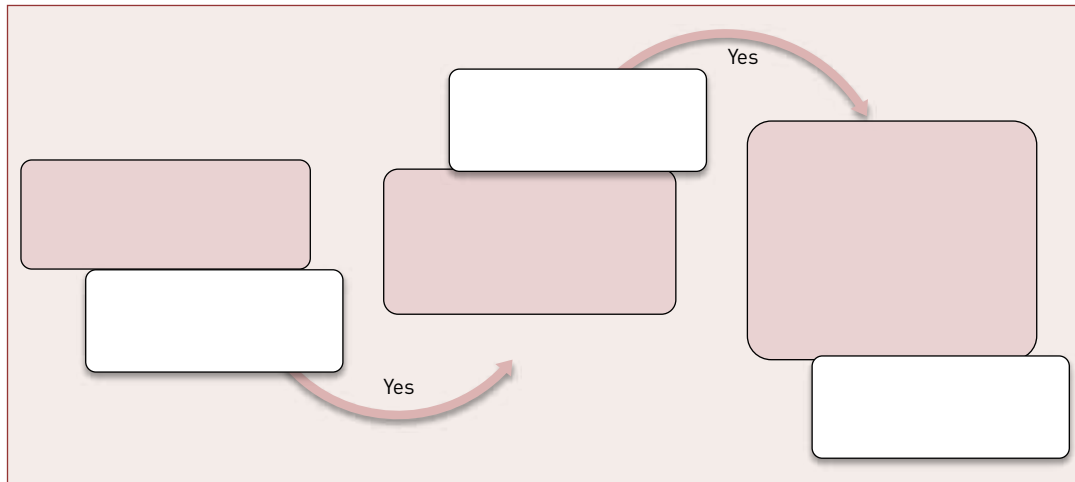

### 5.2.3 DETAILED PROJECT REPORTS FOR INFRASTRUCTURE BASED PROJECTS

All infrastructure based facilities require the preparation of a DPR with sufficient details to ensure appraisal, approval, and subsequent implementation of the project in a timely and efficient manner. The major sections that should be covered in a DPR are:

- sector background, context, and broad project rationale;
- project definition, concept, and scope;
- institutional framework for implementation;
- resource requirements – land, capital, machinery, and staffing;
- project cost – lifecycle cost assessment;
- financial structuring;
- project phasing;
- operation and maintenance (O&M) framework and financial implication;
- project financial viability;
- project sustainability – social and environmental; and
- project benefits assessment – environmental and socio-economic benefits, resource intensity, etc.

Additional details can be incorporated as per the requirements of the ULBs. An indicative checklist for DPRs is listed in Table 5.3. Subsequent sections of this chapter address specific issues that would facilitate the implementation of the short term MSWM plan.



**Table 5.3: Indicative Checklist for a Detailed Project Report<sup>9</sup>**

|           |  |   |
|-----------|--|---|
| <b>1.</b> | <b>INTRODUCTION TO THE PROJECT (EXECUTIVE SUMMARY)</b> |   |
|           | 1.1  | Definition of MSWM  |
|           | 1.2  | Status and issues of MSWM   |
|           | 1.3  | Provisions of MSWM plan – long term and short term                      |
|           | 1.4  | Project background and link to the MSWM plan                            |
|           | 1.5  | Project formulation justification (need for the project)                |
| <b>2.</b> | <b>CITY PROFILE (DETAILED DATA OF WARDS OR ZONES)</b>  |   |
|           | 2.1  | History and importance of the project town                              |
|           | 2.2  | Geographical and climatic conditions                                    |
|           | 2.3  | Location and extent   |
|           | 2.4  | Population  |
|           | 2.4.1  | Population projections  |
|           | 2.4.2  | Population density  |
|           | 2.4.3  | Floating Population   |
|           | 2.5  | Settlements in city   |
|           | 2.5.1  | Number of households, shops, commercial establishments and institutions |
|           | 2.5.2  | Number of hotels, restaurants, banquet halls                            |
|           | 2.5.3  | Number of large markets (vegetables, meat and fish)                     |
|           | 2.5.4  | Slums and other informal settlements                                    |
|           | 2.5.5  | Industries and their profile  |
|           | 2.5.6  | Health care establishments  |
|           | 2.5.7  | Slaughterhouses   |
|           | 2.6  | Land use plan   |
|           | 2.7  | Physical infrastructure   |
|           | 2.7.1  | Roads   |
|           | 2.7.2  | Storm water management  |
|           | 2.7.3  | Sewage management   |
|           | 2.7.4  | Water Supply System   |
|           | 2.7.5  | Electricity   |
|           | 2.8  | Urban economy   |
|           | 2.9  | Information about ULB   |
|           | 2.9.1  | Political Setup   |
|           | 2.9.2  | Administrative setup of ULB   |
|           | 2.9.3  | Administrative setup of Sanitation Department of the ULB                |
|           | 2.9.4  | Financial status of ULB   |
|           | 2.9.5  | Administrative and financial aspects of MSWM                            |

<sup>9</sup> Developed by the Expert Committee for revision of MSWM manual (2013-15)

**Table 5.3: Indicative Check-list for a Detailed Project Report [contd.]**

| <b>3 STATUS OF EXISTING SOLID WASTE MANAGEMENT IN THE CITY</b> |  |
|--|--|
| 3.1  | Waste generation(based on actual sample survey)          |
| 3.1.1  | Approach adopted for estimation of waste generation      |
| 3.1.2  | Residential areas –colonies, apartment complexes         |
| 3.1.3  | Commercial establishments, malls                         |
| 3.1.4  | Hotels, restaurants, banquet hall                        |
| 3.1.5  | Institutional areas- offices, schools, universities      |
| 3.1.6  | Fruit and vegetable markets, fish and meat markets       |
| 3.1.7  | Hospitals and nursing homes (excluding biomedical waste) |
| 3.1.8  | Slaughterhouses  |
| 3.2  | Quantification and characterization of waste             |
| 3.2.1  | Sampling criteria  |
| 3.2.2.   | Physicochemical characteristic of MSW                    |
| 3.3  | Existing MSW collection system                           |
| 3.3.1  | Primary waste collection system                          |
| 3.3.2  | Primary Waste Storage at Generation                      |
| 3.3.3  | Secondary waste collection system                        |
| 3.4  | Street sweeping and drain cleaning                       |
| 3.5  | MSW secondary storage system                             |
| 3.5.1  | Transfer Station Details                                 |
| 3.5.2  | Waste Storage Depots                                     |
| 3.6  | MSW transportation system                                |
| 3.7  | Existing MSW processing system                           |
| 3.7.1  | Recyclable Waste   |
| 3.7.2  | Biodegradable Waste                                      |
| 3.7.3  | Non-biodegradable waste                                  |
| 3.7.4  | Construction and Demolition Waste                        |
| 3.7.5  | Any Other Waste (Domestic Hazardous, sanitary waste)     |
| 3.8  | Infrastructure existing for SWM                          |
| 3.8.1  | Manpower   |
| 3.8.2  | Equipment/Vehicles                                       |
| 3.8.3  | Equipment repair facility                                |
| 3.9  | Status of present disposal and proposed landfill site    |
| 3.10   | Overall compliance of SWM Rules                          |
| <b>4. PROJECT DEFINITION</b>                                   |  |
| 4.1  | Project objectives                                       |
| 4.2  | Scope of project   |
| 4.3  | Approach and methodology                                 |

Private sector participation is beneficial especially in newly developed areas and underserved areas, where the ULB has not been providing services through its own labour force

**Table 5.3: Indicative Check-list for a Detailed Project Report [contd.]**

|           |   |  |
|-----------|---|--|
| <b>5</b>  | <b>GAP ANALYSIS</b>                                     |  |
|           | 5.1   | Manpower and Vehicle requirement for door to door collection, street sweeping and drain cleaning |
|           | 5.2   | Sufficiency of Secondary Collection Bins   |
|           | 5.3   | Sufficiency of Secondary Collection Vehicles   |
|           | 5.4   | Sufficiency in treatment, processing & disposal facilities                                       |
|           | 5.5   | Gaps in Awareness among city residents and civic authorities                                     |
|           | 5.6   | Gaps in Institutional Structure  |
|           | 5.7   | Gaps in Capacity Building for ULB  |
| <b>6.</b> | <b>PROPOSED MUNICIPAL SOLID WASTE MANAGEMENT SYSTEM</b> |  |
|           | 6.1   | Segregated Storage of Waste at Source  |
|           | 6.2   | Street Sweeping and Drain Cleaning   |
|           | 6.3   | Segregated Waste Collection  |
|           | 6.4   | Segregated MSW Transport system and Secondary Collection   |
|           | 6.5   | Transfer Station if required, as per SWM Rules 2016  |
|           | 6.6   | Processing of MSW  |
|           | 6.6.1   | Criteria for selection of processing technology  |
|           | 6.6.2   | Availability of land   |
|           | 6.6.3   | Process design for proposed processing plant   |
|           | 6.6.4   | Design of processing plant and leachate management   |
|           | 6.6.5   | Required infrastructure and equipment  |
|           | 6.6.6   | Environmental Monitoring and control   |
|           | 6.6.7   | Socio-economic Benefits  |
|           | 6.6.8   | Product Utilisation  |
|           | 6.7   | Municipal sanitary landfill  |
|           | 6.7.1   | Conceptual design of landfill  |
|           | 6.7.2   | Availability of land   |
|           | 6.7.3   | Technical specification  |
|           | 6.7.4   | Environmental monitoring and control   |
|           | 6.7.5   | Socio-economic benefits  |
|           | 6.7.6   | Biomining and Bioremediation plan for existing dumpsites   |
|           | 6.7.7   | Capping old dumpsites  |
|           | 6.8   | Staffing Requirements  |
|           | 6.9   | Community Awareness and Public Participation   |
|           | 6.9.1   | Overview   |
|           | 6.9.2   | Objective  |
|           | 6.9.3   | Public Participation and awareness through IEC programs  |
|           | 6.9.4   | Project Implementation Plan  |

**Table 5.3: Indicative Check-list for a Detailed Project Report [contd.]**

|           |   |  |
|-----------|---|--|
| <b>7</b>  | <b>INSTITUTIONAL ASPECTS AND CAPACITY BUILDING</b>  |  |
|           | 7.1   | Proposed organizational setup  |
|           | 7.2   | Training and capacity building of ULB  |
| <b>8</b>  | <b>OTHER O&amp;M ASPECTS</b>                        |  |
|           | 8.1   | Management Information System  |
|           | 8.2   | Complaint Handling System  |
|           | 8.3   | Environmental Health and Safety Aspects  |
| <b>9</b>  | <b>COMMUNITY AWARENESS AND PUBLIC PARTICIPATION</b> |  |
|           | 9.1   | Overview   |
|           | 9.2   | Objective  |
|           | 9.3   | Public Participation and awareness through IEC programs                          |
|           | 9.4   | Project Implementation Plan  |
| <b>10</b> | <b>COST ESTIMATES</b>                               |  |
|           | 10.1  | Cost Estimates for Collection and Transportation                                 |
|           | 10.1.1  | Capital Expenditure  |
|           | 10.1.2  | O&M Expenditure  |
|           | 10.2  | Cost Estimates for Processing and Disposal                                       |
|           | 10.2.1  | Capital Expenditure  |
|           | 10.2.2  | O&M Expenditure  |
|           | 10.3  | Total Revenues Generated   |
|           | 10.3.1  | Operation and Maintenance cost and revenue generation from residents, apartments |
|           | 10.3.2  | Proposed Tariff Charges  |
|           | 10.3.3  | Revenue from Sale of Products  |
|           | 10.3.4  | Revenue from User Charges  |
| <b>11</b> | <b>FINANCIAL ASPECTS</b>                            |  |
|           | 11.1  | Current MSW Expenditure  |
|           | 11.2  | Project financial structuring including PPP Decisions                            |
|           | 11.3  | Funds for capital expenditure  |
|           | 11.4  | Possibilities for cost sharing   |
|           | 11.5  | Finance for operation & management   |
|           | <b>ANNEXURE</b>                                     |  |



### **Adequate Service Provisions for Waste Processing, Treatment and Disposal Facilities**

- Provision of good quality or metalled access road leading to the processing or treatment and disposal facility
- Adequate power supply for carrying out the day to day activities in the plant
- Adequate supply of drinking water for the staff
- Adequate provision of storm water management at the plant site
- Adequate provision of toilets for male and female staff. Adequate sewerage disposal system for smooth functioning and operation of the plant. However, in absence of the sewer line, onsite sewer system should be provided.

## **5.3 CONSIDERATIONS FOR CONTRACTING A MUNICIPAL SOLID WASTE MANAGEMENT SERVICE**

Following essential aspects may be considered by the ULB while deciding to contract out municipal solid waste management services:

- The ULB should identify services that can be effectively provided by the existing staff and available financial resources.
- Subsequently, services which would need to be outsourced due to limited in-house technical know-how, capability, and financial resources should be identified.
- Benefits and potential issues with outsourcing services which the ULB cannot provide (as identified above) should be fully evaluated and understood. Justification note for the need to contract out identified services should be prepared.
- Commercial or economical feasibility of the services to be contracted out has to be ascertained. The appropriate contract models and their benefits need to be assessed for each of the services that has to be contracted out.
- Where contract labour is hired, the ULB should ensure compliance with the provisions of the Contract Labour (Regulation & Abolition) Act, 1970.
- Sharing of all possible risks (technical, operational, and financial) between ULB and the operator should be detailed out.
- Where land acquisition or community rehabilitation is involved, the ULB has to stand in for the contractor in addressing such aspects.
- Contracts should specify the range of technology or technologies that can be adopted after the ULB undertakes a thorough assessment of available technologies for specific services.

- In ULBs with population of over 1 lakh, at least two contractors may be considered for every outsourced service. However, this is not relevant for processing and treatment facilities in small and medium towns.
- For cities with more than 10 lakh population, ULBs should prepare a feasibility report for the services or projects to be contracted. Depending on the feasibility report, the ULB should prepare a DPR including the detailed engineering report for minimising risks associated with the project. Cities with less than 10 lakh population may directly prepare a DPR to minimize costs associated with the feasibility study, provided the project can be appropriately defined. The ToR for the services to be contracted should be based on the DPR developed.
- On ascertaining the benefit of outsourcing services, the ULB shall prepare a ToR which shall include at least the following:
  - detailed description of scope of work;
  - specific outcomes or outputs of the services and performance standards for the services to be contracted;
  - specified duration of the service to be contracted and time lines for project execution or provision of services;
  - minimum qualification and experience of the bidder required for plan of work and methodology;
  - minimum staffing and equipment required for delivering the services;
  - envisaged monitoring and evaluation requirements;
  - management structure and reporting;
  - tender evaluation procedure;
  - payment mechanism;
  - adequate social and environmental safeguards to ensure equitable service provision;
  - confidentiality clause; and
  - service level guarantee mechanisms.



### Pre-requisites for Contracting

- Cost benefit analysis of the existing solid waste management system is necessary.
- Services to be outsourced shall be identified.
- Characterisation and physicochemical analysis of municipal waste should precede tendering of any waste processing, treatment, and disposal facilities.
- Detailed project development is the key to successful implementation. Detailed project definition and key performance indicators have to be established.
- Land requirement for 20–25 years for proposed facilities shall be assessed and identified.
- Complete ownership of all projects by the ULB (not just ownership of property, but active commitment and monitoring) is crucial.

An overview of different kind of contracts specific to different MSWM services and their characteristics are given in Section 1.4.5.7 of Part II.

### 5.3.1 CONTRACTING ARRANGEMENTS FOR MUNICIPAL SOLID WASTE SERVICE PROVISION

Not all contracting models are suitable for each of the MSWM operations. Municipal authorities may adopt one or more of the following contracting models:

- Service contract (door-to-door collection and transportation of waste)
- Management contract (door-to-door collection, construction and demolition [C&D] waste collection, secondary storage, and transportation of waste)
- Build and transfer (transfer station, sanitary landfill)
- Build-Operate-Transfer (BOT) (biomethanation, composting, sanitary landfill)
- Build-Own-Operate (BOO) (composting, refuse derived fuel [RDF], incineration)
- Design-Build-Own-Operate-Transfer (DBOOT) (large compost plants, RDF plants, incineration, and sanitary landfill)
- Design-Build-Finance-Operate-Transfer (DBFOT) (large compost plants, RDF plants, incineration, and sanitary landfill)

ULBs may decide to bundle certain services while contracting out MSWM operations to build accountability and efficiency in the system. Table 5.4 indicates a typical mix of services that are bundled and the most relevant contracting models for outsourcing these services:

### Contract Models for MSWM Services:

- Service contract
- Management contract
- Design-Built-Operate (DBO)
- Build-Own-Operate (BOO)
- Build-Own-Operate and Transfer (BOOT)
- Build-Operate-Transfer (BOT)
- Lease
- Concession

**Table 5.4: Typical Services Bundled for Contracting**

| S. NO | TYPE OF PROJECT      | DESCRIPTION OF PROJECT   | ADVANTAGES  | RISKS  | UNIT OF MEASUREMENT   |
|-------|----------------------|--|---|--|---|
| 1     | MSWM: Model 1 (ISWM) | This model consists of the following:<br>1. Collection<br>2. Transportation<br>3. Processing<br>4. Sanitary landfill         | 1. It increases accountability of a single party.<br>2. It minimizes hassles among different contractors.<br>3. With a single party responsible for all activities, there is no scope for issues regarding operational or process deficiencies in executing any of the services. Poor performance cannot be blamed on upstream deficiencies or issues of quantity and quality of waste.<br>4. It is easier, more efficient, and less time-consuming for the ULB to deal with a single party for managing all MSWM services. | 1. This creates a monopoly of the contractor and increases the scope for defaults and further negotiations, given that the entire MSWM service chain is in the hands of a single contractor.<br>2. The entire city service may get disrupted if the contractor fails to perform, or in case of any other unforeseen circumstances.<br>3. If the principal contractor off-loads certain services to associates, risks (cost & monitoring) might increase substantially.<br>3. Delay in execution of one service will result in overall system delays.<br>4. There is scope for the contractor to recover full fees though he or she may not perform certain functions on a daily basis. | 1. Quantity of waste collected and transported on a daily basis<br>2. Tonnes of waste received at the processing plant and product produced<br>3. Tonnes of waste landfilled<br>Using only a single monitoring measure as the basis to pay the contractor could be risky and against the interest of the ULB. |
| 2     | MSWM: Model 2        | This model consists of two packages:<br>Package 1: Collection and transportation<br>Package 2: Processing and disposal (P&D) | 1. ULBs can hire suitable agencies that have experience and expertise in distinct areas of MSWM services.<br>2. ULB could also retain package 1 within its own scope and outsource only P&D to specialized agencies.<br>3. Alternately, package 1 can be divided among multiple players (on an area basis), leading to a better control of the waste collection and transportation. The ULB can then depend on any of the operators if one fails to perform.  | Adequate care should be taken to ensure that the collection and transportation of segregated wastes should be regular and in sync with the requirements of the processing facility.  | 1. Package 1: Tonnes of waste collected and transported<br>2. Package 2:<br>i. Tonnes of waste processed per processing plant and product produced<br>ii. Tonnes of waste at disposal facilities  |



Table 5.4: Typical Services Bundled for Contracting [contd.]

| S. NO | TYPE OF PROJECT                       | DESCRIPTION OF PROJECT   | ADVANTAGES  | RISKS   | UNIT OF MEASUREMENT  |
|-------|---------------------------------------|--|---|---|--|
| 3     | MSWM: Model 3                         | This model consists of three packages:<br>Package 1: Collection and transportation<br>Package 2: Processing<br>Package 3: Sanitary landfill  | <ol style="list-style-type: none"> <li>1. ULBs can select agencies having expertise in MSWM service areas at a very competitive rate.</li> <li>2. It provides scope for competition between multiple service providers.</li> <li>3. It does not create a monopoly of a single service provider.</li> <li>4. It enables the ULB to replace a nonperforming contractor without disrupting all other MSWM services</li> </ol>  | Same as above   | <p>Package 1: Tonnes of waste collected and transported</p> <p>Package 2: Tonnes of waste processed per processing plant or product produced</p> <p>Package 3: Tonnes of waste at disposal facilities</p>  |
| 4     | MSWM: Model 4 (decentralised project) | The model has four packages (each process is considered an individual project):<br>Package 1: Collection<br>Package 2: Transportation<br>Package 3: Processing<br>Package 4: Sanitary landfill | <ol style="list-style-type: none"> <li>1. ULB can select agencies having expertise in MSWM service areas at a very competitive rate.</li> <li>2. It provides scope for competition between multiple service providers.</li> <li>3. It does not create a monopoly of a single service provider.</li> <li>4. It enables the ULB to replace a nonperforming contractor without disrupting all other MSWM services.</li> <li>4. Each service can be operated by specific specialists.</li> <li>5. There is scope to ensure provision of cost-effective services due to competition and to replace nonperforming contractors.</li> </ol> | The risk of lack of synchronisation between waste collection and transportation agencies can disrupt overall service provision. This in turn can adversely affect the processing and disposal services. | <p>Package 1: Persons employed or tonnes of waste collected</p> <p>Package 2: Tonnes of waste transported</p> <p>Package 3: Tonnes of waste processed per processing plant and tonnes of product produced, if any</p> <p>Package 4: Tonnes of waste at disposal facilities</p> |

## 5.4 TENDERING, CONTRACT MANAGEMENT AND SUPERVISION

As per SWM Rules, 2016:



Clause 15: Duties and responsibilities of local Authorities:

(v) facilitate construction, operation and maintenance of solid waste processing facilities and associated infrastructure on their own or with private sector participation or through any agency for optimum utilisation of various components of solid waste adopting suitable technology including the following technologies and adhering to the guidelines issued by the Ministry of Urban Development from time to time and standards prescribed by the Central Pollution Control Board.

(w) undertake on their own or through any other agency construction, operation and maintenance of sanitary landfill and associated infrastructure as per Schedule 1 for disposal of residual wastes in a manner prescribed under these rules;

(x) make adequate provision of funds for capital investments as well as operation and maintenance of solid waste management services in the annual budget ensuring that funds for discretionary functions of the local body have been allocated only after meeting the requirement of necessary funds for solid waste management and other obligatory functions of the local body as per these rules;

ULBs may enter into contract with private service providers for provision of specified MSWM services such as collection, transportation, treatment, processing, and disposal of waste (for more details, refer to Section 1.4.5.7 of Part II). Private service providers have to be held accountable for maintaining required standards of services as well as its effectiveness and efficiency.

Adequate care should be taken while preparing tender documents to ensure that only those firms with requisite qualifications and experience are considered. The following aspects should be kept in mind:

- The tender should clearly specify the technical and financial capability required to perform the task proposed to be outsourced. The qualification criteria should be standardized. It should provide equal opportunity to all those who have a capability to undertake the task. It should not restrict competition between big players; at the same time, it should not allow incompetent, inexperienced, or unqualified parties to enter the fray. The eligibility criteria should be limited to what is required to perform the obligation; this shall enhance healthy competition and create a pool of entrepreneurs to provide MSWM services.

Standardise pre-qualification criteria should support only those firms having adequate resources and expertise

- Selection of bidders should be based on technical and financial bids and specified criteria. This could be done in several ways:
  - The ULB may prescribe minimum qualifying standards for technical bids; financial bids of only those bidders who meet the minimum qualifying standard may be opened unless otherwise justified.
  - ULB may give higher weightage to qualifications and experience in cases where higher skills are necessary.
- Awarding contracts to single party covering all aspects of MSWM in the city may be avoided, as it can create unmanageable situation if the contractor ceases to operate. Multiple contracts are desirable so that if one contractor fails, another can take over until other arrangements are made. However, it may not be feasible in case of processing and landfilling.
- A transparent and stringent monitoring and evaluation system should be developed to ensure that contractors perform their obligations.
- Long term contracts should provide for a periodic revision of tariffs based on predetermined parameters and create implementation mechanisms to ensure sustainability of the contract.
- ULBs should ensure timely payments for contracted services.
- ULBs should ensure adequate in-house capabilities for appropriate contract monitoring.

Selection of bidders should be based on both technical and financial criteria

Multiple contracts for MSWM services should be encouraged to ensure duplicate competencies, which can be relied on during times of failure of contractual obligations by any of the contractors



The ULB itself should provide door-to-door collection and transportation of wastes in a few wards in the city to maintain in-house capacity for providing crucial services in times of crisis (e.g., dispute in contract provisions, when the service provider does not discharge his obligations, etc.). Contingency plans should be prepared by the ULB for appropriate storage of waste to tide over situations of non-performance of the processing, treatment, and disposal facilities.

Depending on the project structure and time or cost considerations, ULBs can adopt a single-stage process or a two-stage process for contracting

#### 5.4.1 ENGAGING WITH A PUBLIC PRIVATE PARTNER

After a DPR, a transparent procurement process should be adopted for the selection of a PPP partner, preferably through a transaction advisor, by following these standard procedures:

- Preparation of expression of interest (EoI), request for proposal (RFP), and concessionaire agreement
- Obtaining approval from concerned authority
- Issue of notice for pre-qualification or EOI
- Short-listing of firms
- Issue of RFP to the shortlisted firms
- Conducting pre-bid meeting



Contents of a typical request for qualification (RFQ):

- Introduction
- Instruction to applicants
- Fraud & corrupt practises
- Pre-bid conference
- Miscellaneous

- Receiving technical and financial bids in separate packets in response to the RFP and opening of technical bids
- Evaluation of the technical bid document received
- Opening of financial bids of the bidders (minimum three bids would be desirable)
- Evaluation of financial bids
- Selection of most preferred bidder
- Negotiation and signing of agreement
- Award of contract

## 5.4.2 TENDERING PROCESS FOR PUBLIC PRIVATE PARTNERSHIP PROJECTS

The ULB has an option of adopting a single stage selection process or a two-stage selection process for awarding contracts to the PPP player.

### 5.4.2.1 SINGLE STAGE PROCESS

In a single stage bidding process, technical and financial bids are submitted simultaneously in response to a RFP. The selection of the preferred bidder is envisaged through an evaluation of a three-part proposal received from interested bidders:

- **Part I – Response to qualification:** Pre-qualification will be based on the documents received from bidders in response to the qualifying criteria laid down by the ULB. The technical and financial offers of bidders, who do not qualify at this step, will be returned unopened.
- **Part II – Technical offers:** Technical offers in the proposals from bidders who qualified at the end of first stage will be opened and



#### Indicative Schedule for Bidding: Single Stage Process

- Sale of bid or request for proposal (RFP) to short-listed applicants: zero date
- Submission of query by the perspective applicants: +15 days
- Pre-bid meeting: +20 days
- Authority response to queries: +30 days
- Bid submission due date: +60 days
- Opening of technical bids: +60 days
- Acceptance of technical evaluation report by Tender Committee: +80 days
- Financial bid opening: +90 days
- Letter of intent (LOI): within 30 days of bid opening date
- Issue of letter of award to bidder: +30 days of issue of LOI
- Contract signing: within 30 days of award of LOI

#### Notes:

1. The bidding process takes 4 months minimum. However, depending upon the urgency and requirement of the project execution the bidding process could be done within 60 days.
2. +“x” days means time duration from the zero date, i.e., RFP’s date of publication.

evaluated against predetermined criteria. Financial offers of bidders, who do not qualify at this step, will be returned unopened.

- **Part III – Financial offers:** Financial offers from proposals of those bidders whose technical offers are qualified shall be opened and scrutinized. Only those financial offers which are in accordance with criteria laid down in RFP shall be evaluated.

#### 5.4.2.2 TWO STAGE PROCESS

The two stage selection process is characterised by an initial pre-qualification stage, followed by RFP stage, which is applicable only to pre-qualified bidders.

**Stage 1: Qualification stage:** The request for qualification (RFQ) specifies the minimum qualifications required for participation in the tender. Suitability of interested parties or consortia will be assessed by the tenderer in accordance with the provisions of the RFQ. At the end of this stage, the authority will shortlist suitable pre-qualified applicants who are then eligible for participation in the second stage of the bidding process (the “bid stage”).

**Stage 2: Letter of invitation:** After the bidders have been shortlisted under the RFQ for the aforesaid project, ULB should invite the bidders to procure the RFP with the objective of submitting a technical and financial proposal.



RFQ contains useful information required by bidders for formulating their application for qualification



#### Indicative Schedule for Bidding – Two Stage Process

##### Stage 1: Pre-Qualification Stage (Minimum: 3 months)

- Sale of request for qualification (RFQ): zero date
- Submission of query by the perspective applicants: +15 days
- Pre-bid meeting: +20 days
- Authority response to queries: +30 days
- Bid submission due date: +60 days
- Opening of technical qualification bids: +60 days
- Acceptance of technical qualification evaluation report by Tender Committee: +80 days

##### Stage 2: Bid Stage (Minimum: 6 months)

- Sale of request for proposal (RFP) short-listed applicants: +90 days
- Submission of query by the perspective applicants: +105 days
- Pre-bid meeting: +110 days
- Authority response to queries: +130 days
- Bid submission due date: +150 days
- Opening of bids: +150 days
- Letter of Intent (LOI): within 30 days of bid opening date
- Contract signing: +30 days of award of LOI

#### Notes:

1. The bidding process takes 6 months minimum. However, depending upon the urgency and requirement of the project execution the bidding process could be done within 60 days.
2. +“x” days means time duration from the zero date, i.e., date of publication of RFP.

### 5.4.3 REQUEST FOR PROPOSAL (RFP) FROM ULBs



RFP provides information to the bidders that is useful for preparing their financial offers

The RFP is a document that ULBs prepare to elicit bids from potential vendors. The quality of an RFP is very important for successful project management because it clearly delineates the deliverables that will be required. This RFP includes statements that reflect various assumptions and assessments by the authority in relation to the project. Such assumptions, assessments, and statements do not contain all the information that each bidder may require.

The RFP should be organized into three volumes:

- Volume I: Instruction to bidders
- Volume II: Minimum mandatory technical and performance specifications or project information memorandum
- Volume III: Concession agreement

#### 5.4.3.1 VOLUME I: INSTRUCTION TO BIDDERS (ITB)

The instruction to bidders specifies procedures to be followed by bidders in preparation and submission of their proposals and provides information on submission, opening, evaluation of proposals, and award of concession.

Indicative contents of the instruction to bidders include the following:

- General conditions
  - General responsibilities of bidding
  - Fraud and corrupt practices
- Contents and submission of proposal
  - Cost of proposal
  - Language and currency
  - Number of proposal
  - Eligibility and pre-qualification
  - Bid security
    - Performance guarantee
  - Guidelines for submission of proposal: The bidder shall submit the proposal in accordance with the guidelines prescribed in the RFP and ensure that the proposal is complete in all aspects. The authority reserves the right to reject proposals that do not conform to the guidelines prescribed.
    - The proposal shall be submitted in three parts, viz.,  
Part I: Response to pre-qualification requirements

Part II: Technical offer and

Part III: Financial offer

- Proposal due date and validity period
- Late submission of proposal
- Modifications, substitution or withdrawal of proposal
- Verification of information and site visit
- Right to accept or reject any or all bids
- Eligibility and pre-qualification
  - Technical capacity as per eligibility criteria
  - Financial capability
  - Change in ownership
  - Lock in periods
- Evaluation of bids
  - Confidentiality and non-discriminatory process to be defined
  - Clarifications
  - Evaluation: Part I – Response to pre-qualification requirements
  - Evaluation: Part II – Technical offer
  - Evaluation: Part III – Financial offer
  - Notification and issue of LoI
  - Conditions precedent for issue of letter of award
  - Authority’s right to accept or reject proposal

#### **5.4.3.2 VOLUME II: MINIMUM MANDATORY TECHNICAL AND PERFORMANCE SPECIFICATIONS OR PROJECT INFORMATION MEMORANDUM**

- Brief description of the project
  - Scope of work
- General technical design requirements and standards
- Specific design requirements and standards for each facility
- Operation and performance requirements
- Existing infrastructure

#### **5.4.3.3 VOLUME III: DRAFT CONCESSION AGREEMENT**

The draft concession agreement specifies various details pertaining to the project in its various articles. Formats for information to be provided by the bidder are specified in the various schedules of the concession

agreement. A list of articles to be included in the concession agreement is given in Table 5.5:

**Table 5.5: List of Articles in the Concession Agreement<sup>10</sup>**

| ARTICLES   | DESCRIPTION   |
|--|---|
| <b>ARTICLE I:</b><br>General terms                       | Definitions   |
|  | Interpretations   |
| <b>ARTICLE II:</b><br>Concession                         | Grant of concession   |
|  | Rights associated with the grant of concession              |
|  | Concession period   |
|  | Extension of concession                                     |
|  | Acceptance of concession                                    |
|  | Conditions precedent for waste processing & landfill (WPLF) |
|  | Non-compliance with conditions precedent                    |
| <b>ARTICLE III:</b><br>Project site                      | Applicable permits  |
|  | Lease of land   |
|  | Handover of project site                                    |
|  | Rights, title and use of project site                       |
|  | Peaceful possession   |
| <b>ARTICLE IV:</b><br>Monitoring of the project facility | Composition of committee                                    |
|  | Specific obligations of the committee                       |
|  | Frequency and expenses related to meetings                  |
|  | Role of the committee                                       |
|  | Right to appoint an external consultant                     |
| <b>ARTICLE V:</b><br>Concessionaire's obligations        | Performance bank guarantee                                  |
|  | General obligations   |
|  | Arrangement for finances                                    |
|  | Operation and maintenance                                   |
|  | Insurance   |
|  | Clearances, permits, etc                                    |
|  | Specific obligations  |
|  | Miscellaneous obligations                                   |
|  | No breach of obligations                                    |
| <b>ARTICLE VI:</b><br>Municipal body's obligations       | Specific obligations  |
|  | General obligations   |
| <b>ARTICLE VII:</b><br>Payments to the developer         | Payments terms  |
|  | Payment mechanism   |
| <b>ARTICLE VIII:</b><br>Force majeure                    | Force majeure events  |
|  | Duties of parties during force majeure events               |
|  | Costs during the force majeure events                       |
|  | Termination due to force majeure events                     |

<sup>10</sup> Adapted from Draft National Public Private Partnership Policy (2011). Department of Economic Affairs. Government of India. Available at: <http://toolkit.pppinindia.com/solid-waste-management/module2-pfcaa-ppfa.php?links=pfcaa1b>.





**Table 5.5: List of Articles in the concession agreement [contd.]**

| ARTICLES  | DESCRIPTION  |
|---|--|
| <b>ARTICLE IX:</b><br>Events of Default             | Events of default  |
|   | Termination due to events of default                         |
|   | Rights of municipal body upon termination                    |
|   | Rights of parties  |
| <b>ARTICLE X:</b><br>Transfer of Project Facility   | Ownership of project facility                                |
|   | Contractor's obligations                                     |
|   | Municipal body's obligations                                 |
| <b>ARTICLE XII:</b><br>Dispute Resolution           | Amicable resolution  |
|   | Arbitration proceedings                                      |
|   | Performance during dispute                                   |
| <b>ARTICLE XI:</b><br>Representation and Warranties | Contractor's representations and warranties                  |
|   | Municipal body's representations and warranties              |
|   | Obligation to notify change                                  |
| <b>ARTICLE XIII:</b><br>Miscellaneous               | Sub-contract   |
|   | Labour (interests and rights of labours be laid out clearly) |
|   | Interest and right of set off                                |
|   | Governing law and jurisdiction                               |
|   | Waiver   |
|   | Survival   |
|   | Amendments   |
|   | Notices  |
|   | Severability   |
|   | Language   |
|   | No partnerships  |
|   | Exclusion of implied warranties, etc                         |
|   | Counterparts   |

The various Schedules to be included in the concession agreement shall include:

- Schedule I: Details of project sites
- Schedule II: Construction requirement for waste processing facilities
- Schedule III: Fees (format)
- Schedule IV: Land license agreement (format)
- Schedule V: Authorisation
- Schedule VI: Scope of work of monitoring authority
- Schedule VII: Format for performance bank guarantee
- Schedule VIII: Technical scheme for MSWM facility
- Schedule IX: Approach and methodology for construction of MSWM facility
- Schedule X: Service level condition and penalties
- Schedule XI: Operation & maintenance for MSWM facility

#### 5.4.4 SUGGESTED CONTENTS OF PROPOSALS FROM BIDDERS

The proposal shall include the following contents in the formats prescribed by the municipal authority:

##### Response to pre-qualification requirement

- Bid security (as defined )
- Fees for RFP (as defined)
- Form I: Covering letter for proposal submission
- Form II: Details of bidder or bidding consortium
- Form III: Power of attorney of authorized signatory of bidder
- Form IV: Memorandum of association (in case of proposal submitted by a consortium)
- Form V: Power of attorney of lead member (for consortium proposal)
- Form VI: Format for board resolution of bidder or bidding consortium members
- Form VII: Format for non-criminality
- Form VIII: Format for anti-collusion certificate
- Form IX: Details and proof of technical capacity
- Form X: Details and proof of financial capacity
- Form XI: Litigation history
- Certificates from a practising Chartered Accountant in India certifying net worth as per clause 3 (a) supra, along with the documents (if any) as required under relevant clauses. For the purpose of this tender, the term net worth means the shareholders equity plus reserves and surplus
- Copy of memorandum and articles of association or registration document

##### Technical Offer

- Form XI A: Formats for technical proposal
- Form XI B: Technical plan for project facilities
- Form XII: Details of expert team with curriculum vitae

##### Financial Offer

- Form XIII: Project cost break-up sheet indicating costs of all services or components of the contract
- Form XIV: Detailed break-up of operating costs & revenues



### National Guidance for Contracting Public Private Partnership Projects

- Toolkit for public private partnership (PPP) frameworks in municipal solid waste management (MSWM) developed by the Department of Economic Affairs, Ministry of Finance, and Ministry of Urban Development (MoUD) with the support of the Government of India-ADB PPP initiative.
- Government of India, MoUD. 2012. Toolkit for Solid Waste Management: Jawaharlal Nehru National Urban Renewal Mission.  
<http://jnurm.nic.in/wp-content/uploads/2012/11/SWM-toolkit.pdf>
- Government of India, Ministry of Finance. 2011. PPP Toolkit for Improving PPP Decision-Making Processes.  
<http://toolkit.pppinindia.com/solid-waste-management/module1-intro.php?links=intro1>

## 5.4.5 COST ESCALATION

Cost of service provision may increase as a result of an increase in the general costs or in specific cost components of a contract such as fuel or wages, which form the major cost component of any MSWM contract.

### 5.4.5.1 ANNUAL ESCALATION IN GENERAL COSTS

In order to enable stable service provision even in the face of annually escalating general costs, the concessionaire may be allowed an annual increase in the contract value. The following guidance may be used to calculate the allowed increase.

‘y’% increase in the base rate ‘X’ may be given annually to cover the increase in general costs. The increase may be calculated as per these examples:

After 1 year X plus y% of X

After 2 years X plus 2y% of X

After 3 years X plus 3y% of X

After 10 years X plus 10y% of X

After 14 years X plus 14y% of X

Where X is the “base rate” accepted at the time of award of contract as against rate per tonnes quoted by the selected bidder.



MSWM contracts are sensitive to fluctuations in labour and fuel costs; contracts should build in mechanisms to enhance the cost of the contract when there is an escalation of these prices, otherwise contracts may fail

### 5.4.5.2 PRICE INCREASE ON ACCOUNT OF INCREASE IN DIESEL OR STAFFING COSTS

Besides the general costs, the concessionaire shall be given an increase or decrease in the diesel component as well as minimum wages component as and when the rates are increased or decreased.

For the purpose of calculations (as per formula given below), the cost component of diesel may be taken as 25% of base rate X and the cost component of minimum wages of workers may be taken as 45% of base rate X. The increase in price of diesel or minimum wages will be compensated by giving a proportionate increase in the aforesaid percentage component of diesel and minimum wages.

If the price of diesel or alternate fuel (for the vehicle and equipment used for providing MSWM services) reduces, the tendering authority could on its own motion order review of the diesel or fuel price and



#### Calculating Price Increase on Account of Increase in Diesel and Minimum Wage

$$E(Rs) = A \times B \left\{ \frac{C}{D} - 1 \right\}$$

New Rate payable on account of price increase =  $A \pm E$

#### Diesel

- A = base rate at the time of signing the Concession Agreement
- B = % of diesel component in 'base rate' fixed at the time of signing the Concession Agreement i.e. 25%
- C = Actual rate of diesel at the time of price increase
- D = Rate of diesel at the time of award of Concession or previous revision whichever is later
- E = Increase/decrease in diesel component

|     |       |                                       |
|-----|-------|---------------------------------------|
| A = | 800   |                                       |
| B = | 25%   |                                       |
| C = | 60.00 |                                       |
| D = | 55.00 |                                       |
|     |       | $= 800 \times 0.25 \times (1.09 - 1)$ |
|     |       | $= 800 \times 0.25 \times 0.09$       |
|     |       | $= 800 \times 0.0227$                 |
|     |       | <b>= 18.16</b>                        |

#### Minimum Wage

- A = Base rate at the time of signing of the Concession Agreement
- B = Percentage of Minimum Wage component in 'base rate' fixed at the time of signing of the Concession Agreement i.e. 45 %
- C = Minimum wages as increased now by Govt.
- D = Minimum wages at the time of award of the Concession or previous review
- E = Increase/decrease in Minimum Wage component

|     |        |                                  |
|-----|--------|----------------------------------|
| A = | 800    |                                  |
| B = | 45%    |                                  |
| C = | 180.00 |                                  |
| D = | 160.00 |                                  |
|     |        | $= 800 \times 0.45 \times 0.125$ |
|     |        | $= 800 \times 0.45 \times 0.125$ |
|     |        | <b>= 45</b>                      |

Therefore, further increase in the base rate at the time of review will be Rs. 18.16 as Diesel component + Rs. 45/- as minimum wage component = Rs. 63.16

The Base Rate of 800 /- will now is 863.16 from the date of such increase.

minimum wages and reduce the increase in the base rate already given, subject to the condition that the final base rate X shall not be reduced below the original rate accepted or granted by the tenderer.

#### 5.4.6 EVALUATION AND SELECTION

An evaluation team, appointed by the municipal authority, will scrutinize the tender documents. The team will assess the applications for completeness and eligibility of the tendering bidders as per conditions mentioned in the terms of references (ToR). This process from publication of the expression of interest (EoI) to the selection of the final contractor usually takes about 6 months.

The evaluation committee shall shortlist all eligible bidders. Final selection may be based on specific criteria specified in the (ToR). The following criteria may be considered:

1. Relevant qualification and experience of the bidder
2. Expertise of the bidding team
3. Financial capability of the bidder
4. Approach and methodology suggested
5. Reliability of the bidder (based on previous conduct)
6. Proposed pricing structures and cost to the ULB
7. Environmental and social safeguards provided or ensured
8. Assumption of risk liability and proposed mitigation measures

The ULB may enter into further negotiations with the highest ranked bidder. The contracting and service agreement should be finalized based on the agreements subsequent to the negotiation process.



#### Enabling Conditions for Successful Public Private Partnership Contracts

- A transparent bidding process
- Timely handover of facilities free from encumbrances (physical and legal)
- Expeditious clearances, approvals, and decision-making process (delays have serious consequences)
- A sustainable project structure and revenue model with appropriate risk allocation
- Price sensitivity of the financial proposal, specifically with respect to capital, subsidies, or sale of products (a robust indicator of the financial viability of proposed projects, even when there is a change in the assumed circumstances)
- Political and stakeholder involvement and acceptance (crucial pre requisites)
- Cost recovery or revenue mechanisms based on a real-world assessment
- Transparent subsidies and credit enhancement to expedite financial closure
- Clear performance-based indicators
- Appropriate incentives

## 5.4.7 CONTRACT MONITORING

A contract monitoring cell should be established within the MSWM department to monitor performance or clauses as specified in the contract

Contract models detailed above and in Step 4 of the planning process are only as effective as their implementation. In this context, monitoring plays an important role in ensuring delivery of services which meet required specifications.

Based on specifications of the contract, the ULB should develop checklists, milestones, and inspection schedules. A specific monitoring cell should be established within the MSWM department, with a clear definition of roles and responsibilities. Table 5.5 gives an indication of specific activities that the contractor and the ULB should perform to ensure successful project implementation.

**Table 5.6: Contract Monitoring – Activities or Clauses**

| SL. NO | ACTIVITIES/ CLAUSES   | SPECIFIC ACTIONS   | PRIMARY RESPONSIBILITY | MONITORING AGENCY |
|--------|---|--|------------------------|-------------------|
| 1      | Applicable permits other than land clearances                       | <ul style="list-style-type: none"> <li>List applicable permits under various laws and rules, respective authorities, validity of permits, fees payable, and persons responsible to obtain the permits.</li> <li>Obtain necessary permits.</li> </ul>   | Contractor             | ULB               |
| 2      | Appointment of project in-charge, engineer, or independent engineer | <ul style="list-style-type: none"> <li>Select or identify a suitable person from within the department or appoint a qualified person to be responsible for monitoring project implementation.</li> </ul>   | ULB                    | ULB               |
| 3      | Performance bank guarantee  | <ul style="list-style-type: none"> <li>PBG to be furnished by contractor</li> </ul>  | Contractor             | ULB               |
| 4      | Project design  | <ul style="list-style-type: none"> <li>Project engineer or in-charge shall approve project design drawings, equipment specifications, spares list, electrical drawings, and operating plan.</li> <li>Standard operating procedure(SOP) are to be prepared for all activities.</li> <li>ULB officer-in-charge shall approve and sign all project design documents.</li> </ul> | Contractor             | ULB               |
| 5      | Insurance   | <ul style="list-style-type: none"> <li>Obtain valid insurance and covering risks, and ensure timely renewal of validity.</li> </ul>  | Contractor             | Contractor        |

**Table 5.6: Contract Monitoring – Activities or Clauses [contd.]**

| SL. NO | ACTIVITIES/ CLAUSES      | SPECIFIC ACTIONS  | PRIMARY RESPONSIBILITY | MONITORING AGENCY |
|--------|--------------------------|---|------------------------|-------------------|
| 6      | Environmental compliance | <ul style="list-style-type: none"> <li>Carry out regular environmental, social, health, and safety audits and safety and first aid trainings, and ensure use of personal protective equipment (PPEs).</li> </ul>  | Contractor             | ULB               |
| 7      | General obligations      | <ul style="list-style-type: none"> <li>Valid Public Liability Insurance and renewal;</li> <li>Employee State Insurance (ESI) &amp; Employees' Provident Fund (PF) payments</li> <li>List of persons responsible for these actions to be maintained by the contractor and submitted to the ULB.</li> </ul>   | Contractor             | Contractor        |
| 8.     | Specific obligations     | <ul style="list-style-type: none"> <li>ULB shall declare and enforce a "no development zone;" develop a buffer zone; and ensure that biomedical, industrial hazardous, and construction and demolition (C&amp;D) waste are not brought to the MSW processing facility.</li> <li>Ensure timely notice on events of defaults or force majeure.</li> <li>ULBs are to make timely payments.</li> </ul>  | ULB                    | ULB               |
| 9.     | Maintenance of records   | <ul style="list-style-type: none"> <li>Maintain daily record of human resources, equipment deployed, incoming vehicle details (vehicle number and driver), net weight of incoming and outgoing waste, and timing of entry and exit of vehicles.</li> <li>A ULB representative, who is to be stationed at treatment or processing facility, shall ensure maintenance of separate registers for waste delivered at processing facilities and disposal site, and outgoing processed products and outgoing rejects from the processing plants with triplicate gate pass.</li> </ul> | Contractor             | ULB               |

**Table 5.6: Contract Monitoring – Activities or Clauses [contd.]**

| SL. NO | ACTIVITIES/ CLAUSES      | SPECIFIC ACTIONS  | PRIMARY RESPONSIBILITY | MONITORING AGENCY |
|--------|--------------------------|---|------------------------|-------------------|
| 10     | Operations & maintenance | <ul style="list-style-type: none"> <li>• There must be approved standard operating procedures (SOP), recommended spares list and minimum inventory, and regular audit of these stocks.</li> <li>• Ensure maintenance of equipment.</li> </ul> | Contractor             | ULB               |
| 11     | Service levels           | <ul style="list-style-type: none"> <li>• Verify and certify achieved service levels.</li> <li>• Identify defaults.</li> <li>• Assess compliance.</li> <li>• Issue notices and follow up on previous notices or assurances.</li> </ul>         | ULB                    | ULB               |

Identifying and mobilising financial sources is central to the MSWM plan implementation

## 5.5 OPERATIONALISING THE FINANCIAL PLAN

About 10%–50% of the municipal budget of all ULBs is spent on MSWM, depending on the ULB’s functions and income sources. A financial operating plan gives details of estimated costs and expected revenue sources for all activities indicated in the MSWM plan. Full cost accounting (FCA) principles outlined in Section 1.4.5.6.1 of Part II shall be applied while costing individual actions. Section 1.4.5.6.3 of Part II describes various sources of funding that ULBs could avail.

The ULB should mobilize financial resources identified in the financial operating plan to ensure timely implementation of the plan and service delivery. Public private partnerships (PPPs) and private sector participation (PSP) should be carefully monitored to ensure timely execution of contracted services and avoid cost overruns. ULBs should take necessary precautions to ensure disbursement of funds in time for implementation.



Double entry accrual based accounting shall be followed by the ULB for recording revenues and expenses, in accordance with norms established in the National Municipal Accounting Manual. Municipal solid waste management is assigned a specific function code (41) under the function-group: Sanitation & Municipal Solid Waste Management (40). As per the manual, while recording revenues and expenditure, major revenue and expense heads from the Chart of Accounts shall be indicated along with the function code or budgeting centre code.



## **5.6 ACTION POINTS FOR AWARENESS GENERATION THROUGH INFORMATION, EDUCATION, AND COMMUNICATION ACTIVITIES FOR MUNICIPAL SOLID WASTE MANAGEMENT PLAN IMPLEMENTATION**

- Community should be involved through consultations for deciding the final contours of the MSWM plan.
- Community should be made aware of the socio-economic and environmental safeguards of proposed MSWM initiatives through regular mass communication and information, education, and communication (IEC) campaigns.
- Community should be made aware of their responsibilities for ensuring success of proposed incentives. The impacts of their actions on the success of MSWM plants should be made evident through IEC campaigns.



**Management Aspects:**  
Monitoring Municipal  
Solid Waste  
Management Service  
Provision

## IN THIS SECTION

|     |  |     |
|-----|--|-----|
| 6.1 | Monitoring Municipal Solid Waste Management Service Provision  | 467 |
| 6.2 | Operation and Maintenance Plan for Municipal Solid Waste Management Services   | 481 |
| 6.3 | Preventive Maintenance   | 483 |
| 6.4 | Complaint Redressal System   | 485 |
| 6.5 | Environmental and Occupational Health Monitoring of Municipal Solid Waste Treatment, Processing and Disposal Facilities                                    | 487 |
| 6.6 | Training Requirements for Monitoring Municipal Solid Waste Service Provision   | 490 |
| 6.7 | Action Points for Awareness Generation Through Information, Education, and Communication Activities for Monitoring Municipal Solid Waste Service Provision | 491 |

## **6. MANAGEMENT ASPECTS: MONITORING MUNICIPAL SOLID WASTE MANAGEMENT SERVICE PROVISION**

### **6.1 MONITORING MUNICIPAL SOLID WASTE MANAGEMENT SERVICE PROVISION**

Institutionalising appropriate quality assurance systems is essential to ensure a continuous and efficient municipal solid waste management (MSWM) system. The performance of all components of MSWM system, from collection to processing and disposal, should be ensured on a daily basis. This might appear to be very cumbersome, but with a proper system in place, things move routinely and there is assurance of quality. Provision of citizen-centric services should also be monitored through a routine feedback mechanism. This should primarily focus on concerns of the community regarding doorstep collection, primary storage, and transportation of waste.

A comprehensive monitoring and evaluation (M&E) system should be adopted for proper implementation of the MSWM plan and for assessing progress toward meeting the targets of the plan.

The monitoring system adopted should facilitate or include the following:

- regular collection of data by the identified staff, e.g., ward-wise collection of waste;
- analysis of collected information to assess the efficacy of the overall system, e.g., reasons for not reaching 100% collection in an area;
- reporting of data and its analysis to senior officials; and
- mechanisms for proposing corrective action as needed, e.g., contingency plan for extra efforts wherein lagging, rerouting or changing the timings for collection in a particular ward so that 100% collection can be achieved.

The head of the MSWM department should be responsible for M&E. A dedicated M&E team should be constituted from amongst the MSWM department staff, with distinct roles and responsibilities. Field level staff from wards should be inducted from time to time, and reporting schedules should be fixed. Field staff can be reverted to operations once efficiency is achieved.

Ward level committees, constituted as per the directives of the 74<sup>th</sup> Constitution Amendment Act, should also be actively involved in ensuring and monitoring MSWM service provision including segregation, collection, transportation, street sweeping, drain cleaning, and prohibition of littering. Such a process should be institutionalised

through a council resolution, as is being practiced in Bengaluru. Community involvement in monitoring service provision has also been found effective in some states. Andhra Pradesh had implemented a “Know Your Sanitary Worker” programme, under which all residents of an area were introduced to the concerned sanitary workers in that area. Contact details of these workers and their supervisors were also made available to facilitate reporting of service delivery issues and to reduce the response time in redressal of complaints.

### 6.1.1 DATA COLLECTION AND ANALYSIS FOR MONITORING

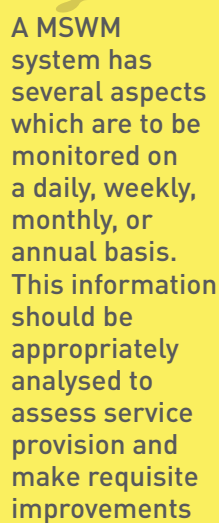

A MSWM system has several aspects which are to be monitored on a daily, weekly, monthly, or annual basis. This information should be appropriately analysed to assess service provision and make requisite improvements

The first step towards implementing a monitoring and evaluation (M&E) system is to acquire the requisite data for assessing the performance of the MSWM system. Reports generated should contain critical information and should be effectively used for decision making, identifying gaps and corrective measures. Standard formats should be developed for producing reports on daily, monthly, quarterly, or annual basis as per the requirement. This information can be collected and analysed at the city level, zone level, or ward level depending on the monitoring requirements.

The best way to achieve this is through a computerised management information system (MIS). The information collected and reported through MIS should also be used as a basis for midterm review of the MSWM plan and for defining goals of future planning.

There is considerable overlap between data required for monitoring MSWM service provision and data required to establish a baseline for MSWM service provision. Table 6.1 highlights the key information that must be periodically collected and analysed by urban local bodies (ULBs) to operate and monitor MSWM systems as prescribed in SWM Rules, 2016.

The table also includes a visual indication for Service Level Benchmarks (SLB) for identifying data elements which are used directly in the computation of service level benchmarks (SLBs) for MSWM service provision. SLB indicators are stipulated by the Ministry of Urban Development (MoUD) to assess the level of service provision and resource efficiency.

**Table 6.1: Municipal Solid Waste Management Data Collection and Analysis<sup>1</sup>**

| DATA REQUIRED  | MINIMUM FREQUENCY OF MEASUREMENT                         | POINT OF DATA COLLECTION   | DATA USE AND POTENTIAL ANALYSIS  |
|--|--|--|--|
| <b>GENERAL ULB INFORMATION <b>SLB</b></b>  |  |  |  |
| <ul style="list-style-type: none"> <li>Area of the ULB</li> <li>Number of wards, their area and population</li> <li>Population of the ULB</li> <li>Decadal growth of population</li> <li>Number of households</li> <li>Average size of households</li> <li>Number of slum households</li> <li>Number of commercial establishments</li> <li>Number of markets (vegetable, meat, wholesale, flower, etc.) and slaughterhouses</li> <li>Number of institutions (offices, schools, colleges, etc.)</li> <li>Number of health care establishments</li> <li>Number of industries including cottage industries</li> </ul> | At least once in 3 years                                 | ULB (from weighbridge)   | Baseline information to be used for further analysis and as a basis for calculating SLB indicators   |
| <b>DOOR TO DOOR COLLECTION</b>   |  |  |  |
| <ul style="list-style-type: none"> <li>Total amount of waste generated in the ULB <b>SLB</b></li> <li>Quantity of waste collected from different sources at doorstep: <ul style="list-style-type: none"> <li>Household, shops, and establishments <b>SLB</b></li> <li>Vegetable and food market</li> <li>Meat, fish and slaughter houses</li> <li>Construction and demolition waste <b>SLB</b></li> <li>Hospitals</li> <li>Industries</li> </ul> </li> <li>Quantity of waste collected in segregated fractions <b>SLB</b></li> <li>Average number of carcasses removed each day</li> </ul>                         | Monthly<br><br>Semi-annually<br><br>Monthly<br><br>Daily | Ward level (from weighbridge)<br>Ward level (from weighbridge)<br><br>Ward level (from weighbridge)<br>Processing or disposal facility | Assess household collection efficiency<br><br>Assess household collection efficiency<br>Assess requirement or capacity of waste management facilities needed by the ULB<br><br>Extent of segregation of waste<br>Assess requirement for management of carcasses along with slaughterhouse wastes |

<sup>1</sup> Developed by the expert committee for revision of MSWM manual (2013-15)

Table 6.1: Municipal Solid Waste Management Data Collection and Analysis [contd.]

| DATA REQUIRED  | MINIMUM FREQUENCY OF MEASUREMENT | POINT OF DATA COLLECTION | DATA USE AND POTENTIAL ANALYSIS  |
|--|----------------------------------|--------------------------|--|
| <ul style="list-style-type: none"> <li>Total number of vehicles, tricycles and human resources allotted for door to door collection of waste <b>SLB</b></li> </ul> | Daily                            | Ward                     | Assess sufficiency of infrastructure for primary collection of waste                   |
| <ul style="list-style-type: none"> <li>Capacity of vehicles dedicated to primary, secondary and tertiary collection <b>SLB</b></li> </ul>                          | Monthly                          | Ward                     | Assess sufficiency of infrastructure for primary collection of waste                   |
| <ul style="list-style-type: none"> <li>Number of trips made per day per vehicle type <b>SLB</b></li> </ul>   | Monthly                          | Ward                     | Assess sufficiency of infrastructure for primary collection of waste                   |
| <ul style="list-style-type: none"> <li>Number of vehicles, tricycles and human resources actually reporting for duty</li> </ul>                                    | Daily                            | Ward                     | Assess utilisation rates of existing infrastructure                                    |
| <ul style="list-style-type: none"> <li>Short fall in human resources</li> </ul>  | Daily                            | Ward                     | Assess sufficiency of existing staffing  |
| <ul style="list-style-type: none"> <li>Areas left unattended</li> </ul>  | Daily                            | Ward                     | Assess efficiency of door-to-door service provision and identify problem areas         |
| <ul style="list-style-type: none"> <li>Arrangements made or proposed to be made for clearing the backlog of pending work</li> </ul>                                | Daily                            | Ward                     | Ensuring daily management of service provision   |
| <ul style="list-style-type: none"> <li>Number of sites designated for secondary waste storage</li> </ul>   | Monthly                          | Ward                     | Data to be used to assess sufficiency of secondary collection points or storage depots |
| <ul style="list-style-type: none"> <li>Type and size of containers / storage depots in each ward</li> </ul>  | Monthly                          | Ward                     |  |
| <ul style="list-style-type: none"> <li>Quantity of waste deposited at storage depots on a daily basis <b>SLB</b></li> </ul>  | Monthly                          | Ward                     |  |
| <ul style="list-style-type: none"> <li>Number of unauthorised waste dumping points in each ward</li> </ul>   | Monthly                          | Ward                     |  |
| <b>STREET SWEEPING</b>   |                                  |                          |  |
| <ul style="list-style-type: none"> <li>Number of sanitation workers on duty for street sweeping (contractual vs pay-roll)</li> </ul>                               | Daily                            | Ward                     | Ensuring efficiency and daily management of street sweeping service provision          |
| <ul style="list-style-type: none"> <li>Number of sanitary workers absent</li> </ul>  | Daily                            | Ward                     |  |
| <ul style="list-style-type: none"> <li>Arrangements made or proposed for clearing the backlog of street sweeping</li> </ul>  | Daily                            | Ward                     |  |
| <b>SILT REMOVAL OR DRAINAGE CLEANING</b>   |                                  |                          |  |
| <ul style="list-style-type: none"> <li>Number of sanitation workers on roll for silt removal in the ward</li> </ul>  | Daily                            | Ward                     | Ensuring efficiency and daily management of street sweeping service provision          |
| <ul style="list-style-type: none"> <li>Number of persons found absent or on leave</li> </ul>   | Daily                            | Ward                     |  |
| <ul style="list-style-type: none"> <li>Arrangements made or proposed for clearing the backlog of silt removal</li> </ul>   | Daily                            | Ward                     |  |



Table 6.1: Municipal Solid Waste Management Data Collection and Analysis [contd.]

| DATA REQUIRED   | MINIMUM FREQUENCY OF MEASUREMENT | POINT OF DATA COLLECTION | DATA USE AND POTENTIAL ANALYSIS   |  |
|---|----------------------------------|--------------------------|---|--|
| <b>CONSTRUCTION AND DEMOLITION WASTE (C&amp;D WASTE)</b>  |                                  |                          |   |  |
| • Number of designated C&D sites identified in the city with capacity and location                        | Monthly                          | Ward                     | Assess the demand for C&D waste management in the ULB and identify illegal or non-notified dump sites to prevent such dumping   |  |
| • Number of unauthorised disposal sites for C&D waste in the city (permanent or semi-permanent)           | Monthly                          | Ward                     |   |  |
| • Quantity of C&D waste lying unattended (based on truckloads) at designated sites and unauthorised sites | Weekly                           | Ward                     |   |  |
| <b>TRANSPORTATION OF WASTE</b>  |                                  |                          |   |  |
| • Number and type of vehicles and equipment allotted <b>SLB</b>   | Daily                            | Ward /ULB                | Assess the sufficiency and efficacy of:<br>1. Secondary waste collection and transportation<br>2. Amount of waste collected and transported versus waste generated<br>3. Efficiency of the vehicle maintenance system |  |
| • Number and type of vehicles and equipment that actually reported for duty                               | Daily                            | Ward /ULB                |   |  |
| • Number of trips made to the processing site or disposal site by each vehicle in one shift <b>SLB</b>    | Daily                            | Ward /ULB                |   |  |
| • Number of vehicles used in first, second, and third shift   | Daily                            | Ward /ULB                |   |  |
| • Total quantity of waste transported from weighbridge records <b>SLB</b>                                 | Daily                            | Ward /ULB                |   |  |
| • Number of vehicles that did not make adequate trips   | Daily                            | Ward /ULB                |   |  |
| • Number of vehicles that transport waste but were not totally full                                       | Daily                            | Ward /ULB                |   |  |
| • Number of bins cleared during the day   | Daily                            | Ward /ULB                |   |  |
| • Number and location of bins left uncleared  | Daily                            | Ward /ULB                |   |  |
| • Breakdown reported during the day and action taken  | Daily                            | Ward /ULB                |   |  |
| • Arrangements made or proposed for clearing the backlog  | Daily                            | Ward /ULB                |   |  |
| <b>WORKSHOP FOR VEHICLES AND EQUIPMENT</b>  |                                  |                          |   |  |
| • Total number of vehicles or equipment on the road   | Weekly                           | ULB                      |   | 1. Assess the road worthiness of vehicles based on number of breakdowns<br>2. Assess operational issues with equipment<br>3. Sufficiency of workshop facilities<br>4. Efficiency and time taken to repair vehicles or equipment as compared to proposed tentative time |
| • Number of vehicles or type of equipment under repair  | Weekly                           | ULB                      |   |  |
| • Nature and duration of breakdown  | Weekly                           | ULB                      |   |  |
| • Time taken to repair vehicle or equipment   | Weekly                           | ULB                      |   |  |
| • Alternate arrangements made for vehicle or equipment  | Weekly                           | ULB                      |   |  |

**Table 6.1: Municipal Solid Waste Management Data Collection and Analysis [contd.]**

| <b>DATA REQUIRED</b>   | <b>MINIMUM FREQUENCY OF MEASUREMENT</b> | <b>POINT OF DATA COLLECTION</b> | <b>DATA USE AND POTENTIAL ANALYSIS</b>   |   |
|--|---|---------------------------------|--|---|
| <b>PROCESSING SITE</b>   |   |                                 |  |   |
| • Number of waste processing sites in the ULB                                | Annually                                | ULB                             | Assess the sufficiency of existing facilities to process/dispose collected waste   |   |
| • Distance of the processing plants from the ULB                             | Annually                                | ULB                             |  |   |
| • Area/Capacity of the sites / facilities <b>SLB</b>                         | Annually                                | ULB                             |  |   |
| • Total operating hours of the processing plant                              | Weekly                                  | Plant                           | <ol style="list-style-type: none"> <li>1. Assess capacity and efficiency of processing plant</li> <li>2. Assess process efficiency</li> <li>3. Assess quality of the products</li> <li>4. Identify potentially hazardous situations w.r.t. type of incoming waste or waste handling/ process mechanisms</li> </ol> |   |
| • Quantity of waste received at the plant <b>SLB</b>                         | Daily                                   | Plant                           |  |   |
| • Quantity of end products (compost, RDF) produced at the plant <b>SLB</b>   | Monthly and per batch                   | Plant                           |  |   |
| • Quality of end products (compost, RDF) produced at the plant               | Monthly and per batch                   | Plant                           |  |   |
| • Quantity of end products sold <b>SLB</b>                                   | Monthly                                 | Plant                           |  |   |
| • Quantity of end product in stock   | Monthly                                 | Plant                           |  |   |
| • Quantity of reject material <b>SLB</b>                                     | Monthly                                 | Plant                           |  |   |
| • Number of staff employed (Sex disaggregated data and the of work allotted) | Monthly                                 | Plant                           |  |   |
| • Any irregularities noticed   | Monthly                                 | Plant                           |  |   |
| <b>WASTE DISPOSAL SITE</b>   |   |                                 |  |   |
| • Number of waste disposal sites in the ULB                                  | Annually                                | ULB                             |  | <ol style="list-style-type: none"> <li>1. Assess sufficiency of existing waste disposal sites</li> <li>2. Assess quantity of waste disposed vis a vis amount of rejects from processing facilities/ inerts to be disposed</li> <li>3. Identify remaining life of the landfill</li> <li>4. Extent of scientific disposal of municipal solid waste</li> </ol> |
| - Number of dumpsites  |   |                                 |  |   |
| - Number of sanitary landfills   | Annually                                | ULB                             |  |   |
| • Distance of the disposal or landfill site from the ULB                     | Annually                                | ULB                             |  |   |
| • Area of the disposal or landfill site                                      | Daily                                   | ULB                             |  |   |
| • Quantity of waste disposed each day <b>SLB</b>                             | Annually                                | ULB                             |  |   |
| • Expected life of each landfill site  | Annually                                | ULB                             |  |   |

Table 6.1: Municipal Solid Waste Management Data Collection and Analysis [contd.]

| DATA REQUIRED   | MINIMUM FREQUENCY OF MEASUREMENT | POINT OF DATA COLLECTION | DATA USE AND POTENTIAL ANALYSIS   |
|---|----------------------------------|--------------------------|---|
| <b>FINANCIAL ASPECTS</b>  |                                  |                          |   |
| • Operating Cost  | Annually                         | ULB                      | 1. Assess cost of MSWM services in the ULB<br>2. Assess collection efficiency of waste management charges<br>3. Assess which of the MSWM services are financially viable<br>4. Extent of cost recovery for the ULB in the MSWM services |
| • Cost of collection per tonnes per day <b>SLB</b>  | Quarterly (once in three months) | ULB                      |   |
| • Cost of transport per tonnes per day <b>SLB</b>   | Quarterly (once in three months) | ULB                      |   |
| • Cost of disposal per tonnes per day <b>SLB</b>  | Quarterly (once in three months) | ULB                      |   |
| • Human resource costs <b>SLB</b>   | Quarterly (once in three months) | ULB                      | 1. Assess that the budget addresses all priority services<br>2. Extent of cost recovery for the ULB in the MSWM services  |
| • Cost of operations and maintenance for services managed by the ULB (recurrent fuel, electricity and maintenance costs) <b>SLB</b> | Quarterly (once in three months) | ULB                      |   |
| • Cost recovery for MSWM service through tax, user fees, etc. <b>SLB</b>  | Quarterly (once in three months) | ULB                      |   |
| • Allocation of revenue and capital budget  | Quarterly (once in three months) | ULB                      |   |
| <b>COMPLAINTS REDRESSAL</b>   |                                  |                          |   |
| • Number of MSWM related complaints received <b>SLB</b>   | Daily                            | ULB                      | 1. Assess and identify repeated problem areas<br>2. Assess efficiency of complaint redressal  |
| • Types of complaints received  | Daily                            | ULB                      |   |
| • Time taken for issues to be resolved and appropriate actions taken <b>SLB</b>   | Daily                            | ULB                      | Assess efficiency of penalising defaulters, as a deterrent to future non-compliance   |
| • Number of defaults for which penalties are collected  | Quarterly (once in three months) | ULB                      |   |
| <b>LEGAL MATTERS</b>  |                                  |                          |   |
| • Number of cases filed in the courts each month for violation of provision of rules and applicable laws                            | Monthly                          | ULB                      | Assess and ensure legal compliance  |
| • Corrective measures taken   | Monthly                          | ULB                      |   |

## 6.1.2 MONITORING ACHIEVEMENT OF SERVICE LEVEL BENCHMARKS

Eight SLB indicators are defined by the MoUD to assess MSWM service provision in a ULB

Assessment of service level benchmarks (SLBs) is based on the analysis of information collected to monitor the municipal solid waste management (MSWM) system on a regular basis, as discussed in the previous section. State governments use SLBs to monitor long-term progress of MSWM service provision in ULBs. Release of funds from the Finance Commission is partially contingent on achievement of predefined goals of SLBs. Indicators stipulated by the Ministry of Urban Development (MoUD) for benchmarking MSWM service provision are the following:

1. Household level coverage of solid waste management services
2. Efficiency of collection of municipal solid waste efficiency
3. Extent of segregation of municipal solid waste
4. Extent of municipal solid waste recovered
5. Extent of scientific disposal of municipal solid waste
6. Efficiency in redressal of customer complaints
7. Extent of cost recovery in SWM services
8. Efficiency in collection of SWM charges

A framework for monitoring and reporting on these indicators is given in Table 6.2. Detailed guidance on data requirements and calculation methods may be found in MoUD's "Handbook of Service Level Benchmarking".

**Table 6.2: Monitoring Achievement of Service Level Benchmarks for Municipal Solid Waste Management Service Provision<sup>2</sup>**

| PERFORMANCE INDICATORS                            | UNIT | DEFINITION  | MINIMUM FREQUENCY OF PERFORMANCE MEASUREMENT AND REPORTING                      | SMALLEST GEOGRAPHICAL AREA FOR MEASUREMENT |
|---|------|---|---|--|
| Household level coverage of SWM services          | 100% | Doorstep collection in percentage from households and other establishments  | The monitoring of performance – monthly<br>Reporting and Evaluation – quarterly | Ward level                                 |
| Efficiency of collection of municipal solid waste | 100% | Collection efficiency is defined as percentage of waste collected by the municipal authority or authorised private waste collector excluding waste recycled by the households or informal waste pickers | The monitoring of performance – daily<br>Reporting and Evaluation – monthly     | Ward level                                 |

<sup>2</sup> "Handbook of Service Level Benchmarking", MoUD, 2008.

**Table 6.2: Monitoring achievement of Service Level Benchmarks for Solid Waste Management Service Provision [contd.]**

| PERFORMANCE INDICATORS                                 | UNIT | DEFINITION   | MINIMUM FREQUENCY OF PERFORMANCE MEASUREMENT AND REPORTING                   | SMALLEST GEOGRAPHICAL AREA FOR MEASUREMENT |
|--|------|--|--|--|
| Extent of segregation of municipal solid waste         | 100% | Percentage of households and other establishments that segregate their garbage into wet and dry waste at the source.   | Monitoring of performance – daily<br>Reporting and Evaluation – monthly      | Ward level                                 |
| Extent of municipal solid waste recovery               | 80%  | Percentage of municipal waste recovered or processed by the ULBs, households and informal sector   | Monitoring of performance – daily<br>Reporting and Evaluation: monthly       | Ward level                                 |
| Extent of scientific disposal of municipal solid waste | 100% | Percentage of waste disposed at the landfill, which is designed, operated and maintained as per set standards  | Monitoring of performance – daily<br>Reporting and Evaluation – monthly      | ULB level                                  |
| Efficiency in redressal of customer complaints         | 80%  | Percentage of complaints related to municipal waste management redressed within a given time period  | Monitoring of performance – daily<br>Reporting and Evaluation – monthly      | Zone or ULB level                          |
| Extent of cost recovery in SWM services                | 100% | This indicator denotes the extent to which the ULB is able to recover all operating expenses relating to SWM services from operating revenues of sources related exclusively to SWM. | Monitoring of performance – quarterly<br>Reporting and Evaluation – annually | ULB level                                  |
| Efficiency in collection of SWM charges                | 90%  | It is defined as current year revenues collected, expressed as a percentage of the total operating revenues, for the corresponding time period.                                      | Monitoring of performance – quarterly<br>Reporting and Evaluation – annually | ULB level                                  |

### 6.1.3 MANAGEMENT INFORMATION SYSTEM

Collection and analysis of data related to MSWM is required to assess the existing situation and propose adequate measures for improving service delivery. Management information system (MIS) is a computerised system which can help capture, store, and retrieve data or information for decision makers. MIS can manage large amounts of data such as waste collection points, location of bins, designated secondary storage

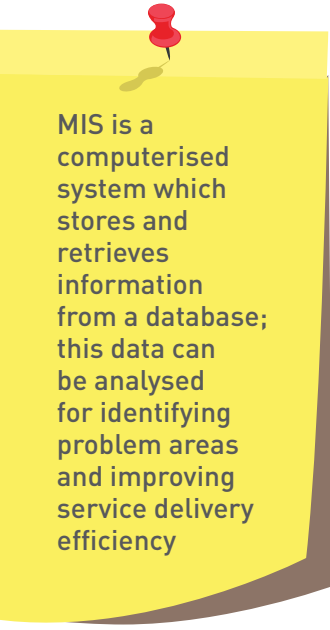

MIS is a computerised system which stores and retrieves information from a database; this data can be analysed for identifying problem areas and improving service delivery efficiency

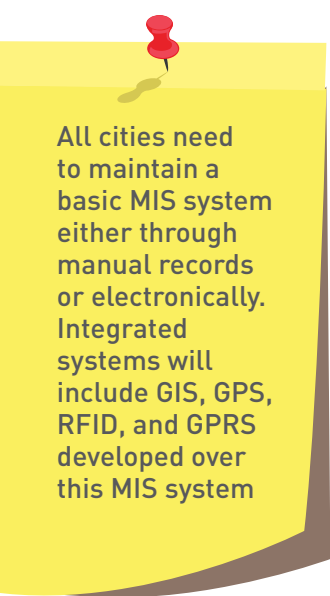

All cities need to maintain a basic MIS system either through manual records or electronically. Integrated systems will include GIS, GPS, RFID, and GPRS developed over this MIS system

points, ward level vehicle movement, information on transportation of waste and its weightment, and other related information as specified in Table 6.1. MIS helps in establishing a strong and reliable information database necessary to facilitate planning, midcourse corrections, and decision making. It enhances transparency and accountability of officials in the MSWM system. Information is the foundation of an MIS system. Therefore, for any ULB to have a sound MIS on solid waste management, it should have a good compilation of basic information ranging from a ward to a city level. Details on the minimum data requirement to establish a MIS is elaborated in Figure 6.1. Essentially all the information that was earlier kept and updated manually in the ULB has to be now available electronically. Creation and maintenance of such information and database is not very resource intensive and requires basic technical expertise at the ULB level.

All cities need to maintain a basic MIS system either through manual records or electronically. Once this system has been established, level two is to connect this basic database on solid waste to be analysed through map based tools and applications. The use of integrated technologies over the basic MIS system such as geographic information systems (GIS), global positioning system (GPS), radio frequency identification (RFID), and general packet radio services (GPRS) have resulted in the development of integrated and comprehensive solutions for MSWM. GIS and remote sensing imageries (visual capture of information using cameras) are now being integrated with MIS to provide spatial and visual validation for provision of services. A GIS system is actually a visual representation of information (attributes) on maps which are geo-referenced (show location coordinates). Data collected for monitoring and evaluation (M&E) of MSWM systems can thus be linked to the geographical locations on a map created in the GIS system. Data on maps can be used to analyse the spatial information and identify patterns, trends, and relationships in the existing information. GIS systems are useful in planning for door-to-door collection, waste transportation routes, location for waste collection bins, etc.

Once the GIS has been linked to the MIS, the system can be further advanced to show real-time spatial information captured through a global positioning system (GPS), e.g., real-time data regarding vehicle movement, secondary collection bin pickup, and transportation to processing and disposal sites can also be linked to the GIS system. Waste transport vehicles may be fitted with a GPS linked to the GIS system to enable real-time monitoring of vehicle movement.

In several advanced MIS systems, radio frequency identification (RFID) tags are used to identify equipment. These are electronic tags which can carry preloaded information specific to the equipment they are tagged to, e.g., secondary collection bins. Electronic scanners equipped with

the general packet radio services (GPRS) technology can scan these tags and relay information to the GIS system, whereby all necessary information fed into the GPRS unit with regard to the equipment is updated automatically. GIS is then used to check the location.

Thus linked with GPRS or RFID systems, GIS provides real-time data on vehicles, collection of waste, bin pickup, and transportation of waste to treatment or disposal facilities.

These systems are now being suitably adopted by cities to improve service efficiency of MSWM. Minimum data requirements for an effective MIS–GIS–GPS system are shown in Figure 6.1.

Advanced communication tools enable reliable and efficient MSWM services:

- GIS
- GPS
- GPRS
- RFID

**Figure 6.1: Minimum Data Requirement for MIS, GIS and GPS Systems**

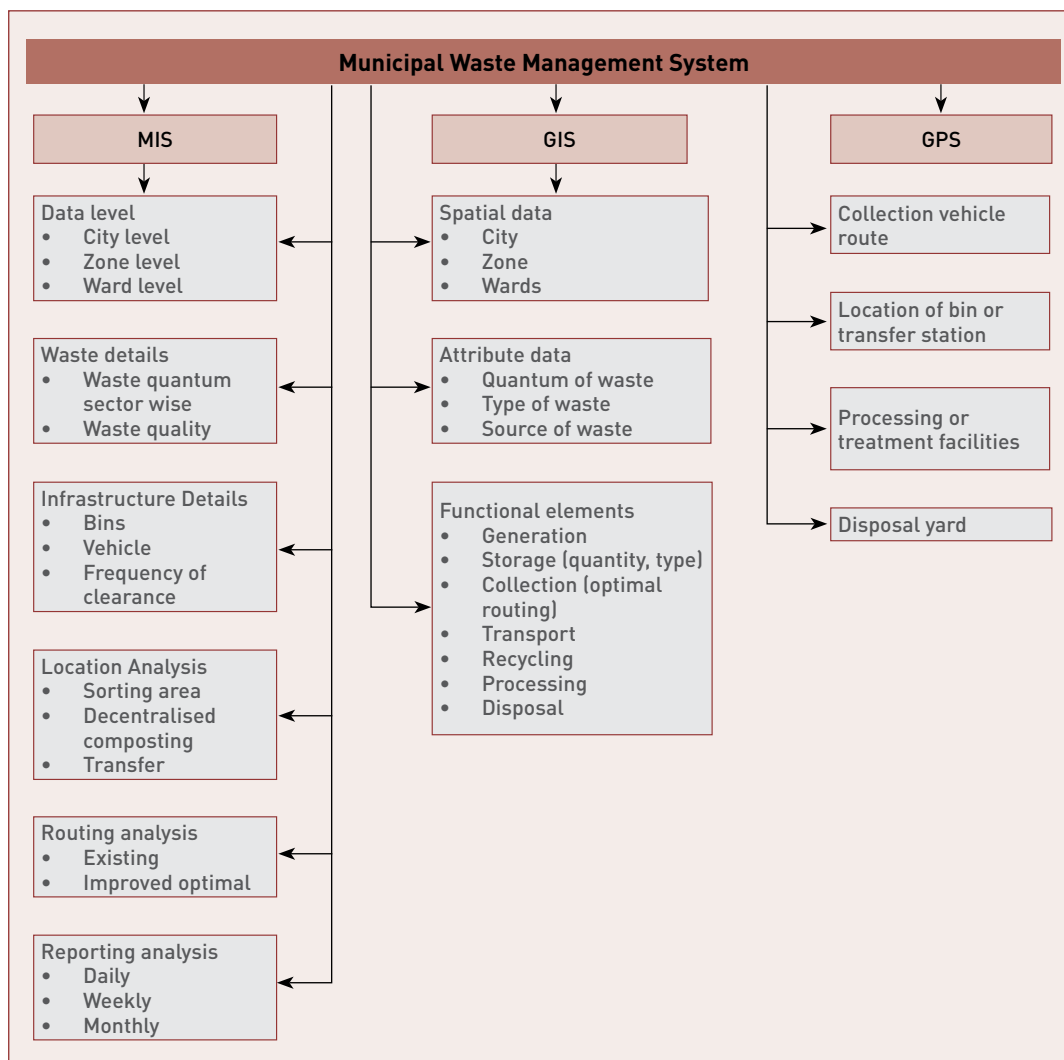

Benefits of these systems include the following:

- Data aggregation and process monitoring are managed electronically, avoiding daily human intervention, thereby increasing reliabil-

ity and transparency of information and helping in resolution of disputes among citizens, contractors, and officials.

- Effective and timely complaint redressal of grievances is generated through online monitoring system.
- Movement of vehicles and tracking of average stoppage time may be monitored in real time by using a surveillance system based on GIS and GPS technologies, thereby reducing noncompliance and enhancing efficiency.
- Status of evacuation of bins on a daily basis can be monitored through RFID and GPRS, facilitating increase in service efficiency and decrease in customer complaints.



### Integrated Technologies (MIS, GIS, GPS, RFID or GPRS) for Monitoring Municipal Solid Waste Management

Real-time monitoring of status of bin clearance, estimation of amount of waste in and around bins, surveillance of movement of vehicles, optimisation of routes, and reallocation of bins according to the estimated waste are possible through integration of several technologies, leading to transparency in civic administration.

As shown in the figure, each container is equipped with a radio frequency identification (RFID) or general packet radio services (GPRS) label having a unique identification code. Low frequency passive tags are proposed because they offer long-term low-cost solutions and are operational in extreme conditions and resistant to environmental hazards. Geo-coding of containers is done manually through field visits and by noting the locations using a global positioning system (GPS) receiver, which in turn is connected to the corporation database or management information system (MIS). When the container gets loaded onto the truck, the reader reads the serial number of the tag on the container. At the same time, the GPS receiver on the truck calculates its location using satellite data. The serial number of the tag, location, date, and time are transmitted in real time via the Global System for Mobile (GSM) network to the communication gateway of the control server. The same is repeated when the truck reaches its destination. After data processing, information is transferred to the geographic information system (GIS) terminal. Real-time information can be shared with clients via a web-based solution.

#### Municipal Solid Waste Monitoring and Management System<sup>3</sup>

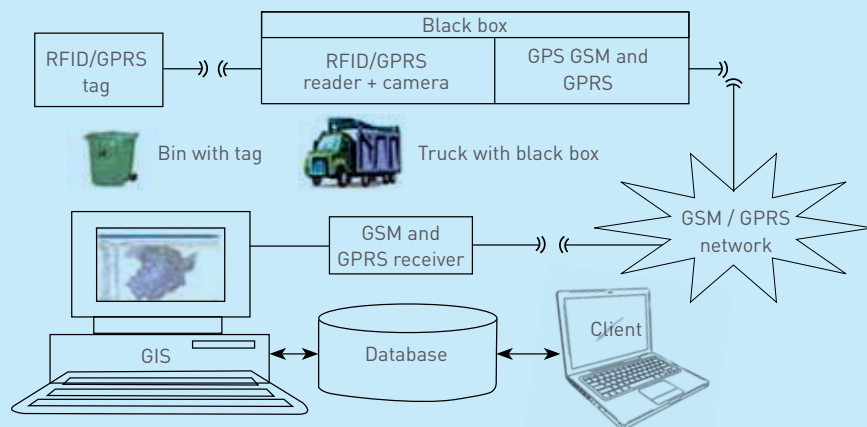

3 'Solid Waste Truck Monitoring and Management using RFID, GIS AND GSM,' Hannan, M. A. et al. (2011). *Journal of Applied Sciences Research*, 7(12).





Even though advanced application systems like GPS, GIS, RFID can add tremendous value to the MIS and the overall MSWM but the value and the need for a strong baseline data cannot be underestimated. In addition, the cost implications of procuring, managing, and maintaining such systems should be understood by the ULB before deciding to adopt them. In order to maintain an efficient MSWM system, these technologies may be considered suitable aids but not a necessity due to their costs and specialised manpower requirements. Regular well-maintained records and coordination among field staff and supervisors will also produce the same level of efficiency in smaller ULBs, where the procurement of such systems may not be cost-effective.



### **Pimpri-Chinchwad Municipal Corporation Monitoring Municipal Solid Waste Management Services through Information and Communication Technologies**

Pimpri-Chinchwad Municipal Corporation (PCMC) has initiated the task of monitoring its municipal solid waste management (MSWM) services through the use of information and communication technologies (ICT). By deploying Global Positioning System (GPS) based real time vehicle tracking system, PCMC is able to:

- monitor the actual movement and realtime position of the vehicle;
- monitor the movement of collection vehicles;
- improve the service delivery mechanism and achieve better information management;
- ensure citizens' participation in governance mechanism for overall improvements in collection efficiency;
- reduce unwanted trips, detours, or stoppages, thereby enhancing the productivity or utilisation of the fleet;
- generate management information system (MIS) report daily to take informed decision; and
- publish the "Bin Pickup Status" on their website to inform citizens and encourage them to monitor bin pickup status in their localities.

This endeavor resulted in improving PCMC's accountability and also offered a reliable tool to facilitate data provision under the Right to Information Act, 2005 where such information is sought.

*Source: Pimpri-Chinchwad Municipal Corporation*



## Effective Monitoring of Collection and Transportation of Municipal Waste through Global Positioning System

**Year of Start:** 2011

**Main Players:** Nashik Municipal Corporation (NMC) – Health Department and Computer Department

**Approach:** Door to door collection of waste in the city was established through *ghantagadis* (designated waste collection vehicles) in 1998. With the start of the Jawaharlal Nehru National Urban Renewal Mission (JnNURM) project, NMC received central funds for strengthening the existing system resulting in the procurement of 124 *ghantagadis* and GPS systems under the project. GPS machines were fitted on each vehicle to improve the collection and transportation efficiency of the vehicles. An agency was appointed by NMC for installation of the GPS system (machines and software) and its operation and maintenance (O&M). A cell (centralised monitoring unit) was formed at the NMC office to manage and supervise the overall system: monitoring and tracking of vehicle movement on a regular basis, tracking of complaints and inefficiencies, and generating daily and weekly reports. The redressal of complaints was done with the support of the sanitary inspectors at ward level.

### Outcome:

- Installations of GPS systems on all 124 *ghantagadis* owned by NMC, and centralised monitoring unit was created at NMC headquarter.
- Skill development and capacity building of the ground staff and contractors engaged in collection of municipal solid waste was undertaken when the system was introduced.
- Ensuring that the time delay and average stoppage time (4–5 minutes) for each vehicle was tracked.
- Effective and timely redressal of complaints was generated through the GPS monitoring system by the ward level sanitary staff.
- Generation of daily and weekly reports by vehicles to ensure adherence to the timing and collection of waste at the respective collection points.
- Information, transparency and data availability on the public domain for citizens and public representatives with respect to the routing and timings of the vehicles increased confidence in the system.

### Success Factor:

- Proactive role of NMC to streamline and monitor the collection and transportation system.
- Capacity building of the NMC staff, contractors, vehicle drivers, and workers was developed prior to the installation of the system.
- Collection of waste at a stipulated time by the contractors.
- Real time report generation through GPS helped in resolution of disputes among citizens, officials, and contractor, thereby creating a transparency between the consumers and service providers.

- Regular monitoring of the reports by the commissioner and the health officer resulted in the improvement in the collection and transportation efficiency.

**Overall Sustainability:**

By appointing an operator for regular O&M of the GPS system, NMC has ensured that the GPS machines and the monitoring system is functional and the initial teething troubles faced by NMC, because of dysfunctional or destruction of GPS machines installed in the ghantagadis, was overcome. The proactiveness of the commissioner and the Health Department of NMC towards transparency in municipal solid waste management ensured the sustainability of the system in the city.

*Source: Nashik Municipal Corporation (NMC)*

**6.1.3.1 RECORD KEEPING**

Based on the monitoring requirements specified in Table 6.1 and Table 6.2, ULBs need to maintain reports for all elements that need to be monitored. The Head of the MSWM department should review all reports along with the monitoring and evaluation (M&E) team. Monitoring and reporting proves to be extremely beneficial when the data generated are analysed effectively to improve performance.

Appropriate training and strengthening of capacities of existing staff is required to ensure accurate collection and reporting of data. Capacity building is required for all levels of staff; external support from experts may be sought to streamline and integrate M&E of all functions.

As stipulated by the Solid Waste Management (SWM) Rules, 2016, ULBs should report to the SPCB annually

**6.2 OPERATION AND MAINTENANCE PLAN FOR MUNICIPAL SOLID WASTE MANAGEMENT SERVICES**



As per SWM Rules, 2016:

**Clause 15: Duties and responsibilities of local authorities:-**

- (v) facilitate construction, operation and maintenance of solid waste processing facilities and associated infrastructure on their own or with private sector participation or through any agency for optimum utilisation of various components of solid waste adopting suitable technology including the following technologies and adhering to the guidelines issued by the Ministry of Urban Development
- (w) undertake on their own or through any other agency construction, operation and maintenance of sanitary landfill and associated infrastructure as per Schedule 1 for disposal of residual wastes in a manner prescribed under these rules;
- (x) make adequate provision of funds for capital investments as well as operation and maintenance of solid waste management services



in the annual budget ensuring that funds for discretionary functions of the local body have been allocated only after meeting the requirement of necessary funds for solid waste management and other obligatory functions of the local body as per these rules;

Irrespective of whether the provision of services is by the ULB or private contractor, an operation and maintenance (O&M) plan should be prepared and followed. The O&M plan should be drafted by the authority responsible for procurement and management of equipment or facilities; this authority could be either the ULB or the private operator, depending on the contractual conditions for the equipment or facility. O&M plans developed by private operators should be ratified by ULB's MSWM department.

The O&M plan should include preventive maintenance schedules, responsibilities and also guidance for breakdown maintenance. It should be the responsibility of the supervisor from the ULB and the operator to regularly maintain and update the O&M plan and use it as an instrument for monitoring. The plan should also indicate procedures for recording, reporting, analysis, and further action.

Preventive O&M of equipment, vehicles, and facilities ensures the long term sustainability of MSWM service provision. All contracts to private sector players, irrespective of the mode of contracting, should include a provision for O&M of all vehicles, equipment, and installations during the period of the contract. The term of the contract should be co-terminus with the expected life of the vehicles and equipment, particularly where the contractor is expected to invest in the procurement of vehicle and equipment.



### **Operation and Maintenance of Municipal Solid Waste Management Services**

- Regular operation and maintenance (O&M) of vehicles and equipment used for MSWM services ensures reduction in downtimes, thereby ensuring continual operation.
- Timely availability of required spares (including high wear and tear components, and critical components with long lead times for procurement) can be done easily through regular monitoring and maintenance.
- Preventive O&M provides financial planners with necessary timely budget and information to finance additional spares, equipment, and vehicles as maybe required.
- Preventive maintenance of equipment and fleet required for different activities (such as primary collection, secondary collection and transportation, transfer station, processing site, and landfill) ensures their continuous utility at full capacity throughout their design life.

#### **Key Components of an Operation and Management Plan:**

- O&M plan should address critical components subject to high wear and tear, avoiding potential cost implications of breakdown maintenance.

- The O&M plan should be prepared at the time of procurement by the authority, and schedule of preventive maintenance should be determined and strictly observed.
- O&M records should be maintained for all equipment. An analysis of this information will indicate critical issues of frequent breakdowns and components undergoing regular wear and tear. Supervisors could use this information to identify incorrect operating practices leading to frequent breakdowns. This analysis could also lead to the identification of equipment which is ill-suited to perform the requisite tasks and which needs replacement.
- The O&M plan should include contact information of concerned staff responsible for maintenance of specific equipment.
- Management personnel should periodically review this information to refine maintenance plans for individual vehicles and to identify improvements to the overall maintenance program.
- The effectiveness of the O&M plan can be measured by observing plant or machinery downtimes and the working conditions of the vehicle fleet.



### Good Operating Principles for Waste Processing, Treatment, and Disposal Facilities

- Adequate and appropriate human resource available for operating the waste management facility with due consideration to minimum qualification of key employees, supervisor, and operators.
- Regular capacity building and hands-on training of staff.
- Regular inspection of facility by superior staff and ensuring timely corrective measures.
- Mechanism for reporting unacceptable or prohibited activities on sites.
- Mechanism for reporting accidents and mishaps, with recorded investigative processes, follow-up actions, and periodic analysis of mishaps to identify danger areas or weaknesses in the process, system, or equipment.
- Scheduled environmental monitoring as per Solid Waste Management (SWM) Rules, 2016 and other applicable norms.

Standard operating procedures (SOP) and manuals for all technical processes, procedures, and equipment should be made available with the MSWM department

## 6.3 PREVENTIVE MAINTENANCE

Preventive maintenance is an essential part of the operation of collection equipment, machinery, and transportation vehicles to ensure their maximum life. However, there is a need to make a clear distinction between preventive maintenance and crisis maintenance. Preventive maintenance is carried out at a pre-defined time and on the basis of a disciplined schedule for maintenance, while crisis (or breakdown) maintenance is carried out when a fault develops.

Good preventive maintenance starts with the selection and specification of appropriate vehicles and equipment. Vehicles should be well-suited to predefined requirements and localised conditions, and should be

Preventive maintenance helps in identifying mechanical problems at an early stage and hence saves expenditure and minimises downtime

procured only after ascertaining ease of availability of spare parts (cost of spares should also be considered). Local availability of spare parts is often associated with reliability. Preventive maintenance schedule must be notified well in advance to all concerned parties and should be strictly enforced.

### 6.3.1 BENEFITS OF PREVENTIVE MAINTENANCE

An important aspect of a planned preventive maintenance programme is that it helps to take corrective measures well in advance, anticipates faults, and prevents a major breakdown which could endanger the safety of the personnel and entail huge cost. A preventive maintenance programme ensures that an advance notice is available for any requirement for spare parts, ensuring that equipment or vehicles are not out of service while the parts are being obtained. A planned preventive maintenance programme will not only help in keeping existing equipment operating at its maximum efficiency with minimum downtime but will also provide requisite information to financial planners, enabling them to include accurate forecasts of required expenditure for repairs, maintenance, and replacement of vehicles and equipment. Preventive maintenance programmes can change the institutional culture of the municipal administration, where breakdowns will no longer be seen as a regular routine.

#### Accountability and Responsibility for Preventive Maintenance

Preventive maintenance imposes responsibility and accountability at various levels (drivers, store in-charge, mechanics, workshop managers, etc.) for breakdowns and delays in repairs after a breakdown. Delays in procuring spares may also be due to a lack of funds, for which the financial controller or officer may be accountable.



Preventive maintenance programmes tend to change the institutional culture of municipal administration: breakdowns are no longer seen as a regular matter

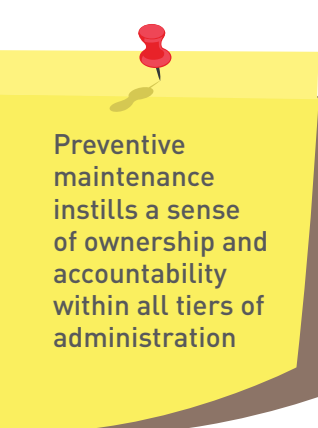

Preventive maintenance instills a sense of ownership and accountability within all tiers of administration



#### Example of a Preventive Maintenance Schedule for Vehicles

- Daily checks carried out by drivers.
- Weekly servicing checks by a junior mechanic highlights issues which a driver may not be able to identify or indicate if the daily checks are not effective.
- Monthly service check by a senior mechanic reveal any inadequacies in the weekly checks.
- The six monthly checks identify issues which have not been identified or addressed by the monthly checks.

The success of a preventive maintenance programme is indicated by fleet and equipment availability on any day. It can be indicated by calculating the number of vehicles (perhaps of a particular type) that are ready for service on any particular day, divided by the total number

of vehicles in the current fleet. The numbers could indicate the condition of the vehicles and whether the maintenance programme is improving or weakening. Availability levels can be used to show the number of standby vehicles that are needed (for each type of vehicle) and which types of vehicle are more reliable.

Management personnel should periodically review this information to refine maintenance plans for particular vehicles and to identify improvements to the overall maintenance program.

Similar systems should be in place for monitoring the downtimes and availability of other equipment and machinery used for all MSWM activities. MSWM processing, treatment, and disposal facilities should be encouraged to maintain records to ensure minimum downtime.

## 6.4 COMPLAINT REDRESSAL SYSTEM

A complaint redressal system creates a platform for citizens to voice their complaints and grievances regarding provision of MSWM services and also helps in promoting efficiency and transparency at the ULB level. The ULB, through an analysis of the complaints or grievances it receives, is able to identify lacunae and bridge gaps in service delivery. The time taken for resolution of grievances and the action taken are also monitored and recorded through this system. Typically, ULBs have a common complaint redressal system for all municipal services.

A complaint redressal system is effectively supported through the introduction of a citizen charter. The citizen's charter is a written voluntary declaration by a ULB with the basic objective to empower the citizens to get public service in a given time frame.

The Citizen's Charter includes:

- information on municipal services and expected outcomes,
- municipal service delivery standards,
- response time for rendering services or redressing grievances,
- information dissemination process on the complaint redressal process, and
- contact details of officers responsible for provision of the various municipal services.

The citizen's charter should be prepared by the ULB and officially adopted by the municipal council or committee and widely publicised. Urban development or local government departments may prepare a model citizen's charter to be adopted by all ULBs in the state after preparing city-specific citizen's charters for their own city.



A complaint redressal system is an effective tool which facilitates effective complaint management and expedites the redressal process in a transparent manner

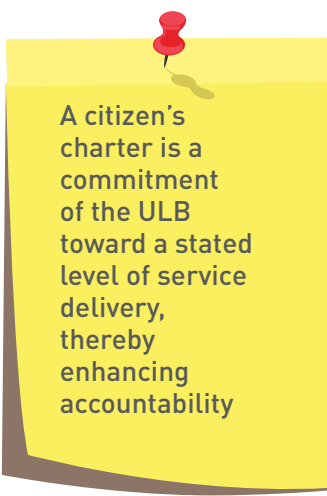

A citizen's charter is a commitment of the ULB toward a stated level of service delivery, thereby enhancing accountability

## 6.4.1 ELEMENTS OF A COMPLAINT REDRESSAL SYSTEM

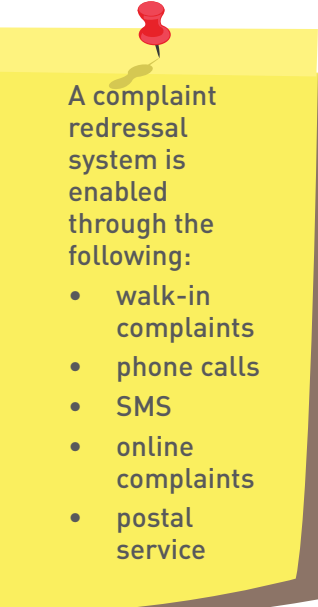

A complaint redressal system is enabled through the following:

- walk-in complaints
- phone calls
- SMS
- online complaints
- postal service

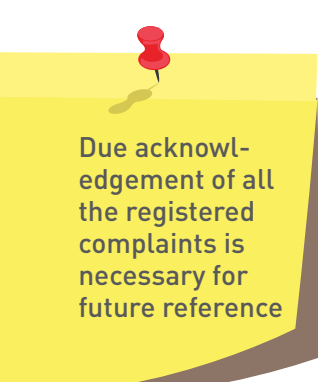

Due acknowledgement of all the registered complaints is necessary for future reference

Typical elements of a complaint redressal system include the following:

1. **Complaint management system:** A computerised central complaint management system should be networked to all the zonal or ward level complaint centers. In small ULBs, the complaints could be recorded through a register. A grievance redressal officer from the MSWM department or cell at senior level should be responsible for recording and monitoring the complaints and also for taking necessary actions for redressal.
2. **Medium of complaint registration:** Multiple channels or a combination of different channels may be adopted for receiving complaints, e.g., phone calls to a centralised customer service or complaint number, SMS messages to notified mobile numbers, automated generated complaints sent to commissioners for their records, walk-in complaint registration, and online complaint registration. Complaint registration through the postal service may be considered, if relevant, based on the demography and size of the ULB.
3. **Complaint registration and recording system:** This system should
  - assign a unique ID to each complaint generated;
  - record contact details of the complainant;
  - record details of the physical location (zone, ward, area) relevant to the complaint;
  - assign the complaint to the concerned official in the MSWM department or cell;
  - record the stipulated time within which the complaint shall be redressed;
  - provide an acknowledgement receipt to the complainant with all the above details, in case the complaint is registered manually or online; and
  - provide a complaint reference number with an SMS of registration to telephone-based complainants.
4. **Resolution certificate:** Field officers, after resolving the complaint, should take resolution certificate from the complainant and subsequently inform the complaint cell. The complaint shall thereafter be treated as resolved.
5. **Complaint resolution and feedback:** The designated official for complaint resolution in the MSWM department or cell shall be made aware of received complaints on a daily basis. Feedback could be taken through telephone, internet, SMS.
6. **Pending complaints:** Complaints which are not resolved in stipulated time shall be deemed pending. The reason for the pending complaint should be recorded and the designated officer and the



complainant should be duly informed. Such pending complaints should automatically be escalated to higher officials for monitoring and directions.

- 7. Reporting and complaint analysis:** A daily status report of complaint redressal should be prepared by an officer and submitted to the higher officer-in-charge for further directions. The complaint management system should generate periodic, area-wise reports on number of complaints received, nature of complaints, time taken for resolution, etc. The report should highlight the critical issues such as most frequently received complaints, frequently delayed responses, repetition of complaints (if any), time for resolution of complaints, etc. The weekly analysis of all complaints received should be reported to the chief executive officer or commissioner. Status of the complaints should be put in public domain and updated on a daily basis for ensuring transparency of the system.

## **6.5 ENVIRONMENTAL AND OCCUPATIONAL HEALTH MONITORING OF MUNICIPAL SOLID WASTE TREATMENT, PROCESSING AND DISPOSAL FACILITIES**

Environmental and occupational health monitoring of waste processing and disposal facilities is one of the most important aspects of overall management. For monitoring, collection and transportation, a number of tools have been already described (MIS, GIS, GPS, RFID, GPRS, etc.). When it comes to processing and disposal issues, additional tools are required in the form of standard operating procedure (SOP), which would be combined with MIS for proper operation and maintenance (O&M). In this case MIS would be designed to check if SOP for processing and disposal (sanitary landfilling) is being followed.

Annual audits supplemented by quarterly audits would be of great value. The following four types of audit would be necessary:

- 1. Compliance audit:** This audit checks the level and extent of compliance with the applicable regulations. In this case the applicable regulations are Solid Waste Management (SWM) Rules, 2016 (overall management including processing and sanitary landfill); and Fertilizer Control Order (FCO), 2009 (for compost quality standard) and 2013 (for quality standard of phosphate rich organic manure). There are other waste regulations which would also need to be audited for overall environmental compatibility of a city, such as Plastic Waste Management Rules, 2016; E-Waste Management Rules, 2016; Bio-Medical Waste Management Rules, 2016.

The prescribed authority, i.e., the State Pollution Control Board (SCPB) or Pollution Control Committee (PCC), is mandated to

carry out these compliances except FCO, 2009 and 2013, which are under the concerned state agriculture department.

However, it would be desirable that the concerned ULB and the build–operate–transfer (BOT) operator or any other concessionaire get these compliances audited through their respective internal audit mechanism. This would lead to better performance and voluntary improvements.

2. **Resource management audit:** This audit checks how efficiently the resources are deployed. Water, energy, material resources (e.g., diesel), and staffing are crucial factors for smooth operation and long-term sustainability.
3. **Operational risk audit:** This audit brings out the consequences of operational risks and frequency with which these risks may occur, including constraint in necessary supplies, environmental damage, and preventive measures.
4. **Occupational risk audit:** This audit checks the measures for occupational safety. It is best done as per Occupational Health and Safety Assessment Series (OHSAS 18001) norms, which are accepted as standard norms across the globe. These are based on hazard identification, risk assessment, and determination of applicable controls.

The above audits have a significant impact on performance of the tasks related to waste management and ensure long-term sustainability along with environmental compatibility. Training and awareness generation are important adjuncts to achieving these goals.

### 6.5.1 ENVIRONMENTAL MONITORING AS PER SOLID WASTE MANAGEMENT RULES, 2016

SWM Rules, 2016 stipulate regular monitoring of soil, water, and air quality around the municipal waste processing, treatment, and disposal facility. Schedules I, II, III, and IV of SWM Rules stipulate environmental norms for treatment, processing, and disposal facilities. Operators of MSW treatment, processing, and disposal facilities are responsible for regular monitoring of these parameters. Monitoring data should be reported to the SPCB by the ULB on an annual basis, as part of the annual reporting of ULBs. The MSWM service monitoring framework of the ULB should capture this information on a regular basis. The SPCB should monitor the compliance of standards for groundwater, ambient air, leachate, compost quality, and incineration as specified under schedules I and II (refer Section 3.2, 3.3 and 4.1 of Part II).



SWM Rules, 2016 indicate specific requirements for siting, operating and monitoring different MSWM technologies, such as composting and landfilling

The SWM Rules, 2016 also specify environmental monitoring requirements for designing, disposal, treatment and processing facilities, to ensure pollution prevention and environmentally sound operation of these facilities. These specifications are detailed out in Section 3.2.1, 3.2.12, 3.3.13, 3.5.9, 3.6 and 4.1 of Part II.

## 6.5.2 REPORTING REQUIREMENTS



SWM Rules, 2016 specify reporting requirements for the State Level Advisory Body and Local Authorities:

**Clause 15(za)** prepare and submit annual report in Form IV on or before the 30<sup>th</sup> April of the succeeding year to the Commissioner or Director, Municipal Administration or designated Officer;

(zb) the annual report shall then be sent to the Secretary-in-Charge of the State Urban Development Department or village panchayat or rural development department and to the respective State Pollution Control Board or Pollution Control Committee by the 31<sup>st</sup> May of every year;



**Clause 23: State Level Advisory Body:-**

(2) The State Level Advisory Body shall meet at least one in every six months to review the matters related to implementation of these rules, state policy and strategy on solid waste management and give advice to state government for taking measures that are necessary for expeditious and appropriate implementation of these rules.

(3) The copies of the review report shall be forwarded to the State Pollution Control Board or Pollution Control

Committee for necessary action.



**Clause 24: Annual Report:-**

(1) The operator of facility shall submit the annual report to the local body in Form-III on or before the 30<sup>th</sup> day of April every year.

(2) The local body shall submit its annual report in Form-IV to State Pollution Control Board or Pollution Committee and the Secretary-in-Charge of the Department of Urban Development of the concerned State or Union Territory in case of metropolitan city and to the Director of Municipal Administration or Commissioner of Municipal Administration or Officer in -Charge of Urban local bodies in the state in case of all other local bodies of state on or before the 30<sup>th</sup> day of June every year

(3) Each State Pollution Control Board or Pollution Control Committee as the case may be, shall prepare and submit the consolidated

annual report to the Central Pollution Control Board and Ministry of Urban Development on the implementation of these rules and action taken against non complying local body by the 31<sup>st</sup> day of July of each year in Form-V.

- (4) The Central Pollution Control Board shall prepare a consolidated annual review report on the status of implementation of these rules by local bodies in the country and forward the same to the Ministry of Urban Development and Ministry of Environment, Forest and Climate Change, along with its recommendations before the 31<sup>st</sup> day of August each year.
- (5) The annual report shall be reviewed by the Ministry of Environment, Forest and Climate Change during the meeting of Central Monitoring Committee.



#### Clause 25: Accident reporting-

In case of an accident at any solid waste processing or treatment or disposal facility or landfill site, the Officer- in- charge of the facility shall report to the local body in Form-VI and the local body shall review and issue instructions if any, to the in- charge of the facility.

## 6.6 TRAINING REQUIREMENTS FOR MONITORING MUNICIPAL SOLID WASTE SERVICE PROVISION



As per SWM Rules, 2016:

Clause 15(zc) educate workers including contract workers and supervisors for door to door collection of segregated waste and transporting the unmixed waste during primary and secondary transportation to processing or disposal facility;

Suitably qualified sanitary supervisors, sanitary inspectors, chief sanitary inspectors, and responsible officer-in-charge are to be trained in the basics of MSWM service provision. Their training requirements are listed below:

- They should be made aware of the data requirements for monitoring MSWM service provision. The importance of regular data collection and record keeping should be emphasised. They should also be made aware of the different sources of data required.
- They should be trained in data analysis to be able to effectively use data for monitoring the performance of the system.
- Skills of all staff of the MSWM department should be regularly upgraded for understanding of and effective use of the management information system (MIS).

## **6.7 ACTION POINTS FOR AWARENESS GENERATION THROUGH INFORMATION, EDUCATION, AND COMMUNICATION ACTIVITIES FOR MONITORING MUNICIPAL SOLID WASTE SERVICE PROVISION**

- Inform community of the scope and need for involvement in monitoring MSWM service provision.
- Publicise the citizen's charter for service provision to enhance accountability and details of the complaint redressal mechanism.
- Specify role of the ward committees in monitoring MSWM service provision and publicise contact details of ward committee members.
- Introduce local sanitary workers and supervisors to residents and owners of commercial establishments to enhance compliance from citizens and accountability of staff, which are a spin-off of increased interactions.
- Inform citizens about the institutionalisation of monitoring and reporting systems.
- Conduct quarterly community level meetings to discuss findings from the monitoring and reporting system and maintain a ward level service provision report card.



# **Management of Special Waste**

Including Domestic  
Hazardous Waste

## IN THIS SECTION

|      |  |     |
|------|--|-----|
| 7.1  | Introduction to Special Waste Including Domestic Hazardous Waste   | 495 |
| 7.2  | Existing Rules for Management of Special Waste Including Domestic Hazardous  | 495 |
| 7.3  | Special Waste Management including domestic hazardous waste – Guidance From the Integrated Solid Waste Management (ISWM) Framework                       | 498 |
| 7.4  | Plastic Waste  | 498 |
| 7.5  | Bio-medical Waste  | 509 |
| 7.6  | Slaughterhouse Waste   | 511 |
| 7.7  | Electric and Electronic Waste  | 516 |
| 7.8  | Waste Tyres  | 519 |
| 7.9  | Lead Battery Waste   | 521 |
| 7.10 | Action Points for Awareness Generation Through Information, Education, and Communication Activities for Special Waste Including Domestic Hazardous Waste | 522 |



## 7. MANAGEMENT OF SPECIAL WASTE INCLUDING DOMESTIC HAZARDOUS WASTE

### 7.1 INTRODUCTION TO SPECIAL WASTE INCLUDING DOMESTIC HAZARDOUS WASTE

Special waste including domestic hazardous waste comprises of any solid waste or a combination of solid wastes that requires special handling and disposal because of its quantity, concentration, physical and chemical characteristics, or biological properties, in order to protect human health, as well as the environment and to exploit its potential for recycling.

In line with this definition, the following waste are defined as special waste:

1. Plastic waste
2. Bio-medical waste
3. Slaughterhouse waste
4. Electric and electronic waste (e-waste)
5. Waste tyres
6. Battery waste

Special waste including domestic hazardous waste should not enter the municipal solid waste (MSW) streams. But these wastes are also generated at the household and commercial level and, due to lack of segregation at source or improper collection systems, they frequently end up in the mixed MSW stream.

### 7.2 EXISTING RULES FOR MANAGEMENT OF SPECIAL WASTE INCLUDING DOMESTIC HAZARDOUS WASTE



The various rules notified for environmentally sound management of different types of special wastes including domestic hazardous waste are discussed briefly in Table 7.1. Copies of all the rules of the Ministry of Environment, Forests & Climate Change (MoEFCC), which govern the management of such wastes, are included in Annexure 9, 11, 12, 14 and 15 of the manual.



Special waste including domestic hazardous waste requires special handling and disposal due to its physical and chemical characteristics

**Table 7.1: Existing Rules for Treatment of Special waste**

| LAWS AND REGULATIONS   | MAJOR CONTENTS  | TYPE OF WASTE             |
|--|---|---------------------------|
| <p>Plastic Waste Management Rules, 2016<sup>1</sup></p> <p>Guidelines for Recycling of Plastics (Indian Standards [IS] 14534), 1998<sup>2</sup></p> <p>Guidelines on Co-processing in Cement/Power/Steel Industry, February 2010<sup>3</sup></p> | <p>The manufacture, importer stocking, distribution, sale, and use of carry bags, plastic sheets or like, or cover made of plastic sheet, and multilayered packaging is regulated by this rule. Requirements for management of plastic waste are also specified in this rule. Norms for labelling plastic bags and recycled plastic products (not less than 50 microns in thickness); and recycling, recovery, or disposal of plastic waste are to be carried out as per the rules and standards notified by the central government.</p> <p>Guidelines for co-processing has relevance for both hazardous and non-hazardous waste (plastic and tyres) and are therefore mentioned with special reference to utilisation of non-hazardous waste in cement or power industry.</p>   | <p>Plastic wastes</p>     |
| <p>Bio-Medical Waste (Management and Handling) Rules, 1998<sup>4</sup> Draft Bio-Medical Waste (Management and Handling) Rules, 2011<sup>5</sup> and The Bio-Medical Waste Management Rules, 2016<sup>6</sup></p>                                | <p>According to these rules, the 'occupier' (a person who has control over the concerned institution or premises) of an institution generating bio-medical waste is responsible for ensuring that such waste is handled without any adverse effect to human health and the environment. The rules govern the categorisation, on-site, and off-site storage, transport, treatment, and disposal of bio- medical wastes.</p> <p>The Bio-Medical Management Rules, 2016 mandates every occupier to obtain authorisation irrespective of the number of patients being treated; Bio-medical waste has now been classified in to 4 categories instead 10 to improve the segregation of waste at source; and specifies colour coding for various categories of bio-medical waste to avoid overlapping; establish a Bar-Code System for bags or containers containing bio-medical waste for disposal. The new rules prescribe more stringent standards for incinerator and existing incinerators to achieve the standards for retention time in secondary chamber and Dioxin and Furans within two years;</p> | <p>Bio-medical wastes</p> |

1 Plastic Waste Management Rules, 2016. Available at: <http://www.moef.gov.in/sites/default/files/PWM%20Rules%2C%202016.pdf> (accessed on 20<sup>th</sup> April, 2016)

2 Guidance for Recycling of Plastics, 1998. Available at: <http://www.moef.nic.in/legis/hsm/plastic.html>

3 CPCB (2010), Guidelines on Co-processing in Cement/Power/Steel Industry. Available at: [http://cpcb.nic.in/upload/Latest/Latest\\_51\\_GUIDELINES-ON\\_CO-ProcessinginCement.pdf](http://cpcb.nic.in/upload/Latest/Latest_51_GUIDELINES-ON_CO-ProcessinginCement.pdf)

4 Bio-medical Waste (Management and Handling) Rules, 1998. Available at: <http://envfor.nic.in/legis/hsm/biomed.html>

5 Draft Bio-medical Waste (Management and Handling) Rules, 2011. Available at: [http://www.cpcb.nic.in/wast/bioimedicalwast/DraftBio-medicalWaste\(M&H\)Rules,2011.pdf](http://www.cpcb.nic.in/wast/bioimedicalwast/DraftBio-medicalWaste(M&H)Rules,2011.pdf)

6 The Bio-Medical Waste Management Rules, 2016. Available at: [http://www.moef.gov.in/sites/default/files/BMW%20Rules%2C%202016\\_0.pdf](http://www.moef.gov.in/sites/default/files/BMW%20Rules%2C%202016_0.pdf) (accessed on 20<sup>th</sup> April, 2016)

7 E-Waste (Management) Rules, 2016. Available at: <http://www.moef.gov.in/sites/default/files/EWM%20Rules%202016%20english%2023.03.2016.pdf> (accessed on 20<sup>th</sup> April, 2016)

**Table 7.1: Existing Rules for Treatment of Special waste [contd.]**

| LAWS AND REGULATIONS   | MAJOR CONTENTS   | TYPE OF WASTE  |
|--|--|--|
| E-Waste Management Rules, 2016 <sup>7</sup>  | These Rules are based on the principles of extended producer responsibility (EPR), wherein the producer engaged in the manufacture, sale, and purchase of electrical and electronic equipment is responsible for the end of life management of the electrical and electronic products listed in Schedule 1 of the rules. Procedures are provided for handling E-Waste as applicable to all stakeholders, such as collection centres, dismantlers, and recyclers of E-Waste. Stipulations for reducing the hazardous substances in electrical and electronic equipment are also prescribed. Procedures and formats for registration of facilities for recycling E-Waste are specified.  | E-Wastes (electrical and electronic wastes)  |
| Batteries (Management and Handling) Rules, 2001 <sup>8</sup>   | These rules are for regulating the recycling of lead acid batteries after use. The rules specify responsibilities of manufacturers, importers, assemblers, dealers, and re-conditioners of lead acid batteries, which are a source of electrical energy and contain lead. Requirements for registration of recyclers are prescribed under the rules. The rules also provide a control on the imports of substances by original equipment manufacturers and other equipment manufacturers.  | Lead acid batteries  |
| Hazardous Wastes (Management and Handling) Rules, 1998 and Hazardous and Other Wastes (Management and Transboundary Movement) Rules, 2016 <sup>9</sup> | The ambit of the Rules has been expanded by including 'Other Waste'. These rules are applicable to hazardous wastes and other waste as defined and listed in the rules; the rules specifies the procedure for management of hazardous and other waste, obligations of the occupier generating the hazardous and other waste, the process for grant of authorisation for handling such wastes from the State Pollution Control Board (SPCB) or Pollution Control Committees (PCC) and its procedure has been simplified to merge all the approvals as a single window clearance for setting up of hazardous and other waste disposal facility and import of other wastes; Requirements for packaging, labeling, and transport and strategy for import and export of hazardous and other wastes are also mentioned in the rules. The process for suspension or cancellation of licenses of generators and restrictions on the import of these wastes are also specified. The responsibility of the state government to inventorise all hazardous waste generators and the requirements for record keeping and reporting by the operator and the SPCB or PCC are mentioned. Co-processing as a preferential mechanism over disposal for use of waste as supplementary resource, or for recovery of energy has been provided and the approval process for co-processing for waste to energy recovery has been streamlined; the basic necessity of infrastructure to safeguard the health and environment from waste processing industry has been prescribed as Standard Operating Procedure (SOPs) specific to waste type. | Waste streams from process generating hazardous wastes as mentioned in Schedule I of the Amendment Rules, 2000 |
| Note: Hazardous Waste is not commonly found in municipal waste streams and hence its management is not described in detail in this manual.             |  |  |

## 7.3 SPECIAL WASTE MANAGEMENT INCLUDING DOMESTIC HAZARDOUS WASTE – GUIDANCE FROM THE INTEGRATED SOLID WASTE MANAGEMENT (ISWM) HIERARCHY

The integrated solid waste management (ISWM) hierarchy (Section 1.1 of Part II) indicates that the next preferred waste management method to waste minimisation or reduction is reuse and recycling. Waste that cannot be reduced or minimised should be reused (resource recovery) and recycled. Some special wastes including domestic hazardous waste like plastics waste, electrical and electronic waste (e-waste) can be reused or recycled; on the other hand, slaughterhouse waste and bio-medical waste should not be recycled and should be appropriately treated and disposed of to prevent hazardous impacts of undesirable dumping of these wastes.

Recycling of special wastes including domestic hazardous waste provides economic as well as environmental benefits and reduces reliance on virgin materials.

## 7.4 PLASTIC WASTE

The disposal of plastic waste is legislated under the Plastic Waste Management Rules, 2016. These rules specify the responsibilities of urban local bodies (ULBs) for managing plastic waste. However, most of the discarded plastics find their way into the municipal waste streams.

### 7.4.1 EXCERPTS FROM THE PLASTIC WASTE MANAGEMENT RULES, 2016



Clause 4: The manufacture, importer stocking, distribution, sale and use of carry bags, plastic sheets or like, or cover made of plastic sheet and multilayered packaging, shall be subject to the following conditions, namely:-

- a) carry bags and plastic packaging shall either be in natural shade which is without any added pigments or made using only those pigments and colourants which are in conformity with Indian Standard : IS 9833:1981 titled as “List of pigments and colourants for use in plastics in contact with foodstuffs, pharmaceuticals and drinking water”, as amended from time to time;

8 Batteries (Management and Handling) Rules, 2001. Available at: <http://www.moef.nic.in/legis/hsm/leadbat.html>

9 Hazardous Wastes (Management and Handling) Amendment Rules, 2000 Available at: <http://envfor.nic.in/legis/hsm/hwamdr.html>  
Hazardous and Other Wastes (Management and Transboundary Movement) Rules, 2016 <http://www.moef.gov.in/sites/default/files/Final%20HWM%20Rules%202016%20%28English%29.pdf>

- b) Carry bags made of recycled plastic or products made of recycled plastic shall not be used for storing, carrying, dispensing or packaging ready to eat or drink food stuff;
- c) carry bag made of virgin or recycled plastic, shall not be less than fifty microns in thickness;
- d) plastic sheet or like, which is not an integral part of multilayered packaging and cover made of plastic sheet used for packaging, wrapping the commodity shall not be less than fifty microns in thickness except where the thickness of such plastic sheets impair the functionality of the product;
- e) the manufacturer shall not sell or provide or arrange plastic to be used as raw material to a producer, not having valid registration from the concerned State Pollution Control Boards or Pollution Control Committee;
- f) sachets using plastic material shall not be used for storing, packing or selling gutkha, tobacco and pan masala;
- g) recycling of plastic waste shall conform to the Indian Standard: IS 14534:1998 titled as Guidelines for Recycling of Plastics, as amended from time to time;
- h) The provision of thickness shall not be applicable to carry bags made up of compostable plastic. Carry bags made from compostable plastics shall conform to the Indian Standard: IS 17088:2008 titled as Specifications for Compostable Plastics, as amended from time to time. The manufacturers or seller of compostable plastic carry bags shall obtain a certificate from the Central Pollution Control Board before marketing or selling; and
- i) plastic material, in any form including Vinyl Acetate - Maleic Acid - Vinyl Chloride Copolymer, shall not be used in any package for packaging gutkha, pan masala and tobacco in all forms.



**Clause 5: The plastic waste management by the urban local bodies in their respective jurisdiction shall be as under:-**

- (a) plastic waste, which can be recycled, shall be channelized to registered plastic waste recycler and recycling of plastic shall conform to the Indian Standard: IS 14534:1998 titled as Guidelines for Recycling of Plastics, as amended from time to time.
- (b) local bodies shall encourage the use of plastic waste (preferably the plastic waste which cannot be further recycled) for road construction as per Indian Road Congress guidelines or energy recovery or waste to oil etc. The standards and pollution control norms specified by the prescribed authority for these technologies shall be complied with.

- (c) Thermo set plastic waste shall be processed and disposed off as per the guidelines issued from time to time by the Central Pollution Control Board.
- (d) The inert from recycling or processing facilities of plastic waste shall be disposed of in compliance with the Solid Waste Management Rules, 2000 or as amended from time to time.



#### Clause 6: Responsibility of local body.-

- (1) Every local body shall be responsible for development and setting up of infrastructure for segregation, collection, storage, transportation, processing and disposal of the plastic waste either on its own or by engaging agencies or producers.
- (2) The local body shall be responsible for setting up, operationalisation and co-ordination of the waste management system and for performing the associated functions, namely:-
  - (a) Ensuring segregation, collection, storage, transportation, processing and disposal of plastic waste;
  - (b) ensuring that no damage is caused to the environment during this process;
  - (c) ensuring channelization of recyclable plastic waste fraction to recyclers;
  - (d) ensuring processing and disposal on non-recyclable fraction of plastic waste in accordance with the guidelines issued by the Central Pollution Control Board;
  - (e) creating awareness among all stakeholders about their responsibilities;
  - (f) engaging civil societies or groups working with waste pickers; and
  - (g) ensuring that open burning of plastic waste does not take place.
- (3) The local body for setting up of system for plastic waste management shall seek assistance of producers and such system shall be set up within one year from the date of final publication of these rules in the Official Gazette of India.
- (4) The local body to frame bye-laws incorporating the provisions of these rules.



### Clause 8: Responsibility of waste generator:-

- (1) The waste generator shall.-
  - (a) take steps to minimize generation of plastic waste and segregate plastic waste at source in accordance with the Solid Waste Management Rules, 2000 or as amended from time to time.
  - (b) not litter the plastic waste and ensure segregated storage of waste at source and handover segregated waste to urban local body or gram panchayat or agencies appointed by them or registered waste pickers', registered recyclers or waste collection agencies;
- (2) All institutional generators of plastic waste, shall segregate and store the waste generated by them in accordance with the Municipal Solid Waste (Management and Handling) Rules, 2000 notified vide S.O. 908(E) dated the 25th September, 2000 under the Act or amendment from time to time and handover segregated wastes to authorized waste processing or disposal facilities or deposition centers either on its own or through the authorized waste collection agency.
- (3) All waste generators shall pay such user fee or charge as may be specified in the bye-laws of the local bodies for plastic waste management such as waste collection or operation of the facility thereof, etc.;
- (4) Every person responsible for organising an event in open space, which involves service of food stuff in plastic or multilayered packaging shall segregate and manage the waste generated during such events in accordance with the Municipal Solid Waste (Management and Handling) Rules, 2000 notified vide S.O. 908(E) dated the 25th September, 2000 under the Act or amendment from time to time.



### Clause 9: Responsibility of producers:-

- (1) The producers, within a period of six months from the date of publication of these rules, shall work out modalities for waste collection system based on Extended Producers Responsibility and involving State Urban Development Departments, either individually or collectively, through their own distribution channel or through the local body concerned.
- (2) Primary responsibility for collection of used multi-layered plastic sachet or pouches or packaging is of Producers, Importers and Brand Owners who introduce the products in the market. They need to establish a system for collecting back the plastic waste generated due to their products. This plan of collection to be submitted to the State Pollution Control Boards while applying for Consent to Establish or Operate or Renewal. The Brand Owners whose consent has been renewed before the notification of these rules shall submit

such plan within one year from the date of notification of these rules and implement with two years thereafter.

- (3) manufacture and use of non- recyclable multilayered plastic if any should be phased out in Two years time.
- (4) The producer, within a period of three months from the date of final publication of these rules in the Official Gazette shall apply to the Pollution Control Board or the Pollution Control Committee, as the case may be, of the States or the Union Territories administration concerned, for grant of registration.
- (5) No producer shall on and after the expiry of a period of Six Months from the date of final publication of these rules in the Official Gazette manufacture or use any plastic or multilayered packaging for packaging of commodities without registration from the concerned State Pollution Control Board or the Pollution Control Committees.
- (6) Every producer shall maintain a record of details of the person engaged in supply of plastic used as raw material to manufacture carry bags or plastic sheet or like or cover made of plastic sheet or multilayered packaging.

#### **7.4.2 COMPOSITION OF PLASTICS**

Plastics comprise of polymers which are distinct for each product. The most common are polyethylene terephthalate (PET), high-density polyethylene (HDPE), and low-density polyethylene (LDPE) as classified by Bureau of Indian Standards (BIS) and others mentioned in the box below. The Society of the Plastics Industry (SPI) has established the SPI resin identification coding system as a set of symbols placed on plastics to identify the polymer type. The code is used internationally and its primary purpose is to allow efficient separation of different polymer types for recycling.





### Classification of Plastics – Bureau of Indian Standards

Bureau of Indian Standards (BIS) classifies plastic into seven types.

| SYMBOL | SHORT NAME | SCIENTIFIC NAME            | USE IN  |
|--------|------------|----------------------------|---|
|        | PET        | Polyethylene terephthalate | Water bottles, PET bottles etc.   |
|        | HDPE       | High density polyethylene  | Milk or detergent bags, Carry bags, Container etc.  |
|        | PVC        | Polyvinyl chloride         | Cables, Pipes, Floorings etc.   |
|        | LDPE       | Low density polyethylene   | Carry bags, Films   |
|        | PP         | Polypropylene              | Medicine bottles, Cereal liners, Packaging films etc.   |
|        | PS         | Polystyrene                | Foam packaging, Tea cups, Ice cream cups, etc.  |
|        | 0          | Others                     | Thermoset plastics, Multilayer and Laminated Plastics, PUF, Bakelite, Polycarbonate, Melamine, Nylon etc. |

Source: BIS, CPCB

- Recyclable plastics (thermoplastics): PET, HDPE, LDPE, PP, PVC, PS, etc.
- Non-recyclable plastics (thermoset and others): Multilayer and laminated plastics, polyurethane foam (PUF), bakelite, polycarbonate, melamine, nylon, etc.

Extensive use of plastic leads to the generation of huge quantities of plastic wastes that may account for 1%–10% (by volume) of the total municipal solid wastes (MSW). India produces approximately 8 million tonnes of plastic products every year (2008).<sup>10</sup> Plastic is used for several purposes (wrapping material, shopping and garbage bags, fluid containers, clothing, toys, household and industrial products, building materials, etc.). Plastic cannot be recycled indefinitely and, eventually, all plastic products end up as waste since virgin plastic material can be recycled 2–3 times only and the plastic material deteriorates due to thermal pressure after each recycling. Plastics are also highly resistant to biodegradation.

### 7.4.3 PLASTIC WASTE MANAGEMENT

Following the integrated solid waste management (ISWM) hierarchy, reuse and recycling of plastic waste are the preferred methods for managing plastic wastes after reduction. However, as mentioned, plastics cannot be recycled indefinitely; each recycling cycle reduces the strength and utility of the plastic. Energy recovery from plastics

10 Material on Plastic Waste Management. Chapter – 1: Annual Report (2011-12) on Implementation of PWM. CPCB (2013). [http://www.cpcb.nic.in/divisionsofheadoffice/pcp/management\\_plasticwaste.pdf](http://www.cpcb.nic.in/divisionsofheadoffice/pcp/management_plasticwaste.pdf)

Plastic waste choke the urban drainage system, causing urban flooding in many instances. Immediate action on appropriate management (focusing on minimisation) and disposal of these wastes is required



shall be considered when recycling is no longer possible. Plastic waste is accepted as fuel in cement kilns; residence times and temperatures are adequate to preempt the production of dioxins and furans. Incineration of plastic wastes for energy recovery may also be considered under strictly controlled and monitored conditions (for further details, refer to Section 3.3.2 of Part II). Reusing plastic waste to form polymer blended bitumen roads is an accepted method for final disposal of plastics in India. Landfilling of plastics should be avoided.

Plasma pyrolysis and production of liquid fuel from plastic waste are technologies being tested; however, commercial viability of such technologies is yet to be proven. The flowchart in Figure 7.1 depicts available options for plastic waste management, in order of their preference. Conventional technologies are more reliable than technologies still under development.

**Figure 7.1: Options for Plastic Waste Management<sup>11</sup>**

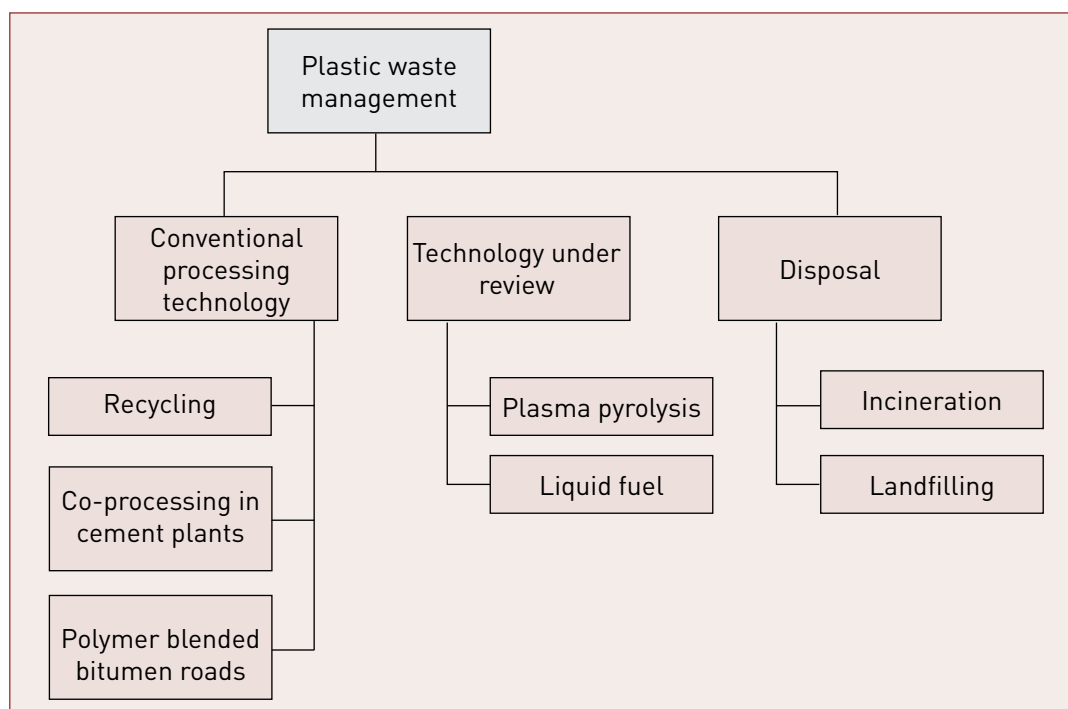

Plastic recycling processes which produce end products with a higher order of reuse (eg. reuse as a virgin material substitute) coupled with a longer product life should be preferred

Recycling processes should seek to minimise pollution and maximise efficiency including energy efficiency of the process for recycling these wastes

#### 7.4.4 RECYCLING OF PLASTIC WASTES

To a large extent, plastics are recyclable. Recycled polymers exhibit lower properties and performance than virgin polymers, and are useful only for lower value applications. Recycling of plastics without prior separation by resin produces a material with mechanical properties similar to timber. Hence, it is often used as a replacement for timber in certain applications. A higher quality of recycled plastics is achieved when separation by resin is carried out prior to the remoulding step.

11 Central Pollution Control Board. Available at: [http://www.cpcb.nic.in/wast/plasticwast/Plastic\\_waste-1.pdf](http://www.cpcb.nic.in/wast/plasticwast/Plastic_waste-1.pdf)



#### 7.4.4.1 STEPS INVOLVED IN THE RECYCLING PROCESS

**Collection:** Plastic waste should be collected from the door step from all MSW generators along with other reusable and recyclable non-biodegradable wastes and should be sorted out at intermediate sorting facilities or at the MSW processing facility.

**Segregation:** Plastic waste should be segregated from the rest of the recyclable waste based on different types of plastic, requiring different recycling processes.

**Processing:** After collection and segregation, post-consumer waste (used plastic waste) should be given away to recycling industry at a pre-negotiated price by the municipality. In cases where the municipal authority has already given the contract to a private operator to process MSW, plastic waste may be allowed to be processed or sold to the recycling industry by the operator following good industrial practices.

#### 7.4.5 SUSTAINABLE DISPOSAL OF PLASTIC WASTE

At a stage where further recycling is not possible, the plastic material or product should be disposed of by suitable methods. Safe disposal of plastics is possible through various technologies such as co-processing of plastic waste in cement kilns and utilisation of plastic waste in road construction.

#### 7.4.6 CO-PROCESSING AND CO-INCINERATION OF PLASTIC WASTE AS ALTERNATIVE FUEL AND RAW MATERIAL (AFR) IN CEMENT KILNS

Co-processing refers to the use of waste materials in the industrial process such as cement and power stations or any other large combustion plants. Co-processing indicates substitution of primary fuel and raw material by waste. Waste material such as plastic waste, multilayered packaging waste, etc. used for co-processing are referred to as alternative fuels and raw material. Co-incineration refers to utilisation of waste material for energy recovery.

Co-processing of plastic waste and multilayered packaging waste offers advantages for cement industry as well as for local authorities responsible for waste management. Producers save on fossil fuel and raw material consumption in co-processing, resulting in the adoption of eco-efficient production methods. Substituting fossil fuel and virgin raw material by alternative fuels and raw materials reduces overall carbon dioxide (CO<sub>2</sub>) emissions of the process (assuming that the waste material being used would instead have been burned or disposed of without energy recovery). So far its application has been successful in



Co-processing and co-incineration of plastic waste in cement industries are proven methods for substitution of raw material as well as for energy recovery

the cement industry, and municipal authorities are also benefitted since co-processing of plastic wastes is an efficient and environmentally safe method to manage a sizeable quantity of non-recyclable plastic waste in MSW.

The Central Pollution Control Board (CPCB) has prescribed guidelines on co-processing of plastic waste as an alternative fuel.<sup>12</sup> The defined protocol is summarised below in Table 7.2.

**Table 7.2: Central Pollution Control Board Guidance on Protocol for Co-processing of Plastic Waste<sup>13</sup>**

| SR. NO. | ITEM   | DESCRIPTION  | ACTION TO BE TAKEN BY  |
|---------|--|--|--|
| 1       | Collection of plastic waste  | Concerned municipal authority should create a system for collection of plastic wastes from dustbins or dhalaos through PPP mode or any other feasible method.  | Municipal corporation, municipality, municipal council, and cantonment board |
| 2       | Segregation & pre-processing of plastic waste                          | Collected plastics can be reprocessed or sorted into recyclable and non-recyclable fractions. The non-recyclable plastic wastes will be transported to nearest cement kilns and power plant for co-processing by concerned municipal authority in consultation with SPCB or PCC. | Municipal corporation, municipality, municipal council, and cantonment board |
| 3       | Identification of cement factory                                       | Mapping of cement kilns and power plant for accepting co-processing of plastic waste in the same state or neighbouring state. An agreement shall be signed between municipal corporations and cement kilns.  | SPCB, PCC, and municipal authorities   |
| 4       | Modification for feeding plastic waste in cement kilns or power plants | Cement industry or power plant is to set up storage facility, shredder, conveyor belt, one hopper, one winch machine, and one double-flap damper.  | Concerned cement industries or power plant                                   |
| 5       | Setting-up of laboratory for plastics waste analysis                   | Cement industry or power plant shall set up a minimum laboratory facility to analyse plastic wastes before co-processing. The instrumentation includes thermogravimetric analyser; bomb calorimeter; and C, H, N, S analyser.  | Concerned cement industry or power plant                                     |
| 6       | Monitoring of emission by cement industry or SPCBs                     | Cement industry or power plant shall monitor the stack emission with respect to routine parameters and hazardous air pollutants.   | Concerned cement industry, power plant, and SPCB or PCC                      |

12 Material on Plastic Waste Management. Chapter – 1: Annual Report (2011-12) on Implementation of PWM. CPCB. (2013). [http://www.cpcb.nic.in/divisionsofheadoffice/pcp/management\\_plasticwaste.pdf](http://www.cpcb.nic.in/divisionsofheadoffice/pcp/management_plasticwaste.pdf)

13 Material on Plastic Waste Management. Chapter – 1: Annual Report (2011-12) on Implementation of PWM. CPCB. (2013). [http://www.cpcb.nic.in/divisionsofheadoffice/pcp/management\\_plasticwaste.pdf](http://www.cpcb.nic.in/divisionsofheadoffice/pcp/management_plasticwaste.pdf)

**Table 7.2: Central Pollution Control Board Guidance on Protocol for Co-processing of Plastic Waste [contd.]**

| <b>SR. NO.</b> | <b>ITEM</b>                        | <b>DESCRIPTION</b>  | <b>ACTION TO BE TAKEN BY</b>                            |
|----------------|------------------------------------|---|---|
| 7              | Forwarding progress report to CPCB | Cement industry or power plant shall forward quarterly progress report of co-processing of plastic waste to CPCB. | Concerned cement industry, power plant, and SPCB or PCC |

## **7.4.7 OTHER PLASTIC WASTE DISPOSAL OPTIONS**

### **7.4.7.1 USE OF WASTE PLASTIC IN CONSTRUCTION OF BITUMINOUS ROADS**

The use of plastic waste in bitumen roads (Figure 7.2) has been found to have several advantages including decreasing the susceptibility of the road to infiltration. There are also no observed deleterious impacts on the strength or properties of the road.<sup>14</sup>

#### **Process Description:**

- Waste plastic bags collected from roads, garbage trucks, dumpsites, compost plants, waste pickers, waste buyers, and households can be utilised in this process. Here plastic waste is sorted as per its thickness and type. Polyethylene with a thickness greater than 60 microns is sent for recycling; polyethylene below 60 microns is to be used in this process. Plastic waste should be cleaned by de-dusting or washing if required.
- Collected plastic is cut and sized into fine pieces.
- Lower micron plastic mixes easily with bitumen at higher temperatures (160°C–170°C). Bitumen is heated up to its melting temperature (160°C–170°C). Finely sized plastic pieces are added slowly to the hot bitumen, and the mixture is stirred for about 20–30 minutes at the same temperature. Polymer–bitumen mixtures of different compositions are prepared and tested for their application in road construction.

14 Plastic Waste Management. CPCB (2013). Available at: [http://www.cpcb.nic.in/wast/plasticwast/Plastic\\_waste-1.pdf](http://www.cpcb.nic.in/wast/plasticwast/Plastic_waste-1.pdf)

Figure 7.2: Use of Plastic Waste in Construction of Bituminous Road<sup>15</sup>

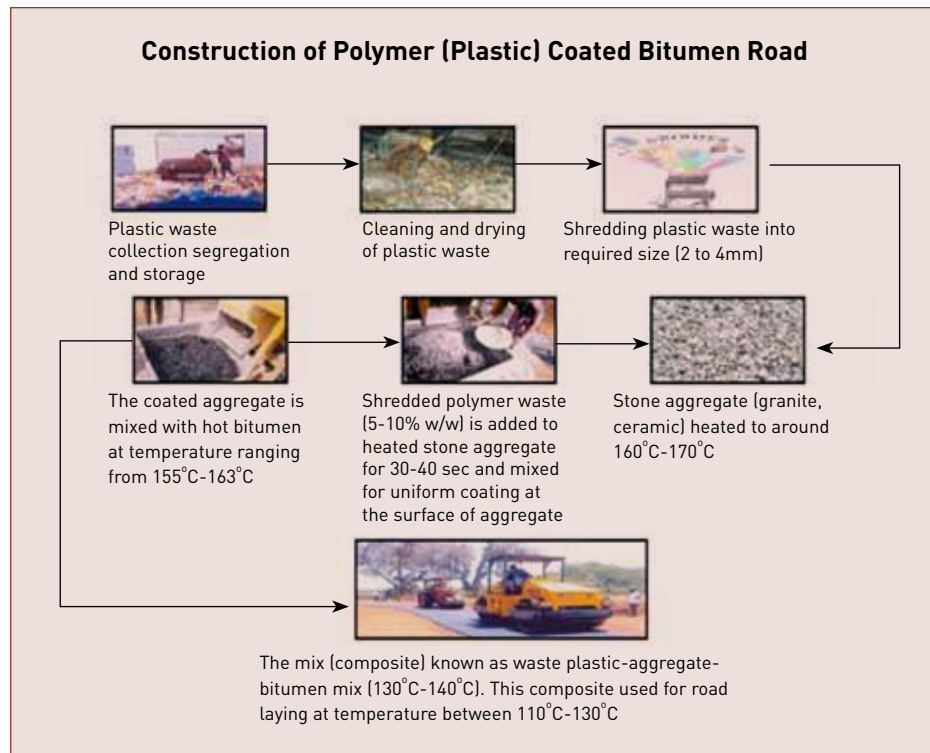

#### 7.4.7.2 CONVERSION OF PLASTIC WASTE INTO LIQUID FUEL

ULBs should not experiment with non-proven technologies

The conversion of plastic waste into liquid fuel has been considered as a possible solution for the disposal of plastic waste, however, it is still at its nascent stage. A research-cum-demonstration plant in Nagpur, Maharashtra converts waste plastics into liquid fuel. The process adopted is based on random de-polymerisation of waste plastics into liquid fuel in presence of a catalyst. The entire process is undertaken in closed reactor vessels followed by condensation. Waste plastics while heating up to 270°C to 300°C convert into liquid-vapour state, which is collected in condensation chambers in the form of liquid fuel while the tarry liquid waste is topped-down from the heating reactor vessel. Organic gas is generated, which is vented due to lack of storage facility. However, the gas can be used in dual fuel diesel-generator set for generation of electricity. This technology is at an experimental stage and may be considered only after it is well established as a technically, financially, and environmentally viable option of plastic waste processing or disposal.

15 Material on Plastic Waste Management, CPCB (2012). Available at: [http://www.cpcb.nic.in/divisionsofheadoffice/pcp/management\\_plasticwaste.pdf](http://www.cpcb.nic.in/divisionsofheadoffice/pcp/management_plasticwaste.pdf)



### **Plastic to Liquid Fuel: Initiative in New Moti Bagh, New Delhi**

Under a 'zero waste' project at the 'General Pool Residential Accommodation Complex (GPRA)' of the Ministry of Urban Development in New Moti Bagh, a small facility to convert plastic waste into liquid fuel has been installed. The facility handles 50 kilograms of plastic waste per batch. The plastic waste, collected from the staff quarters, is segregated and put through a pyrolytic conversion process at about 400°C in the presence of a catalyst. The large polymeric molecules break down into smaller fractions yielding liquid fuel (in the range of light diesel oil or furnace oil), gaseous fuel, and char, all of which can be further used for different purposes. The light diesel oil or furnace oil is of key interest for commercial purposes. However, environmental implications of the process in terms of emissions, as well as its commercial viability, need to be further established.

### **7.4.7.3 INCINERATION OF PLASTIC WASTE**

In cases where material recovery is not feasible, incineration with energy recovery is an accepted technology internationally for plastic waste disposal, with provision for adequate pollution abatement safeguards. Inappropriate operating conditions can cause the release of several harmful gases including dioxins and furans from chlorinated and brominated plastic waste. However, it is to be noted that achieving the requisite temperature and retention time in incinerators, coupled with an appropriate flue gas scrubbing or treatment system will ensure the safety of such technologies. For incineration technology, please refer to Section 3.3.3 of Part II.

## **7.5 BIO-MEDICAL WASTE**

“Bio-Medical Waste” means any waste, which is generated during the diagnosis, treatment or immunisation of human beings or animals or research activities pertaining thereto or in the production or testing of biological or in health camps, including the categories mentioned in Schedule I appended to these rules.

Waste from kitchen, store, residential facilities, and gardens of health care establishments that are free from bio-medical waste contamination can enter the municipal waste stream.

### **7.5.1 SOLID WASTE MANAGEMENT RULES, 2016 - REQUIREMENTS ON BIO-MEDICAL WASTE**



SWM Rules, 2016 prescribes that bio-medical wastes, industrial wastes, e-waste and domestic hazardous wastes shall be handled as specified in specific rules framed for management of such wastes and domestic hazardous waste may be handled as directed by the state pollution control board or pollution control committee.

As per the criteria for site selection given in Schedule I (x) of SWM Rules, 2016, the biomedical waste shall be disposed of in accordance with the Bio-medical Waste Management Rules, 2016, as amended from time to time.

The Schedule III of the Bio-medical Wastes Management Rules, 2016 mandates local authorities such as gram panchayats, municipalities or corporations to provide or allocate suitable land for setting up of Common Bio-Medical Waste Treatment Facility in their respective jurisdictions as per the guidelines of CPCB.

Collect other solid waste (other than the bio-medical waste) from the health care facilities as per the SWM Rules, 2016 or as amended time to time.



**Clause 17 Site for common bio-medical waste treatment and disposal facility.-**

- (1) Without prejudice to rule 5 of these rules, the department in the business allocation of land assignment shall be responsible for providing suitable site for setting up of common biomedical waste treatment and disposal facility in the State Government or Union territory Administration.
- (2) The selection of site for setting up of such facility shall be made in consultation with the prescribed authority, other stakeholders and in accordance with guidelines published by the Ministry of Environment, Forest and Climate Change or Central Pollution Control Board.

## **7.5.2 COLLECTION AND SEGREGATION OF WASTE IN HEALTH CARE ESTABLISHMENTS**



**Schedule I Part II of Bio-Medical Waste Management Rules, 2016:**

Bio-medical waste generated in households during healthcare activities shall be segregated as per these rules and handed over in separate bags or containers to municipal waste collectors. Urban Local Bodies shall have tie up with the common bio-medical waste treatment and disposal facility to pickup this waste from the Material Recovery Facility (MRF) or from the house hold directly, for final disposal in the manner as prescribed in this Schedule.

Due to its infectious and hazardous characteristics, bio-medical waste should be segregated from other municipal wastes at source and handled appropriately at collection and storage points in the health care establishments. Bio-medical waste has been classified into four categories as per the rule (2016), and different treatment or disposal systems have been indicated for them. Health care establishments such as hospitals, nursing homes, pathological laboratories etc., generate bio-medical waste as well



as MSW (especially from their kitchen, garden, recreational area, etc.). These wastes should be segregated at the point of generation and stored in the colour coded containers separately following the provisions of Bio-medical Waste (M&H) Rules, 1998 and as amended in 2011 and 2016. This way the load on the bio-medical waste treatment facility would be much less because, normally, this category of waste is hardly 25%–30% of the total waste generated by health care facilities. The bio-medical waste should be sent for further treatment and disposal as per Bio-medical Waste (M&H) Rules, 1998 and as amended in 2011 and 2016; other solid wastes should be handled in accordance with the SWM Rules, 2016. This is essential to ensure that MSW generated from health care establishments is not contaminated, and does not pose any health and environmental risks to the waste handlers, processing plants, and users of end products of MSW at processing facilities.

ULBs should collect MSW generated by hospitals and other health care establishments after ensuring that such waste streams are not contaminated with bio-medical wastes

## 7.6 SLAUGHTERHOUSE WASTE

Slaughterhouse waste is predominantly disposed in dump sites or processed along with other organic waste in compost plants which are not scientifically and properly managed. Scientific processing and disposal of slaughterhouse waste is essential to recover useful fractions and for safe disposal of residual pathogenic biological wastes.

Processes undertaken in a modern slaughterhouse include slaughtering, dressing, cutting, and inspection of meats, and refrigeration, curing, and manufacturing of by-products. In the absence of a proper slaughterhouse waste processing or disposal facility, urban local bodies (ULBs) can practice deep burial of carcasses and animals killed in accidents with adequate precaution. However, ULBs should regularly monitor sites where deep burial is practiced for potential environmental and public health impacts.

Based on scale of operations, slaughterhouses have been classified into three categories: large, medium, and small (Table 7.3).

Large slaughterhouses are mostly in cities. They generate substantial quantity of solid wastes that have to be processed in an environmentally acceptable manner.

**Table 7.3: Classification of Slaughterhouses<sup>16</sup>**

| CATEGORY | SLAUGHTERING CAPACITY (TONNES OF LIVE WEIGHT KILLED PER DAY) |
|----------|--|
| Large    | Above 70   |
| Medium   | 15-70  |
| Small    | Below 15   |

16 Central Pollution Control Board, 2004

Waste materials produced in these establishments are of three types: solid, liquid, and gas. Solid waste is generated from manure, intestinal contents, hair, horns, hooves, gallbladders, trimmings, internal organs, condemned carcasses or body parts, carton, and plastics. Solid wastes from slaughterhouses are varied depending on the kind and scale of operations. Liquid wastes of slaughterhouses come from urine, blood, and wastewater from the slaughter processes. Odours and emissions are also produced in the operations.

These waste materials if not handled and managed properly pose a hazard to the environment. High concentration of animal blood and fat, dirt, and other pollutants in slaughterhouse effluent renders it very toxic to the receiving water bodies.

Usually the quantity of wastes per animal is large in small scale operations, where the recovery of offal is ineffective. Its main products are fresh meat in the form of whole, half, or quarter carcasses, or in smaller meat cuts. By-product processing is usually absent. In modern slaughterhouses, there is extensive processing of by-products. In such plants at least three additional operations are conducted: (i) rendering, paunch, and viscera handling; (ii) blood processing; and (iii) hide and hair processing. By these operations, maximum recovery of edible and inedible materials from the offal is achieved, and this results in lower production of wastes per animal.

### 7.6.1 PROCESSING SLAUGHTERHOUSE WASTE

The solid waste of slaughterhouses can be broadly classified into two categories: (i) vegetative matter (type I) such as rumen, stomach and intestine contents, dung, agriculture residues, etc., and (ii) animal matter (type II) like inedible offals, tissues, meat trimmings, waste and condemned meat, bones, etc. These waste streams can be segregated and treated separately.



For large and medium slaughterhouses, biomethanation of type-I waste and rendering for type-II waste are suggested. Biomethanation requires less space, which is advantageous for the slaughterhouses with land constraints. In-vessel high rate composting of type I waste may also be considered, but these systems are quite expensive.

In small slaughterhouses, sophisticated and capital-intensive technologies are unviable due to low volume of wastes and non-availability of other infrastructure facilities. For small slaughterhouses, a viable approach would be biomethanation or deep burial facility provided by the municipal authority.

The best practicable methods currently available for processing and disposal of different wastes from slaughterhouses are detailed in Table 7.4.

For large and medium slaughterhouses, biomethanation of type-I waste and rendering for type-II waste are suggested

For small slaughterhouses, biomethanation or deep burial facility is suggested



**Table 7.4: Methods for Processing, Utilisation and Disposal of Solid Wastes from Slaughterhouse<sup>17</sup>**

| WASTE   | CONSTITUENTS OF WASTES   | SH CATEGORY | METHOD(S)   |
|---------|--|-------------|---|
| Type I  | Vegetable matter such as rumen, stomach and intestinal contents, dung, agriculture residues, etc.    | Large       | Biomethanation or in-vessel composting              |
|         |  | Medium      | Biomethanation or in-vessel composting              |
|         |  | Small       | Biomethanation or pooling to a centralised facility |
| Type II | Animal matter such as inedible offal, tissues, meat trimmings, waste and condemned meat, bones, etc. | Large       | Rendering or CPU                                    |
|         |  | Medium      | Rendering or CPU                                    |
|         |  | Small       | Deep burial facility provided by municipality       |

**Composting:** Composting is an aerobic biological decomposition of organic material, resulting in a stable humus-like product. This is a common practice of waste stabilisation but requires proper understanding of the method (for more details, refer to Section 3.2 of Part II).

Both type I and type II slaughterhouse wastes can be stabilised through composting. The compost stack is prepared by adding alternate layers of type I waste and type II waste, to build a 4 to 5 feet high heap. The heap should be laid directly on the ground. It is advisable to put a layer of about 6 -inches of coarse material underneath, such as maize or millet stalks, banana stumps, straw, grass, small twigs, etc., to achieve proper ventilation.

Large- sized matter (organs such as kidneys and lungs, or other similar wastes) in type II wastes should be minced to 2 to 3-inch pieces before composting. For better results, it is advised to mix these pieces with earth and evenly spread out in the centre of the heap where the temperature is high.

The ruminal and intestinal contents provide sufficient moisture for initiating and sustaining bacterial activity. As such, under normal circumstances, no additional water is required.

**Biomethanation:** Slaughterhouse waste is anaerobically stabilised in biomethanation. The success of the process, especially the effective removal of biochemical oxygen demand (BOD), has led to the acceptance of biogas plants for processing slaughterhouse wastes.

<sup>17</sup> Sanitation in Slaughter House, CPCB (2004). Available at: <http://www.cpcb.nic.in/divisionsofheadoffice/pci3/pci3divslaughter.pdf>.

**High Rate Biomethanation:** The essential elements of a high rate biomethanation process are: size reduction and slurry making, operation at thermophilic temperature range, and complete mixing to achieve a uniform temperature with more or less uniform feeding of the waste. Pre-thickening or dilution of the digester contents are optional features of a high rate digestion system. The benefits of high rate biomethanation are reduced digester volume and increased pathogen kill. Wastes consisting of rumen and paunch contents, dung, agriculture residue, fat, and blood may be processed in the high rate biomethanation plant.

**Rendering:** Rendering plants are set up for the recovery of fats and bone and meat meal. This is a useful method for the recovery of by-products from slaughterhouse waste.

All animal matter such as inedible offal, tissues, meat trimmings, waste and condemned meat, bones, etc. can be processed in a rendering system, since the main constituents of animal matter are fat, water, and solids. Rendering is effected by heating; heat ruptures the connective tissue of individual fat and muscle cells so that raw fat and other material bound within is released. Wet and dry rendering plants may be adopted. Wet rendering plants yield animal fat and bone meal. Dry rendering enables 20% higher yield than wet rendering.<sup>18</sup>

Fat recovered during rendering is used for industrial purposes, and making soap and greases. Fat recovered from flesh of healthy parts can be edible. Meat meal or bone meal is utilised for the manufacture of stock feed and fertilizers. Sludge bio-solids from dry rendering plants should be appropriately treated and disposed.

Incineration is also an option for the treatment of slaughterhouse waste.



**Clean Technology and Modernisation for Slaughterhouse Waste Treatment: Initiative of Municipal Corporation of Delhi in Ghazipur**

**Location:** Ghazipur, New Delhi

**Year of Start:** 2009

**Main Players:** Erstwhile Municipal Corporation of Delhi (MCD), East Delhi Municipal Corporation (EDMC), Haarslev Industries, Frigorifico Ala Anna Pvt Ltd.

**Approach:** The oldest slaughterhouse in Idgah, Delhi posed a major public health and environmental hazard due to indiscriminate disposal of waste, inadequate water supply, and discharge of effluents in open drains. Concerns raised by local residents, non-government organisations (NGOs) and MCD prompted the Supreme Court, in 2004, to direct the MCD

18 Sanitation in Slaughter House, CPCB (2004). Available at: <http://www.cpcb.nic.in/divisionsofheadoffice/pci3/pci3iiiivslaughter.pdf>.

to relocate the Idgah slaughterhouse to a modernised slaughterhouse in Ghazipur. This led to the establishment of a modernised facility spread across 30 acres of land having slaughterhouse, livestock markets, rendering plant, roads, etc. and an effluent treatment plant (ETP) to ensure wastewater treatment and processing of waste as per the standards prescribed by Central Pollution Control Board (CPCB). The slaughterhouse plant has been established as a turnkey project. The funding for the project was from National Capital Region Planning Board (Rs. 60 crore loan), Ministry of Urban Development (Rs. 20 crore grant + Rs. 20 crore loan), Government of National Capital Territory of Delhi (Rs. 70 crore loan), and Ministry of Food Processing Industries (Rs 4 crore grant). The plant operation and maintenance has been handed over to the private operator named Frigorifico Allana, on annual royalty in 2009 for 10 years. The approach that was adopted for installation and operationalisation of the slaughterhouse plant is detailed below.

#### **Institutional:**

- Head of Veterinary Department of erstwhile MCD (now EDMC) and project in-charge of the private operator work closely and coordinate on a daily basis for smooth execution and functioning of the plant.
- Adequate health and safety measures (uniforms, gumboots, gloves, masks), as well as intensive trainings on regular basis, were provided to the workers to maintain cleanliness and hygiene during operation.
- Intensive trainings and capacity building on regular basis were provided to the workers for them to operate the rendering plant.

#### **Managerial:**

- The plant operates in three shifts. The morning and evening shifts are reserved for general traders and the middle shift for the operator of the facility.
- Token systems for the general traders were introduced to maintain transparency and discipline during peak shifts.

#### **Stakeholder Consultations:**

- Intensive meetings of MCD officials with the slaughterhouse association convinced the association about the necessity and urgency of the relocation.

#### **Outcomes:**

- Livestock market in Ghazipur is about 3–4 times larger than Idgah facility, thereby reducing the chances of insanitation and overcrowding. An ETP of 1,750 kiloliters per day capacity to treat the liquid waste and a rendering plant of 20 tonnes capacity including ETP of 250 kiloliters per day capacity have been established.
- Three separate lairages with adequate water, shed, and fodder facilities have been constructed to allow proper rest to the animals before slaughtering, facilitating proper examination of each animal by the veterinary department.
- The entire process in the slaughterhouse is carried out under hygienic conditions, and effluents discharged are treated and disposed of safely.

- Utilisation of the by-products obtained after the rendering process for industrial use.
- Capacity of slaughtering 5,500 animals per day (1,500 buffaloes and 4,500 sheep and goats).
- Treatment capacity of 60 tonnes of paunch waste in the plant.
- Carcasses were taken back by the shopkeeper to their shop for retail distribution.
- There was gradual acceptance of the general shopkeepers and traders for centralised and modern slaughterhouse facility, as it provided them a better market price owing to the quality of the slaughtered product.

**Success Factor:**

- Intensive training was provided to the workers to handle the waste scientifically.
- Modern and sophisticated technology was used for slaughtering.

**Overall Sustainability:**

The total cost of the plant was Rs. 183 crore. The cost comprises the construction and installation of the plant as well as the procurement of machinery for the rendering plant. The operational agreement is such that the concessionaire has to pay erstwhile MCD (now EDMC) Rs. 1.5 crore quarterly as a royalty for the plant. In order to sustain and optimised operation of the plant, the concessionaire, in consultation with erstwhile MCD, has introduced user charges against general traders at Rs. 45 for sheep and goats and Rs. 300 for buffalo. The concessionaire has been given the liberty to run one shift for their own export. Apart from this, the by-products (bone meal, oils) obtained from the rendering plant act as value-added material for the concessionaire.

*Source: East Delhi Municipal Corporation*

## 7.7 ELECTRIC AND ELECTRONIC WASTE

E-waste means any waste from electrical or electronic equipment, whole or in parts, or rejects from their manufacturing and repair processes, which are intended to be discarded.

### 7.7.1 E-WASTE MANAGEMENT RULES, 2016



E-waste is regulated under the E-Waste Management Rules, 2016.

According to Schedule IV of the E-Waste Management Rules, 2016, the responsibilities of the Urban Local Bodies are:

- To ensure that e-waste if found to be mixed with MSW is properly segregated, collected and is channelised to either authorised dismantler or recycler.

- To ensure that e-waste pertaining to orphan products is collected and channelised to either an authorised dismantler or recycler.

Municipal authorities must therefore give basic education to their staff on identification of e-waste and on measures to be taken when they find such a waste mixed with municipal solid waste.

These rules are based largely on the principle of Extended Producer Responsibility (EPR), which assigns the producer with the responsibility of ‘end-of-life’ management of the electrical and electronic equipment (for details refer to Section 2.1.2 of Part II). The objective of the rules is to put in place an effective mechanism to regulate the generation, collection, storage, transportation, environmentally sound recycling, treatment and disposal of the e-waste. It is mandatory that e-wastes be managed in accordance with provisions under these rules.

As per E-Waste Management Rules, 2016, the ULB should channelise e-waste found mixed with MSW to authorised e-waste recyclers



Bruhat Bengaluru Mahanagara Palike (BBMP) is adopting a three-bin system for collection of wet, dry, and e-waste. More than 10 collection bins for e-waste disposed of by citizens have been set up in the city. Citizens are required to bring e-waste to these locations. E-waste collected from these bins is recycled by authorised recyclers in an environmentally sustainable manner.

### 7.7.2 CURRENT STATUS OF E-WASTE GENERATION AND ITS MANAGEMENT

Electronic waste is one of the fastest growing waste streams in the country with a growth rate of 10% per annum. An increase in the use of electrical and electronic products and their high rate of obsolescence leads to generation of huge amounts of electrical and electronic waste (e-waste). As per preliminary estimates of the Central Pollution Control Board (CPCB), e-waste generation in India was 0.8 million tonnes in 2012.

E-waste management practices in India are beset with numerous shortfalls, such as the difficulty in maintaining an inventory of generated e-waste, unhealthy conditions of informal recycling, inadequate capacities, and lack of awareness among generators and ULBs.

### 7.7.3 E-WASTE CATEGORIES

E-waste is classified into two categories according to their characteristics under Schedule I of E-Waste Management Rules, 2016 (Table 7.5).

**Table 7.5: Categories of electronic wastes as per E- Waste Management Rules, 2016<sup>19</sup>**

| WASTE CATEGORY | WASTE STREAM   | TYPE OF E-WASTE  |
|----------------|--|--|
| Category I     | Information technology and telecommunication equipment | Centralised data processing: Mainframes, Minicomputers; Personal Computing: Personal Computers (Central Processing Unit with input and output devices); Personal Computing: Laptop Computers (Central Processing Unit with input and output devices); Personal Computing: Notebook Computers, Notepad Computers; Printers including cartridges; Copying equipment; Electrical and electronic typewriters; User terminals and systems; Facsimile; Telex; Telephones; Pay telephones; Cordless telephones; Cellular telephones and Answering systems |
| Category II    | Consumer electrical and electronics                    | Television sets (including sets based on (Liquid Crystal Display and Light Emitting Diode technology); Refrigerator; Washing Machine; Air-conditioners excluding centralised air conditioning plants; Fluorescent and other mercury containing lamps.  |

E-waste consists of more than 1000 different components which can be categorised as “hazardous” and “non-hazardous”. Typically, e-waste consists of:<sup>20</sup>

- ferrous metals (approximately 50%);
- plastics (approximately 21%);
- non-ferrous metals like copper, aluminium, silver, gold, platinum, palladium etc. (approximately 13%); and
- other components like glass etc. (approximately 16%).

Most plastic components in e-waste include phthalate plasticiser and brominated flame retardants, which are hazardous. Therefore, even though the plastic recovery potential from e-waste can be quantified, presence of above mentioned chemicals limits the actual recycling potential.

<sup>19</sup> E-Waste Management Rules, 2016

<sup>20</sup> Converting Waste Plastics Into a Resource, United Nations Environment Programme (2009). Available at: [http://www.unep.or.jp/letc/Publications/spc/WastePlasticsEST\\_AssessmentGuidelines.pdf](http://www.unep.or.jp/letc/Publications/spc/WastePlasticsEST_AssessmentGuidelines.pdf)







**The following three E-Waste streams are not covered under the Schedule I of the E-Waste Management Rules, 2016:**

- Batteries used in electrical and electronic equipment, such as Ni-Cd, Li-ion, Mercury etc.
- Dry cell batteries

It is very likely that these components are found in municipal solid waste (MSW) despite their inherent recycling potential (since no vendor pays for them). Local authorities (like Ahmedabad Municipal Corporation) has started an initiative of collecting these wastes separately or as part of the special waste stream or mixed with dry waste (where special waste is not collected separately). This special waste is disposed appropriately in a separate designated portion of the sanitary landfill.



**Compact Fluorescent Lamps Recycling**

There are two methods of recycling compact fluorescent lamps (CFLs): shredder method and end cut method. The shredder method involves crushing of CFLs and chemical treatment of the crushed material in dust-tight containers to avoid spillage of any harmful substances. The hazardous mercury and phosphor are removed by specialised processes, and the remaining material is sorted into glass, metals, and plastics. The end cut method involves removing of ends from the lamps. Ends of lamps consist of metal and plastic which further get segregated; the tube is chemically treated to recover mercury and phosphor. Phosphor powder and mercury can be used in new lamps or other industrial purposes, while glass can be processed further in the furnace for reuse. The aluminium end caps are sent for smelting and other metals are recycled. However, it should be noted that such recycling facilities are not yet commonly established in the country and establishment of such facilities should be encouraged by all state governments.

## 7.8 WASTE TYRES

The management of used tyres is a challenge for even the most modern MSWM systems, due to the physical properties and shape of tyres. Tyres are composed primarily of complex natural and synthetic rubber compounds, both of which have substantial heating value and various other materials.



The Government of Maharashtra has issued Draft Guidelines for Regulation of Tyre Retreading, Tyre Pyrolysis (Recycling) and Prohibition on Burning of Tyres (2014). The notification lays emphasis on life cycle approach while recycling tyres. It provides guidance for the approach to be adopted for tyre retreading, location of pyrolysis units, pollution control measures, safety arrangements and environmental compliances to be achieved by such units.

*Source: Draft Guidelines for Regulation of Tyre Retreading Activities in the State of Maharashtra, Notification-Environment Department, Government of Maharashtra*

### 7.8.1 STORAGE OF USED TYRES

Stockpiles of used tyres can create substantial land use problems, and serve as breeding grounds for insects and other small animals that harbour pathogens detrimental to human health and environment. Stockpiles can self-ignite; and when it does, the fire may be difficult to control, leading to negative human health and environmental impacts.

### 7.8.2 REUSE OF USED TYRES

Some of the more common reuse practices include the following:

- Reuse is done through retreading for extended service.
- Used tyres are utilised for building retaining walls for narrow hill roads, for controlling erosion along drainage channels, as barriers in coastal areas, as crash barriers, for earth filling in civil engineering works, etc. They are also used during landfill construction for weighing down the liner material.
- Cuttings from used tyres are used in shoe soles, gaskets, continuous conveyor belts, etc. They may also be used for low-grade products such as automobile floor mats, and rubber wheel handcarts and wheel barrows.

### 7.8.3 PROCESSING OF USED TYRES

The typical product yield from scrap tyres is tabulated in Table 7.6:

Table 7.6: Typical Product Yield from Scrap Tyres<sup>21</sup>

| PRODUCT YIELD FROM SCRAP TYRES | TRUCK TYRES | EQUIPMENT MANUFACTURER (EM) TYRES | CAR TYRES |
|--------------------------------|-------------|-----------------------------------|-----------|
| Crumb rubber                   | 70%         | 78%                               | 70%       |
| Steel                          | 27%         | 15%                               | 15%       |
| Fiber and scrap                | 3%          | 7%                                | 15%       |

The recovery of rubber from used tyres can be very energy-intensive, and such processing may generate hazardous substances and many other types of process residues. Processing of tyre materials should be conducted under controlled conditions, as it generates dust and buffing, which may be carcinogenic to workers. Pulling out the steel wires followed by shredding are the main processes.

### 7.8.4 CO-PROCESSING OF WASTE TYRES

Co-processing of tyres as fuel in cement plants is approved as an environmentally safe and efficient method to dispose of used tyres.

21 Scrap Tire Recycling, Reschner, K (2008). Available at: [http://entire-engineering.de/Scrap\\_Tire\\_Recycling.pdf](http://entire-engineering.de/Scrap_Tire_Recycling.pdf)



Co-processing with tyres is also known to improve the combustion characteristics of high ash coal.

The CPCB guidelines on co-processing in cement, power, or steel industry indicate specific requirements for the feeding of materials for co-processing, suitability of substances for co-processing, operating conditions for co-processing plants, air pollution control requirements, and emission standards.

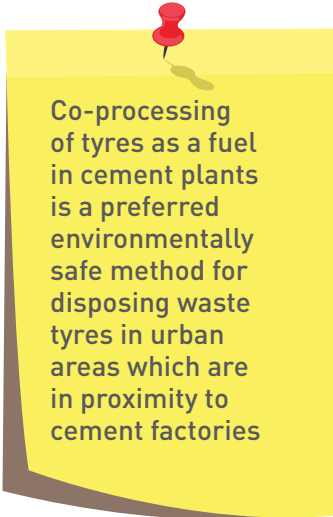

Co-processing of tyres as a fuel in cement plants is a preferred environmentally safe method for disposing waste tyres in urban areas which are in proximity to cement factories

## 7.9 LEAD BATTERY WASTE

Once the lead acid battery is no longer capable of being recharged or cannot retain its charge, it is a waste and should be disposed. At the end of its life, the battery is classified as a hazardous waste and should be handled as prescribed in the Batteries (Management & Handling [M&H]) Rules, 2001 to prevent damage to human health and environment.

### 7.9.1 THE BATTERIES (MANAGEMENT & HANDLING) RULES, 2001

The Batteries (M&H) Rules, 2001 govern the management of lead acid batteries, which are a source of electrical energy and contain lead metal. Used lead acid batteries are not considered a part of MSW and should not be mixed while disposal.

These rules apply to every manufacturer, importer, re-conditioner, assembler, dealer, recycler, auctioneer, consumer, and bulk consumer involved in the manufacture, processing, sale, purchase, and use of batteries or components thereof.



#### Clause 7: Responsibilities of dealer:

“It shall be the responsibility of the dealer to:

- ensure that the used batteries are collected back as per the Schedule against new batteries sold;
- ensure safe transportation of collected batteries to the designated collection centres or to the registered recyclers; and
- ensure that no damage is caused to the environment during storage and transportation of used batteries.”



#### Clause 10: Responsibilities of consumer or bulk consumer:

“It shall be the responsibility of the consumer to ensure that the used batteries are not disposed of in any manner other than depositing with the dealer, manufacturer, importer, assembler, registered recycler, re-conditioner or at the designated collection centres.

It shall be the responsibility of the bulk consumer to:

1. ensure that the used batteries are not disposed of in any manner other than by depositing with the dealer or manufacturer or registered recycler or importer or reconditioner or at the designated collection centres”



**Clause 11: Responsibilities of auctioneer:**

“The auctioneer shall ensure that used batteries are auctioned to the registered recyclers only.”

Municipal authorities should acquaint their SWM staff with the above provisions. When disposed lead acid batteries are found mixed with MSW, ULB staff should be trained to report the identified defaulters to the concerned authority for taking appropriate action.

## **7.10 ACTION POINTS FOR AWARENESS GENERATION THROUGH INFORMATION, EDUCATION, AND COMMUNICATION ACTIVITIES FOR SPECIAL WASTE INCLUDING DOMESTIC HAZARDOUS WASTE**

- Provide information to the community on different types of special wastes including domestic hazardous waste and their related impacts on human life and environment.
- Generate awareness in the community about segregating special waste at household level to prevent its mixing with MSW. Equally important is to provide information on collection and disposal systems for special waste and related initiatives taken up by the ULB.
- Encourage usage of sustainable material such as jute or cloth bags, energy efficient lighting and electronic appliances, and multi-use consumables as an effective strategy to minimise special waste generation.
- Provide and communicate incentives to the community for making use of dry waste and domestic hazardous waste collection centres.
- Inform public about economic and environmental benefits of reducing, reusing, and recycling special waste.
- Engage with local businesses or electronic suppliers and create awareness on EPR initiatives around special waste. Promote incentives to encourage such initiatives.
- Educate public about prevalent EPR initiatives.

# Glossary



|                                    |  |
|------------------------------------|--|
| <b>Acid gas</b>                    | Gases produced during the combustion process containing significant quantities of acidic components such as sulphides and chlorides.   |
| <b>Active gas collection</b>       | A technique that forcibly removes gas from a landfill by attaching a vacuum or pump to a network of pipelines in the landfill or surrounding soils to remove the gases.  |
| <b>Aerated static pile</b>         | The process of exposing bulk material, like compost, to air. Forced aeration refers to the use of blowers in compost piles.  |
| <b>Aeration</b>                    | The process by which air is circulated through, mixed with or dissolved water for exposing bulk material, like compost.  |
| <b>Aerobic</b>                     | A system / material where free oxygen is available so that aerobic reactions can take place.   |
| <b>Aerobic composting</b>          | A controlled process involving microbial decomposition of organic matter in the presence of oxygen.  |
| <b>Agricultural waste</b>          | Waste material generated from agricultural activity or agro industry residues, e.g., straw, husk, tree pruning etc.  |
| <b>Air classifier</b>              | A device used to separate materials by a combination of size, shape and density at a facility( such as a MRF). It is the column of rising air with an upward force act on the mixed material to be sorted. The mixed materials with differing physical characteristics can be separated quickly and efficiently. |
| <b>Air Density Separator (ADS)</b> | A device to separate sand, grit and other heavy particles from compost, by using floatation from a fluid bed condition. Compost is sucked up and heavy particles fall behind.  |
| <b>Anaerobic digestion</b>         | A controlled process involving microbial decomposition of organic matter in absence of oxygen.   |
| <b>Animal house</b>                | A place where animals are reared/kept for the purpose of experimenting or texting.   |
| <b>Aquifer</b>                     | Aquifers are underground layers of rock that are saturated with water that can be brought to the surface through natural springs or by pumping.  |
| <b>Ash</b>                         | The non-combustible, solid by-product of incineration or other combustion process.   |

|                          |   |
|--------------------------|---|
| <b>Ash residues</b>      | The left-over material from a combustion process. They may take the form of fly ash or bottom ash.  |
| <b>Assembler</b>         | A person who manufactures lead acid batteries by assembling various components.   |
| <b>Attenuation</b>       | A process of converting and destroying a chemical compound as it passes through layers of soil or rock.   |
| <b>Auction</b>           | Bulk sale of used lead acid batteries or component (s) thereof by invitation of tenders or auction, contract or negotiation by individual(s), companies or Government Departments.  |
| <b>Auctioneer</b>        | A person(s) who auctions used lead acid batteries or components, thereof.   |
| <b>Authorisation</b>     | The permission given by the State Pollution Control Board or Pollution Control Committee as the case may be, to the “operator of a facility” or “urban local body”, or any other agency responsible for processing and disposal of solid waste.   |
| <b>Authorised person</b> | An occupier or operator authorised by the prescribed authority to generate, collect, receive, store, transport, treat, dispose or handle bio-medical waste in accordance with these rules and guidelines issued by the Central Pollution Control Board, Ministry of Environment, Forest and Climate Change, Ministry of Health and Family Welfare, Government of India. |
| <b>Autoclaving</b>       | Sterilisation via a pressurised, high-temperature steam process.  |
| <b>Bag house</b>         | A combustion plant emission control device that consists of an array of fabric filters through which flue gases pass in an incinerator flue. Particles are trapped and thus prevented from passing into the atmosphere.   |
| <b>Bailing</b>           | A machine used to compress recyclables into bundles to reduce volume. Balers are often used for newspaper, plastics, and corrugated cardboard.  |
| <b>Battery</b>           | A battery is a device consisting of one or more electrochemical cells that convert stored chemical energy into electrical energy.   |



|  |  |
|--|--|
| <b>Bentonite</b>   | A type of soil that swells greatly in the presence of water. Since bentonite impedes the flow of water, it is used for liners, covers, and various other landfill applications.  |
| <b>Berm</b>  | An elongated pile of soil used to control and direct the flow of surface water runoff. Berms may also be used to block out noise and screen operations from public view.   |
| <b>Bio-degradable substances</b>                         | Any organic material that can be degraded by micro-organisms into simpler stable compounds.  |
| <b>Biologicals</b>                                       | Any preparation made from organisms and micro-organisms or product of metabolism and biochemical reactions intended for the use in diagnosis, immunisation, or the treatment of human beings or animals, or in research activities pertaining thereto. |
| <b>Bio-medical waste</b>                                 | Any waste, which is generated during the diagnosis, immunisation, treatment of human beings or animals, or in research activities pertaining thereto or in the production or testing of biologicals including the categories.                          |
| <b>Bio-medical waste treatment and disposal facility</b> | Any facility wherein treatment, disposal of bio-medical waste or processes incidental to such treatment and or disposal is carried out and includes common treatment facilities.   |
| <b>Biomethanation</b>                                    | A process which entails enzymatic decomposition of the organic matter by microbial action to produce methane rich biogas.  |
| <b>Bottle bill</b>                                       | A law requiring deposits on beverage containers.   |
| <b>Bottom ash</b>  | Bottom ash is primarily a toxic residue of incineration made from agglomerated ash particles that are too large to be carried in the flue gases and fall through open grates to an ash hopper at the bottom of the furnace.                            |
| <b>Buffer zone</b>                                       | A zone of no-development which shall be maintained around landfills, processing and disposal facilities of solid waste demarcated.   |
| <b>Bulking agent</b>                                     | A material used to add volume to another material to make the second material more porous, which increases air flow. For example, municipal solid waste may act as a bulking agent when mixed with water treatment sludge.                             |

|  |   |
|--|---|
| <b>Bulky waste</b>                     | Large wastes (such as appliances, furniture, trees and branches, etc.) that cannot be handled by normal MSW processing methods.   |
| <b>Buy back centre</b>                 | A facility to which individuals bring recyclables in exchange for payment.  |
| <b>Capacity building</b>               | Enabling people, organisations, and societies to develop, strengthen, and expand their abilities to meet their goals or fulfill their mandates is referred to as capacity building. It is a long-term and continuous process that focuses on developing human resources, organisational strength, technology know-how etc involving all stakeholders and is strengthened through the transfer of knowledge and skills that enhance individual and collective abilities to deliver services and carry out programs that address challenges in a sustainable way. |
| <b>Cell</b>                            | The basic unit by which a landfill is developed. It is the general area where incoming waste is tipped, spread, compacted, and covered.   |
| <b>Central Pollution Control Board</b> | The Central Pollution Control Board constituted under sub-section (1) of Section 3 of the Water (Prevention and Control of Pollution) Act, 1974 (6 of 1974).  |
| <b>Cleaner production</b>              | Processes designed to reduce the wastes generated by production.  |
| <b>Co-disposal</b>                     | The disposal of different types of waste together in one area of a landfill or dump. For instance, sewage sludge may be disposed of with regular solid wastes.  |
| <b>Cogeneration</b>                    | Production of both electricity and steam from one facility, from the same fuel source.  |
| <b>Collection</b>                      | Lifting and removal of municipal solid waste from collection points or any other location.  |
| <b>Collection centre</b>               | A centre established, independently or jointly or a registered society, or a designated agency, or a company or an association to collect e-waste.  |
| <b>Combustibles</b>                    | Inflammable materials in the waste stream, including paper, plastics, wood, food and garden wastes.   |

|  |  |
|--|--|
| <b>Combustion</b>                        | Combustion is a chemical process in which a substance reacts rapidly with oxygen and gives off heat. In MSWM, the combustion process is carried out in an incinerator. |
| <b>Combustion Facility</b>               | Any unit and/or equipment dedicated to the thermal or oxidation treatment of municipal solid waste with or without recovery of heat generated.                         |
| <b>Commercial waste</b>                  | Waste materials originating in wholesale, retail, institutional, or service establishments, such as office buildings, stores, markets, theatres, hotels and warehouse. |
| <b>Commingled</b>                        | Mixed recyclables that are collected together after having been separated from mixed MSW.  |
| <b>Communication</b>                     | An exchange or flow of information or ideas across the people through not as learners but as a target audience.  |
| <b>Compactor vehicle</b>                 | A collection vehicle using high-power mechanical or hydraulic equipment to reduce the volume of solid waste.   |
| <b>Composite liner</b>                   | A liner system for a landfill consisting of an engineered soil layer and a synthetic sheet of material.  |
| <b>Compost</b>                           | The material resulting from decomposition of organic matter also called humus it act as is a soil conditioner.   |
| <b>Compost pad / platform</b>            | Hard impermeable surface, preferably concrete, on which composting is done.  |
| <b>Composting</b>                        | A controlled process involving microbial decomposition of organic matter.  |
| <b>Construction</b>                      | The process of erecting of buildings or built facility or other structure, or building of infrastructure including alteration in this entities.                        |
| <b>Construction and demolition waste</b> | The waste comprising of building materials debris and rubble resulting from construction, re-modelling, repair and demolition of any civil structure.                  |
| <b>Consumer</b>                          | Any person using electrical and electronic equipment excluding the bulk consumers.   |
| <b>Contractors</b>                       | A person or firm that undertakes a contract to provide materials or labour to perform a service or do a job for service providing authority.                           |

|                             |   |
|-----------------------------|---|
| <b>Controlled dump</b>      | A planned landfill that incorporates, to some extent, some of the features of a sanitary landfill: siting with respect to hydro-geological suitability, grading, compaction in some cases, leachate control, partial gas management, regular (not usually daily) cover, access control, basic recordkeeping, and controlled scavenging.   |
| <b>Conveyor belt</b>        | A wide belt made of rubber, textile, nylon or more commonly composite material, which moves on wide rollers. In compost industry chain drive is popular as the belt moves in a guided manner, directed by the chain sprockets. Conveyor belts are used for material movement in different stages.   |
| <b>Co-processing</b>        | Co-processing is a secure form of waste management that fully recovers the energy and mineral content from waste for beneficial re-use as fuel for energy generation and product additives for manufacturing. Use of solid waste as raw material(plastics, tyres etc or as a source of energy or both to replace or supplement the natural mineral resources) and fossil fuels in industrial processes. |
| <b>Cover material</b>       | Material, either natural soil or geosynthetic material, used in a landfill to impede water infiltration, landfill gas emissions, and bird and rodent congregation. It is also used to control odors and make the site more visually attractive. Landfills have three forms of cover: daily cover, intermediate cover, and final cover.  |
| <b>Curing</b>               | Allowing partially composted materials to reside in a pile for a specified period of time as part of the maturing process in composting.  |
| <b>Daily cell</b>           | In landfills, a portion of refuse that has been compacted and then surrounded with cover material. Daily cover is placed over the landfilled materials at the end of each day to complete the cell.   |
| <b>Daily cover material</b> | Material, usually soil that is used in a landfill to cover the refuse after it has been compacted at the end of each day. The cover is placed mainly to ward off animals and for odor control.  |
| <b>Dealer</b>               | A person who sells and receives lead acid batteries or components thereof to and from the consumers or other dealers or retailers on behalf of the manufacturers, importers, assemblers and reconditioners or otherwise.  |

|                                     |   |
|-------------------------------------|---|
| <b>De-Construction</b>              | A planned selective demolition in which salvage, re-use and recycling of the demolished structure is maximised.   |
| <b>Demolition</b>                   | Breaking down or tearing down buildings and other structures either manually or using mechanical force (by various equipment) or by implosion using explosives.   |
| <b>Designated collection centre</b> | A collection centre established, individually or jointly by one or more manufacturers or importers, assemblers and re-conditioners in pursuance of their responsibilities under rule – 4 of these rules.  |
| <b>Detention basin</b>              | An excavated area of land that is used to collect surface water runoff for the purpose of creating a constant outflow from the basin.   |
| <b>Detinning</b>                    | Recovering tin from “tin” cans by a chemical process that makes the remaining steel more easily recycled.   |
| <b>Dismantler</b>                   | Any person, or registered society, or designated agency, or a company or an organisation engaged with dismantling the used electrical and electronic equipments into their components.  |
| <b>Disposal</b>                     | The final and safe disposal of solid waste on as specified in schedule I to prevent contamination of ground-water, surface water, ambient air and attraction of animals and birds.  |
| <b>Domestic hazardous waste</b>     | Domestic hazardous wastes means waste contaminated with hazardous chemicals or infectious waste such as discarded paint drums, pesticide cans, CFL bulbs, tube lights, expired medicines, broken mercury thermometers, used batteries, used needles, gauge and syringes, etc. generated at the household level. |
| <b>Drop-off centre</b>              | An area or facility for receiving compostable or recyclables that are dropped off by waste generators.  |
| <b>Drop-off collection</b>          | A method of collecting recyclable or compostable materials in which the materials are taken by individuals to collection sites, where they deposit the materials into designated containers.  |
| <b>Dry waste</b>                    | Waste other than food waste and inert and includes recyclable waste, non-recyclable waste, combustible waste and sanitary waste.  |

|  |   |
|--|---|
| <b>Dump sites</b>  | A land utilised by urban local body for unscientific disposal of municipal solid waste without following the principles of sanitary landfilling.  |
| <b>E-waste</b>   | Means electrical and electronic equipment, whole or in part or rejects from their manufacturing and repair process, which are intended to be discarded as waste.  |
| <b>Electrical and electronic equipment</b>                 | Means equipment which are dependent on electrical currents or electro-magnetic fields to be fully functional.   |
| <b>Electrostatic precipitator</b>                          | Device for removing particulate matter from an incinerator facility's air emissions. It works by causing the particles to become electrostatically charged and then attracting them to an oppositely charged plate, where they are precipitated out of the flue gasses. |
| <b>Emissions</b>   | Gases released into the atmosphere.   |
| <b>End use market</b>                                      | A company that purchases recycled materials for use as feedstock in manufacturing new products.   |
| <b>Energy recovery</b>                                     | The process of extracting useful energy from waste, typically from the heat produced by incineration or via methane gas from landfills.   |
| <b>Environmental Impact Assessment (EIA)</b>               | An evaluation designed to identify and predict the impact of an action or a project on the environment, human health and well-being. It can include risk assessment as a component, along with economic and land use assessment.  |
| <b>Environmental technologies</b>                          | Means any technology approved by the Central Government from time to time.  |
| <b>Environmentally sound management of E-waste</b>         | Means taking all steps required to ensure that e-waste are managed in a manner which shall protect health and environment, against any adverse effects, which may result from hazardous substances contained in such wastes.  |
| <b>Environmentally sound management of hazardous waste</b> | Means taking all steps required to ensure that the hazardous waste are managed in a manner which shall protect health and the environment against the adverse effects which may result from such waste.   |

|   |  |
|---|--|
| <b>Extended Producer Responsibility (EPR)</b> | Means responsibility of any producer of electrical and electronic equipment, for their products beyond manufacturing until environmentally sound management of their end-of-life products.   |
| <b>Export</b>                                 | With its grammatical variations and cognatic expressions, means taking out of India to a place outside India.  |
| <b>Exporter</b>                               | Means any person under the jurisdiction of the exporting country who exports hazardous waste including the country, which exports hazardous waste.   |
| <b>Facility</b>                               | Any establishment wherein the solid waste management processes namely segregation, recovery, storage, collection, recycling, processing, treatment or safe disposal are carried out.   |
| <b>Ferrous metals</b>                         | Metals derived from iron. They can be removed from commingled materials using large magnets at separation facilities.  |
| <b>Flaring</b>                                | The burning of landfill gas/methane captured and emitted from collection pipes at a landfill.  |
| <b>Flood plain</b>                            | A region of land around a body of water, usually a river or stream, that is flooded on a regular basis, usually annually.  |
| <b>Flue gas</b>                               | All gasses and products of combustion that leave a furnace by way of a flue or duct.   |
| <b>Fluidised-bed incinerator</b>              | A type of incinerator in which the stoker grate is replaced by a bed of limestone or sand that can withstand high temperatures. The heating of the bed and the high air velocities used, causes the bed to bubble, which gives rise to the term “fluidised”. |
| <b>Fly ash</b>                                | A highly toxic particulate matter captured from the flue gas of an incinerator by the air pollution control system.  |
| <b>Food stuff</b>                             | Means ready to eat food products, fast foods, processed or cooked food in liquid, powder, solid or semi-solid form.  |
| <b>Garbage</b>                                | It is the common term used for unwanted or discarded material which is not used anymore, is called refuse or garbage.  |

|  |   |
|--|---|
| <b>Gas control and recovery system</b>     | A series of vertical wells or horizontal trenches containing permeable materials and perforated piping. The systems are designed to collect landfill gases for treatment or for use as an energy source.                                  |
| <b>Gas monitoring probe</b>                | Probes placed in the soil surrounding a landfill above the groundwater table. The probes are used to determine if landfill gases are migrating away from the landfill.  |
| <b>Generation rate</b>                     | The amount of waste that is produced over a given amount of time. For example, a district may have a generation rate of 100 tons per day.   |
| <b>Generator of waste</b>                  | Persons or establishments generating municipal solid waste.   |
| <b>Geographic information system (GIS)</b> | A system, usually computerised, that includes locations of all geographical characteristics of an area of land. Items may include elevation, houses, public utilities, or the location of bodies of water, aquifers, and flood plains.    |
| <b>Geotextile</b>                          | A synthetic component that is used as a filter to prevent the passing of fine-grained material such as silt or clay. A geotextile may be placed on top of a drainage layer to prevent the layer from becoming clogged with fine material. |
| <b>Goals</b>                               | Specific, discrete aims that define accomplishment of the vision and mission.   |
| <b>Grain size distribution</b>             | A method of categorizing soils in which soil particles are separated according to size. A well-graded soil has a uniform grain size distribution while a poorly graded soil has a non-uniform grain size distribution.                    |
| <b>Groundwater</b>                         | Water beneath the earth's surface that fills underground pockets (known as aquifers), supplying wells and springs.  |
| <b>Groundwater monitoring well</b>         | A well placed at an appropriate location and depth for taking water samples to determine groundwater quality in the area surrounding a landfill or other site.  |
| <b>Hammermill</b>                          | A type of crusher or shredder used to break materials up into smaller pieces.   |
| <b>Handling</b>                            | Includes all activities relating to sorting, segregation, material recovery, collection, secondary storage, shredding, baling, crushing, loading, unloading, transportation, processing and disposal of solid waste.                      |



|   |  |
|---|--|
| <b>Hazardous Waste (HW)</b>                                       | A waste that poses substantial or potential threats to public health or the environment generally exhibiting one or more of these characteristics: ignitable, oxidizing, corrosive, eco-toxic, radioactive, etc. Such wastes arising from industries are called as Industrial Hazardous Waste. |
| <b>Heat value</b>   | Heat generated per unit weight or volume of combustible material completely burned.  |
| <b>Heavy metals</b>   | Metals of high atomic weight and density that are toxic to living organisms, such as mercury, lead, and cadmium.   |
| <b>HELP (hydrologic evaluation of landfill performance) model</b> | A specialised computer program that performs the water balance equation and aids in modeling by predicting leachate generation. By selecting different covers and liners, an optimum combination can be achieved.  |
| <b>Household hazardous waste</b>                                  | Products used in residences that are toxic to living organisms and/or the environment, such as paints and some cleaning compounds.   |
| <b>Humus</b>  | The end product of composting which is a dark organic material forms after the decomposition of organic waste also called compost.   |
| <b>Hydraulic conductivity</b>                                     | The hydraulic conductivity of a soil is a measure of the soil's ability to transmit water when submitted to a hydraulic gradient. These properties determine the behavior of the soil fluid within the soil system under specified conditions.   |
| <b>Importer</b>   | A person who imports new lead acid batteries or components containing lead thereof for the purpose of sale.  |
| <b>Incineration</b>   | An engineered process involving burning or combustion of MSW to thermally degrade waste materials at high temperatures.  |
| <b>Industrial waste</b>   | Materials discarded from industrial operations or derived from manufacturing processes.  |
| <b>Inerts</b>   | Wastes which are not bio-degradable, recyclable or combustible and includes non recyclable fraction of construction and demolition waste, street sweeping or dust and silt removed from the surface drains.  |
| <b>Infiltration layer</b>   | A low hydraulic conductivity layer in a landfill, usually a component in the cover that is placed to minimise liquid infiltration to the waste layer.  |



|   |  |
|---|--|
| <b>Informal sector</b>                          | The part of an economy that is characterised by private, usually small-scale, labour-intensive, largely unregulated, and unregistered manufacturing or provision of services.  |
| <b>Inoculants</b>                               | Microbial concoction or natural material containing microbes, e.g., stabilised sewage sludge, cattle manure, and commercially available proprietary material to boost composting, e.g., EM solution.   |
| <b>Inorganic waste</b>                          | Waste composed of material other than plant or animal matter, such as sand, dust, glass, and many synthetics.  |
| <b>Institutional Generator</b>                  | Includes occupier of the institutional buildings such as building occupied by central government departments, state government departments, public or private sector companies, hospitals, schools, colleges, universities or other places of education, organisation, academy, hotels and restaurants.          |
| <b>Institutional waste</b>                      | Waste materials originating in schools, hospitals, prisons, research institutions, and other public buildings.   |
| <b>Integrated Solid Waste Management (ISWM)</b> | ISWM refers to a strategic initiative for the sustained management of solid waste through the use of a comprehensive integrated format generated through sustained preventive and consultative approach to the complementary use of a variety of practices to handle solid waste in a safe and effective manner. |
| <b>In-vessel composting</b>                     | Composting in an enclosed vessel or drum with a controlled internal environment, mechanical mixing, and aeration.  |
| <b>Itinerant waste buyer</b>                    | A person who moves around the streets buying (or bartering for) reusable and recyclable materials.   |
| <b>Kerbside collection</b>                      | Collection of compostable, recyclables, or trash at the edge of a sidewalk in front of a residence or a shop.  |
| <b>Key Performance Indicators (KPI's)</b>       | Parameters that provide a meaningful, concise, overall picture of an organisation's performance or that of the project/programme, used to report progress that is chosen to reflect the critical success factors of a program or plan. The KPI's reflect long-term considerations.                               |
| <b>Landfill gases</b>                           | Gases arising from the decomposition of organic wastes; principally methane, carbon dioxide, and hydrogen sulphide. Such gases may cause explosions at landfills.  |

|                                   |   |
|-----------------------------------|---|
| <b>Landfill mining</b>            | A process of removing reusable resources from old landfills for recycling.  |
| <b>Landfilling</b>                | The disposal of residual municipal solid waste on land in a facility designed with protective measures against pollution of ground water, surface water and air fugitive dust, wind-blown litter, bad odour, fire hazard, bird menace, pests or rodents, greenhouse gas emissions, slope instability and erosion. |
| <b>Leachate</b>                   | The liquid that seeps through solid waste or other medium and has extracts of dissolved or suspended material from it.  |
| <b>Leachate collection system</b> | Network of pipes or geotextiles/geonets placed at low areas of the landfill liner to collect leachate from a landfill for storage and treatment. Flow of leachate along the liner is facilitated by the use of a soil drainage blanket or geonet.   |
| <b>Leachate pond</b>              | A pond or tank constructed at a landfill to receive the leachate from the area. Usually the pond is designed to provide some treatment of the leachate, by allowing settlement of solids or by aeration to promote biological processes.  |
| <b>Liner</b>                      | a protective layer, made of soil and/or synthetic materials, installed along the bottom and sides of a landfill to prevent or reduce the flow of leachate into the environment.   |
| <b>Magnetic band</b>              | Magnets fixed on a moving belt or band which moves close to a surface (e.g., a belt conveyor) and continuously picks up ferrous material and sheds them systematically into a hopper or another conveyor belt.  |
| <b>Magnetic separation</b>        | A system to remove ferrous metals from other materials in a mixed municipal waste stream. Magnets are used to collect the ferrous metals.   |
| <b>Manufacturer</b>               | In relation to any factory manufacturing lead acid batteries or components thereof means a person or Chief Executive Officer (CEO) of the company who has control over the affairs of the factory or the premises for sale and collection of lead acid batteries or components thereof.                           |
| <b>Market waste</b>               | Primarily organic waste, such as leaves, skins, and unsold food, discarded at or near food markets.   |

|  |  |
|--|--|
| <b>Mass burn incinerator</b>                   | A type of incinerator in which solid waste is burned without prior sorting or processing.  |
| <b>Material recovery facility (MRF)</b>        | A facility where non-combustible solid waste can be temporarily stored by the urban local body or any person authorised by the urban local body to facilitate segregation, sorting and recovery of various components of waste by informal sector of waste pickers or any other work force engaged for the purpose before the waste is delivered or taken up for its processing or disposal.   |
| <b>Mechanical separation</b>                   | A system to remove ferrous metals from other materials in a mixed municipal waste stream. Magnets are used to collect ferrous metals.  |
| <b>Methane</b>                                 | An odourless, colourless, flammable, explosive gas, CH <sub>4</sub> , produced by anaerobically decomposing MSW at landfills.  |
| <b>Moisture content</b>                        | The fraction or percentage of a substance or soil that is water.   |
| <b>Municipal Authority</b>                     | The Municipal Corporation, Nagar Nigam, Municipal council, Nagar Palika Nagar palika Parishad, Nagar Panchyat, Town panchayat , notified industrial township, notified area committee (NAC) and any other peri urban area declared as census town or urban centre during publication of 2011 census of India or any other urban local body constituted under the Acts for time being in force and, where the management and handling of municipal solid waste is entrusted to such agency.       |
| <b>Municipal Solid Waste (MSW)</b>             | Includes the domestic waste, commercial waste, institutional waste, market waste and other non residential wastes, street sweepings, silt removed/collected from the surface drains, horticulture waste, construction and demolition (C&D) waste and treated bio-medical waste excluding industrial hazardous waste, and e-waste generated in any municipal authority area in either solid or semi-solid form.   |
| <b>Municipal Solid Waste Management (MSWM)</b> | Planning, implementation and enforcement of reduction, re-use, recovery and recycling of municipal solid waste in a scientific and hygienic manner, the storage of segregated municipal solid waste at source, primary collection from the source of waste generation, street sweeping, removal of silt from the surface drains, storage and collection of C&D waste, dairy waste, horticulture waste, secondary storage, transportation, processing and safe disposal of municipal solid waste. |

|  |  |
|--|--|
| <b>Mulch</b>   | Ground up or mixed yard trimmings placed around plants to prevent evaporation of moisture and freezing of roots and to nourish the soil.   |
| <b>Municipal (project) revenue bond</b>                          | A method of financing in which bonds are given on the basis of the worthiness, technological feasibility, and projected revenue of a project.  |
| <b>Non-biodegradable Waste</b>                                   | Any waste that cannot be degraded by micro organisms into simpler stable compounds.  |
| <b>Occupier</b>  | A person having the administrative control over the institution and the premises generating bio-medical waste which includes a hospital, nursing home, clinic, dispensary, veterinary institution, animal house, pathological laboratory, blood bank, health care facility, and clinical establishments by whatever name it may be called. |
| <b>Operator of a common bio-medical waste treatment facility</b> | A person who owns, or controls or operates, for the collection, reception, transport, storage, treatment, disposal or any other form of handling bio-medical wastes.   |
| <b>Operator of facility</b>                                      | A person or entity, who owns or operates a facility for handling solid waste which includes the urban local body and any other entity or agency appointed by the urban local body.   |
| <b>Organic compost</b>   | Compost made from raw materials, which may include materials of biological origin (plant, animal) such as food waste, horticultural waste, fruit / vegetable / meat / fish market waste, chemically unprocessed minerals etc. (such as, rock phosphate).   |
| <b>Organic material (Organic waste)</b>                          | Composed of organic components containing carbon and other chemical compounds. The organic fraction of MSW includes paper, wood, food scraps, plastics, and yard trimmings.  |
| <b>Original equipment manufacturer</b>                           | Manufacturer of equipment or product using lead acid batteries as a component.   |
| <b>Orphaned products</b>   | Non branded or assembled electrical and electronic equipment as specified in the Schedule I, or those products by a company, which has closed its operations or has stopped product support.   |

|                                |  |
|--------------------------------|--|
| <b>Particulate matter (pm)</b> | Tiny pieces of matter resulting from the combustion process. PM can have harmful health effects when breathed. Pollution control at combustion facilities is designed to limit particulate emissions.                |
| <b>Passive venting</b>         | A venting technique using the natural pressure created in landfills to expel gases and control gas migration.  |
| <b>Pathogens</b>               | Disease-causing agents, especially microorganisms such as bacteria, viruses, and fungi.  |
| <b>Pelletisation</b>           | A process whereby small cubes or cylindrical pieces are made out of segregated combustible solid wastes.   |
| <b>Percolate</b>               | To filter gradually through a porous or a permeable substance. Groundwater may percolate into the bottom of an unlined landfill.   |
| <b>Permeability</b>            | A measure of how well a liquid moves through the pores of a solid. Expressed as a number applied to landfills in terms of how quickly water moves through soil; it is typically expressed as centimeters per second. |
| <b>Permeable</b>               | Having pores or openings that permit liquids or gasses to pass through.  |
| <b>Phase diagram</b>           | A diagram (or a series of diagrams) used to show chronological order in a project. The diagram should show key transition points and contain enough detail to move smoothly from phase to phase.                     |
| <b>Phasing</b>                 | A system of running a project in more than one step (phase). Each phase is generally independent of the others, which offers more flexibility in management and operation.   |
| <b>Plastic</b>                 | Material which contains as an essential ingredient a high polymer and which at some stage of its processing into its finished products can be shaped by flow.  |
| <b>Plastic waste</b>           | Any plastic product such as carry bags, pouches or multi-layered packages which have been discarded after use or after their intended life is over.  |
| <b>Platform</b>                | A type of transfer station that has a waste storage capacity of several days or more. While the waste is in temporary storage, recyclable materials may be removed.  |

|                                |   |
|--------------------------------|---|
| <b>Post-closure care</b>       | A procedure of maintaining the environmental controls and appearance of a landfill after it has ceased to accept waste.   |
| <b>Post-consumer recycling</b> | The reuse of materials generated from residential and commercial waste, excluding recycling of material from industrial processes that has not reached the consumer, such as glass broken in the manufacturing process.   |
| <b>Precycling</b>              | The decision-making process consumers use to judge a purchase based on its waste implications. Criteria include whether a product is reusable, durable, and repairable; made from renewable or non-renewable resources; over-packaged; or in a reusable container.  |
| <b>Prescribed Authority</b>    | The Authority declared as State Pollution Control Board or Pollution Control Committee for Union Territory under rule 4 and made responsible to perform the duties and undertake responsibilities as specified in rule 5.   |
| <b>Primary collection</b>      | Collecting, lifting and removal of segregated solid waste from source of its generation including households, shops, offices and any other non-residential premises or from any collection points or any other location specified by the urban local body.  |
| <b>Primary leachate</b>        | When waste enters a landfill, it contains some amount of liquid, which leaches out of the refuse as primary leachate.   |
| <b>Processing</b>              | The process by which municipal solid waste is transformed into new or recycled products.  |
| <b>Producer</b>                | Means any person who, irrespective of the selling technique used, 1. Manufacturers and offers to sell electrical and electronic equipment under his own brand; or 2. Offers to sell under his own brand, assembled electrical and electronic equipment produced by other manufacturers or suppliers; or 3. Offers to sell imported electrical and electronic equipment. |
| <b>Reconditioner</b>           | A person involved in repairing of lead acid batteries for selling the same in the market.   |
| <b>Recycler</b>                | An occupier who processes used lead acid batteries or components thereof for recovering lead.   |
| <b>Recycling</b>               | The process of transforming segregated solid waste into a new product or a raw material for producing new products.   |

|                                  |  |
|----------------------------------|--|
| <b>Redevelopment</b>             | Rebuilding of old residential or commercial buildings at the same site, where the existing buildings and other infrastructures have become dilapidated.  |
| <b>Refractory</b>                | A material that can withstand dramatic heat variations. Used in conventional combustion chambers in incinerators.  |
| <b>Refuse Derived Fuel (RDF)</b> | Segregated combustible fraction of solid waste other than chlorinated plastics in the form of pellets or fluff produced by drying, shredding, dehydrating and compacting combustible components of solid waste that can be used as fuel.   |
| <b>Registered recycler</b>       | A recycler registered with the Ministry of Environment and Forests or an agency designated by it for reprocessing used lead acid batteries or components thereof.  |
| <b>Registration</b>              | The process of authentication of the facility run by an operator (NGO, CBO, private company), which would ensure standard operating procedure and produce material in compliance with applicable quality standards. This would be done in a time bound manner – initially for one year, to be renewed on yearly basis subject to appropriate inspection of the premises and sampling of the compost produced for quality check. Valid registration would be a pre-condition for consideration of any assistance from the Government or the Local Body. |
| <b>Residual waste</b>            | Includes the waste and rejects from the solid waste processing facilities which are not suitable for recycling or further processing.  |
| <b>Resource recovery</b>         | A term describing the extraction and use of materials and energy from the waste stream. The term is sometimes used synonymously with energy recovery.  |
| <b>Reuse</b>                     | The use of a product more than once in its same form for the same purpose; e.g., a soft drink bottle is reused when it is returned to the bottling company for refilling.  |
| <b>Rotary screen</b>             | A round screen which moves either on its axis or preferably moved from outside, so that the material inside goes through ‘cascading’ action. The feeding side is kept slightly higher than the discharge side.   |



|                             |  |
|-----------------------------|--|
| <b>Sanitary landfill</b>    | The final and safe disposal of residual solid waste and inert wastes on land in a facility designed with protective measures against pollution of ground water, surface water and fugitive air dust, wind-blown litter, bad odour, fire hazard, animal menace, bird menace, pests or rodents, greenhouse gas emissions, persistent organic pollutants slope instability and erosion. |
| <b>Sanitary waste</b>       | Wastes comprising of used diapers, sanitary towels or napkins, tampons, condoms, incontinence sheets and any other similar waste.  |
| <b>Scavenging</b>           | At a landfill or material recovery facility, scavenging is the uncontrolled separation of recyclable and reusable materials. Uncontrolled means that the operator does not monitor the removal of materials, and in many cases prohibits it. Material scavenging of recyclables may also occur at the curb or at drop-off centres.   |
| <b>Scrap</b>                | Discarded or rejected industrial waste material often suitable for recycling.  |
| <b>Scrubber</b>             | Common anti-pollution device that uses a liquid or slurry spray to remove acid gases and particulates from municipal waste combustion facility flue gases.   |
| <b>Secondary collection</b> | Collection of solid waste deposited at secondary waste storage depots or bins for onward transportation of the waste to the processing or disposal facility.   |
| <b>Secondary material</b>   | A material that is used in place of a primary or raw material in manufacturing a product.  |
| <b>Secondary storage</b>    | The temporary containment of solid waste at a public place in a covered bin or containers in a manner so as to prevent littering, vectors, stray animals and foul odour.   |
| <b>Segregation</b>          | Sorting and separate storage of various components of solid waste namely biodegradable wastes or wet waste, non biodegradable wastes or dry waste including recyclable waste, combustible waste sanitary waste and non recyclable inert waste, domestic hazardous wastes, E-waste and construction and demolition wastes.  |
| <b>Service Provider</b>     | An authority providing public utility services like water, sewerage, electricity, telephone, roads, drainage etc.  |

|   |  |
|---|--|
| <b>Settlement</b>   | As refuse decomposes and/or becomes compacted by the weight of overlaying layers, landfills experience a volume decrease and compaction of individual layers of waste in the landfill. Settlement refers to this volume decrease and compaction of layers.   |
| <b>Shredder</b>   | A mechanical device used to break waste materials into smaller pieces by tearing and impact action. Shredding solid waste is done to minimise its volume or make it more readily combustible.  |
| <b>Sludge</b>   | A semi-liquid residue remaining from the treatment of municipal and industrial water and wastewater.   |
| <b>Sorting</b>  | Separation of recyclables into various categories such as paper, plastic, metal, glass, etc including further separation of such material into varying grades as may be appropriate to facilitate cost effective recycling;  |
| <b>Source reduction</b>   | The design, manufacture, acquisition, and reuse of materials so as to minimise the quantity and/or toxicity of waste produced. Source reduction prevents waste either by redesigning products or by otherwise changing societal patterns of consumption, use, and waste generation. (See also, “waste reduction”). |
| <b>Source separation</b>  | The segregation of specific materials at the point of generation for separate collection. Residential generators source separate recyclables as part of curbside recycling programs.   |
| <b>Special waste</b>  | Refers to items that require special or separate handling, such as household hazardous wastes, bulky wastes, tires, and used oil.  |
| <b>Stabilizing</b>  | The biological decomposition of biodegradable wastes to a stable state where it generates no leachate or offensive odours and is fit for application to farm land ,soil erosion control and soil remediation.  |
| <b>Stacking</b>   | Arranging raw material in piles or heaps.  |
| <b>State Pollution Control Board or Pollution Control Committee</b> | The State Pollution Control Board or the Pollution Control Committee, as the case may be, constituted under sub-section (1) of section 4 of the Water (Prevention and Control of Pollution) Act, 1974.   |

|                                    |   |
|------------------------------------|---|
| <b>Static pile</b>                 | A composting pile which is not turned for aeration. Instead, air is passed through the windrows by using perforated pipes and air blowers.  |
| <b>Storage</b>                     | The temporary containment of municipal solid waste in a manner so as to prevent littering, attraction to vectors, stray animals and excessive foul odour.   |
| <b>Street Vendor</b>               | A person engaged in vending of articles, goods, wares, food items or merchandise of everyday use or offering services to the general public, in a street, lane, side walk, footpath, pavement, public park or any other public place or private area, from a temporary built up structure or by moving from place to place and includes hawker, peddler, squatter and all other synonymous terms which may be local or region specific; and the words “street vending” with their grammatical variations and cognate expressions, shall be construed accordingly. |
| <b>Thermophilic microorganisms</b> | Heat-loving microorganisms that thrive in and generate temperatures above 105 degrees Fahrenheit.   |
| <b>Tipping fee</b>                 | A fee or support price determined by the urban local body or any state agency authorised by the state government to be paid to the concessionaire or operator for handling one or more components of solid waste.   |
| <b>Tipping floor/pit</b>           | Unloading area for vehicles that are delivering municipal solid waste to a transfer station or municipal waste combustion facility.   |
| <b>Transfer station</b>            | A permanent facility where waste materials are taken from smaller collection vehicles and placed in larger vehicles for transport, including truck trailers, railroad cars, or barges. Recycling and some processing may also take place at transfer stations.  |
| <b>Transportation</b>              | Conveyance of solid waste, either treated, partly treated or untreated from a location to another location in an environmentally sound manner through specially designed and covered transport system so as to prevent the foul odour, littering and unsightly conditions.  |
| <b>Treated Bio medical wastes</b>  | The wastes generated in hospitals and health care institutions which have been prescribed as treated in accordance with the Bio-medical Waste (Management and Handling) Rule 1998, as amended from time to time.  |

|                                    |  |
|------------------------------------|--|
| <b>Treatment</b>                   | The method, technique or process, designed to modify physical, chemical or biological characteristics or composition of any waste so as to reduce its potential to cause harm.   |
| <b>Trommel</b>                     | An improved version of rotary screen, which is driven from outside, preferably using hydraulic power packs to keep the movement smooth, especially while starting after a power cut. The screen is covered from outside to control dust.   |
| <b>Turning</b>                     | The material in a pile or windrow is moved in a manner that the material in the core area comes out on the surface so that the whole windrow gets exposed to air by turn.  |
| <b>Used batteries</b>              | Used, damaged and old lead acid batteries or components thereof.   |
| <b>Urban Local Body</b>            | The purpose of these rules means and includes the municipal corporation, nagar nigam, municipal council, nagar palika, nagar palika parishad, municipal board, nagar panchayat, town panchayat, notified area committee or any other local body constituted under the relevant statutes where management of solid waste is entrusted to such agency including the body in notified industrial township, notified area, villages declared outgrowth in urban agglomeration by the Registrar General and Census Commissioner of India from time to time. |
| <b>User fee</b>                    | A fee imposed through a bye-law by the urban local body on the waste generator.  |
| <b>Vector</b>                      | An organism or insect which often carries diseases or parasites from one animal or plant to another, e.g., fly, mosquito etc.  |
| <b>Vermicast/<br/>vermicompost</b> | The excrement from earthworms, which is also called vermicompost.  |
| <b>Vermicomposting</b>             | A process of conversion of bio-degradable waste into compost using earthworms.   |
| <b>Viability Gap<br/>Funding</b>   | Financial support determined by the urban local body or authorised State Government or Central Government agency to be paid to the concessionaire or operator of a solid waste processing facility based on the output quantity of compost, biogas produced or energy or power generated so as to cover or partly cover the difference between market price of the output and its production cost plus reasonable profit margin  |

|                                     |  |
|-------------------------------------|--|
| <b>Vibro-screen</b>                 | A screening arrangement, in which flat screens vibrate in a horizontal plane; less expensive than trommel but less efficient.  |
| <b>Virgin plastic</b>               | Plastic material which has not been subjected to use earlier and has also not been blended with scrap or waste.  |
| <b>Waste generators</b>             | Includes every person or group of persons or residential and commercial establishments including Indian Railways and Defense cantonments which generate solid waste.   |
| <b>Waste pickers</b>                | A person or groups of persons engaged in collection of reusable and recyclable solid waste from the source of waste generation as well as picking up of wastes from the streets, bins, processing and waste disposal facilities for sale to recyclers directly or through intermediaries to earn their livelihood. |
| <b>Waste reduction</b>              | Waste reduction is a broad term encompassing all waste management methods—source reduction, recycling, composting—that result in reduction of waste going to a combustion facility or landfill.  |
| <b>Waste stream</b>                 | A term describing the total flow of solid waste from homes, businesses, institutions and manufacturing plants that must be recycled, burned, or disposed of in landfills; or any segment thereof, such as the “residential waste stream” or the “recyclable waste stream.”   |
| <b>Waste-to-Energy system (WTE)</b> | A method of converting MSW into a usable form of energy, usually through combustion.   |
| <b>Water balance</b>                | An equation that is used to model and predict the amounts of water that will go to various destinations. Typical destinations include evaporation, infiltration, and run-off. The sum of the amounts to the destinations must be equal to the source of the water (usually precipitation).                         |
| <b>Water table</b>                  | The level below the earth’s surface at which the ground becomes saturated with water. Landfills and composting facilities are designed with respect to the water table in order to minimise potential contamination.   |
| <b>Wet scrubber</b>                 | Anti-pollution device in which a lime slurry (dry lime mixed with water) is injected into the flue gas stream to remove acid gases and particulates.   |



**Wet/dry collection systems**

A collection system that allows wet organic materials to be separated by generators from dry wastes. Wet organic materials are suitable for composting, while dry materials are non-organics that may include recyclables.

**Windrow**

Long trapezoidal heaps or piles. Long composting heaps are referred to as 'windrow'. The base is wider and the top is narrower.



# Bibliography





- All India Institute of Local Self Government (2012). *Reference Material on Municipal Solid Waste Management for Urban Local Bodies – Collection, Transfer and Transportation of Waste Components*. Part I. Mumbai: India.
- All India Institute of Local Self Government (2012). *Reference Material on Municipal Solid Waste Management for Urban Local Bodies – Processing Options*. Part II. Mumbai: India.
- Anthena Infonomics (2012). *Public Private Partnership in Municipal Solid Waste Management- Potential and Strategies*. India.
- Blue Ridge Environmental Defense League (2009). *Waste Gasification: Impacts On the Environment and Public Health*.
- Brent Hansen Environmental (2004). *Operational Manual for Establishment of a Commercial Composting Facility*.
- British Columbia (1996). *Composting Factsheet*.
- Bureau of Indian Standards (1998). *Indian Standard- Guidelines for Recycling of Plastics*. New Delhi: Government of India.
- Central Pollution Control Board (2013). *An Overview on Plastic Waste Management*. New Delhi.
- Central Pollution Control Board (2012). *Status Report on Municipal Solid Waste Management*. New Delhi.
- Central Pollution Control Board (2011-12). *Annual Report*.
- Central Pollution Control Board (2011) *Implementation of E-Waste Rules, 2011*. New Delhi.
- Central Pollution Control Board (2010). *Guidelines on Co – processing in Cement/Power/Steel Industry*.
- Central Pollution Control Board (2010). *Urban Waste Profile*. ENVIS Centre for Control of Pollution. New Delhi
- Central Pollution Control Board (2003). *Guidelines for the Selection of Site for Landfilling*. New Delhi.
- Central Pollution Control Board (n.d.) *Sanitation in Slaughter House*. Pollution Control Implementation Division – III. New Delhi.
- Central Pollution Control Board (n.d.). *Plastic Waste Management*.
- Central Pollution Control Board (n.d.). *Slaughterhouse Waste Management*.

- Chikarmane, P. (2012). *Integrating Waste Pickers into Municipal Solid Waste Management in Pune*. WIEGO. Pune: India.
- Chikarmane, P., Narayan, L.; Chaturvedi, B (2008), *Recycling livelihoods – Integration of the Informal Recycling Sector in Solid Waste Management in India*. May, 2008. Study prepared for GTZ's sector project "Promotion of concepts for pro-poor and environmentally friendly closed-loop approaches in solid waste management" (unpublished).
- Cointreau-Levine, S., & Coad, A. (2000). *Guidance Pack: Private Sector Participation in Municipal Solid Waste Management*. Swiss Centre for Development Cooperation in Technology and Management. St. Gallen; Switzerland.
- Cointreau-Levine, S. (1994). *Private Sector Participation in Municipal Solid Waste Services in Developing Countries (Vol. 1)*. Urban Management Programme Discussion Paper 13, The World Bank; Washington, DC.
- Cointreau- Levine, S. (n.d.). *Transfer Station Design Concepts for Developing Countries*.
- Commissionerate of Municipal Administration (2008). *Ready Reckoner on Municipal Solid Waste Management for Urban Local Bodies*. Chennai: Government of Tamil Nadu.
- DEFRA (2007). *Introductory Guide to Options for the Diversion of Biodegradable Municipal Waste from Landfill*. United Kingdom.
- Department of Environment and Conservation (2009). *Environmental Guidelines for Construction and Demolition Waste Recycling Facilities*.
- Department of Environment and Conservation (2004). *Composting and Related Organic Processing Facility*. Government of Australia. Sydney.
- Department of Environment, Health and Natural Resources (1997). *Analysis of the Full Costs of Solid Waste Management for North Carolina Local Governments*. Division of Pollution Prevention and Environmental Assistance; Raleigh, North Carolina.
- Department of Solid Waste Operations (2009). *Material Recovery Facility Technology Review*. St Petersburg: Pinellas County.
- Dhokhikah, Y. & Trihadiningrum, Y. (2012). *Solid Waste Management in Asian Developing Countries: Challenges and Opportunities*. *Journal of Applied Environmental and Biological Sciences*, 2(7): 329-335.
- Directive 2000/76/EC of the European Parliament and of the Council (2000). *Incineration of Waste*.

- Dube, R., Nandan, V. & Dua, S. (n.d.) *Waste Incineration for urban India: Valuable contribution to Sustainable MSWM or Inappropriate high – tech solution affecting livelihood and public health?* New Delhi: GIZ.
- Eawag/Sandec- Waste Concern (2006). *Decentralized Composting for Cities of Low – Middle income countries*. Dhaka: Bangladesh
- Environmental Management Centre, LLP (2012). *Promoting Recycling in Municipal Solid Waste Management through Sustainable Business Models, Project Preparation Support for Livable Cities in Asia*.
- *Environmental Resources Management* (2000). *Strategic Planning Guide for Municipal Solid Waste Management*. The World Bank, SCD and DFID, Waste-Aware, London.
- European Commission (2006). *Reference Document on the Best Available Techniques for Waste Incineration*. Integrated Pollution Prevention and Control.
- Gendebien A. et al. (2003). *Refuse Derived Fuel, Current Practice and Perspectives*. European Commission.
- GHK (2006). *A study to examine the benefits of the End of Life Vehicles Directive and the costs and benefits of a revision of the 2015 targets for recycling, re-use and recovery under the ELV Directive*. Birmingham; United Kingdom.
- Ghosh, S., Ghosh, S. & Aich, A. (2011), *Rebuilding C&D Waste Recycling Efforts in India*. Waste Management World.
- GIZ (2011). *Recovering Resource, Creating Opportunities- Integrating the Informal Sector into Solid Waste Management*. Eschborn: Germany.
- GIZ-TERI (2011). *Environmental Fiscal Reforms in India: Where and How?* The Energy and Resources Institute. New Delhi.
- GIZ (2010). *Exploring Co-processing as an Option for Disposal of Certain Fractions of Municipal Solid Waste*.
- GIZ (n.d). *Economic Instruments in the Waste Management Sector*. Germany.
- GIZ (n.d). *Decentralized Windrow Composting*. New Delhi
- GIZ (n.d.). *Status Paper on Utilization of Refuse Derived Fuel (RDF) in India*.
- Gleis, M. (2010). *Experiences with other Thermal Treatment Processes- Reliability of new technologies*. Federal Environment Agency.

- Gokaldas, V. (2012). *Waste Picker-Run Biogas Plants as a Decentralized Solution*. In: On the Road to Zero Waste-Successes and Lessons From Around the World. GAIA: Mumbai.
- Government of Andhra Pradesh (2014). Municipal Administration & Urban Development Department- *Formulation of Andhra Pradesh Integrated Municipal Solid Waste Management Strategy*.
- Government of Karnataka (2010). *Policy on Integrated Solid Waste Management- Urban Development Department*.
- Hannan, M. A. et al. (2011). *Solid Waste Truck Monitoring and Management using RFID, GIS and GSM*. Journal of Applied Sciences Research, 7(12): 1961-1964.
- Holcim-GTZ (2007). *Reuse and Recycling of Construction and Demolition waste*.
- Indian Paper Manufacturers Association (2008). *Paper Manufacturers Pass Duty Cut Benefits to Consumers*.
- IL&FS Environment (2010). *Technical EIA Guidance Manual for Common Municipal Solid Waste Management Facility*. Ministry of Environment & Forests: New Delhi.
- IndiaMart. (2014). Road Side Twin Litter Bins.
- Jacobsen, H. & Kristoffersen, M. (2002). *Case Studies on waste minimization practices in Europe*. European Environment Agency. Copenhagen; Denmark.
- Kisliakova, A. (2005). *Decentralised Composting as an Approach towards a Sustainable Biowaste Management in Austria and Slovakia*. Austrian Society for Environment and Technology. Austria.
- Kuehl, R., Marti, M. & Schilling, J. (2008). *Resource for Implementing Street Sweeping Best Practices*. Local Road Research Board. Minnesota: US.
- MAIT-GTZ (2007). *E-waste Inventorisation in India, MAIT-GTZ study*. New Delhi.
- Mazumdar, N.B. (2007). *Composting Municipal Solid Waste: The Indian Scenario*. International Journal of Environmental Technology and Management, 7(3/4): 326-350.
- Ministry of Agriculture, Food and Fisheries (1996). *Composting Fact Sheet Series*. Abbotsford; British Columbia.

- Ministry of Environment and Forests (2011). *E Waste (Management and Handling) Rules, 2011*. *Gazette of India, S.O. 1125 (E)*. Government of India; New Delhi
- Ministry of Environment and Forests (2011). *Plastic Waste (Management and Handling) Rules, 2011*. Government of India; New Delhi
- Ministry of Environment and Forests (2009). *Plastics (Manufacture, Usage and Waste Management) Rules 2009*. *Gazette of India, S.O. 2400(E)*. Government of India. New Delhi.
- Ministry of Environment and Forests (2008). *Guidelines for Environmentally Sound Management of E- Waste*. New Delhi: CPCB.
- Ministry of Environment, Forest and Climate Change (2008). *National Action Plan on Climate Change*.
- Ministry of Environment and Forest (2006). *EIA Notification- 2006*. *Gazette of India, Extraordinary, Part-II, and Section 3, Sub – section (ii)*. Government of India: New Delhi.
- Ministry of Environment and Forests (2001). *Batteries (Management and Handling) Rules, 2001*. *Gazette of India, S.O. 432 (E)*. Government of India; New Delhi.
- Ministry of Environment & Forests (2000). *Municipal Solid Waste Management (Management & Handling) Rules, 2000*. *Gazette of India, S.O. 783 (E)*. Government of India. New Delhi
- Ministry of Environment and Forests (1998). *Bio-medical Waste (Management and Handling) Rules, 1998*. Government of India; New Delhi
- Ministry of Environment and Forests (1989). *Hazardous Waste (Management and Handling) Rules, 1989*. *Gazette of India, S.O. 594 (E)*. Government of India; New Delhi.
- Ministry of Finance (2011). *Draft National Public Private Partnership Policy*. Department of Economic Affairs; Government of India. New Delhi.
- Ministry of Finance (2011). *Toolkit for Public Private Partnership frameworks in Municipal Solid Waste, Volume I- Overview and Process*. Government of India.
- Ministry of Finance (2011). *Toolkit for Public Private Partnership frameworks in Municipal Solid Waste, Volume II- Case Study of PPP projects*. GoI-ADB.

- Ministry of Finance (2011). *Toolkit for Public Private Partnership frameworks in Municipal Solid Waste, Volume III- Model PPP Templates and Documentation*. GoI-ADB.
- Ministry of Finance (2011). *Toolkit for Public Private Partnership frameworks in Municipal Solid Waste, Volume IV- Baseline Status of MSWM in Selected Satellite Towns*. GOI-ADB.
- Government of Kerala (2013). Suchitwa Mission.
- Ministry of Urban Development (2012). *Toolkit for Solid Waste Management: Jawaharlal Nehru National Urban Renewal Mission*. Government of India. New Delhi.
- Ministry of Urban Development (2011). *Municipal Solid Waste Management on a Regional Basis-Guidance Note*. Government of India. New Delhi.
- Ministry of Urban Development (2008). *Handbook on Service Level Benchmarking*. Government of India. New Delhi.
- Ministry of Urban Development (2005) *Inter Ministerial Task Force on Integrated Plant Nutrient Management*. Government of India; New Delhi.
- Ministry of Urban Development (2005). *Report of the Technology Advisory Group on Solid Waste Management*. Government of India; New Delhi.
- Ministry of Urban Development (2000). *Manual on Municipal Solid Waste Management*. Central Public Health & Environment Engineering Organization: Government of India. New Delhi.
- Mohanram, N.S. (2012, July 20<sup>th</sup>). *Environmentally Friendly and Viable Recycling Infrastructure in India- Opening Remarks*. [PowerPoint Presentation]. Presented at: SIAM Recycling International Seminar.
- Nagavallemma, K.P., et al. (2006). *Vermicomposting: Recycling Wastes into Valuable Organic Fertilizer*. SAT eJournal, 2(1); 1-16.
- National Labour Commission (2002), Ministry of Labour, Government of India.
- Nithikul, J. (2007). *Potential of Refuse Derived Fuel Production from Bangkok Municipal Solid Waste*. Chulalongkorn University. Bangkok.
- Novelis Recycling (2014). *No other material offers the versatility and environmental benefits of aluminium*.
- Paradigm Environmental Strategies Private Limited- GIZ (2011). *Strategy for Improved Collection and Transportation of SWM in Tirupati City with additional resource*. Tirupati Municipal Corporation: India.

- Patil, R.K., Garnaik, B., Khond, M. P. & Nawale, L. G. (2010). *Environment Pollution Reduction in Cement Industry for Co Combustion of Waste Tyre and Coal as a Fuel*. International Journal of Modern Engineering Research, 2(6); 4652-4656.
- Paul, J. & Geesing, D. (n.d.) *Composting Facility Operator Manual*.
- Practical Action (n.d). *Home Composting Bins*.
- Rahman, M.H. & Sadre Gazhi, S. (2011) *Waste Concern: A Decentralized Community based Composting through Public Private Community Partnership*. UNDP: Bangladesh.
- Repa, E.W. (2003). *Bioreactor Landfill: A Viable Technology*. National Solid Waste Management Association. Washington, DC: USA.
- Rodrigues, S. (2013). *Panjim's Initiatives in Solid Waste Management*.
- Reschner, K., (2008). *Scrap Tire Recycling*.
- Ryan, M. (2010). *Environmental Standards for Municipal Solid Waste Compost Facilities*. Department of Environment and Conservation, Government of Newfoundland and Labrador.
- Rynk, R. et al. (1992). *On-Farm Composting HandBook*. Northeast Regional Agricultural Engineering Service. New York: USA.
- Sabbas, T., Poletini, A., Pomi, R. et. al (2003). *Management of municipal solid waste incineration residues*. Waste Management 23 (61-88).
- Schlegelmilch, K., Meyer, E. & Ludewig, D. (2010). *Economic Instruments in the Waste Management Sector – Experience from OECD and Latin American Countries*. GIZ. Berlin: Germany.
- Sikka, P. (n.d.) *Energy from MSW RDF Pelletization- A Pilot Indian Plant*. Department of Science & Technology. Government of India: New Delhi.
- *Statistical Data Analysis*. (n.d.).
- Staudinger, J. & Keoleian, G. A. (2001). *Management of End-of-Life Vehicles (ELVs) in the US*. The Center for Sustainable Systems. Ann Arbor: Michigan.
- Tetrapak (2014). *Go Green with Tetra Pak Recycling now Reaches Mumbaikars through nearly 130 carton collection points*.
- The Asian Foundation (2008). *Solid Waste Planning and Disposal – Service Delivery Training Module*. Sri Lanka.

- Trezek, G.J et al. (1979). *Predication of the Impact of Screening on refuse- derived fuel quality*. Electric Power Research Institute; California.
- Tyagi S., V Mohan., Roy Choudhary, K. e.al (2013). *Effective Recycling of Waste Paper for Production of Good Quality Newsprint*. IPPTA.
- UNEP (2009). *Converting Waste Plastics into a Resource*.
- UNEP (2009). *Developing Integrated Solid Waste Management Plan Training Manual– Volume 1: Waste Characterization and Quantification with Projection for Future, Training Manual*. Japan.
- UNEP (2009). *Developing Integrated Solid Waste Management Plan Training Manual – Volume 2: Assessment of Current Waste Management System and Gaps therein*. Japan.
- UNEP (2009). *Developing Integrated Solid Waste Management Plan Training Manual – Volume 3: Targets and Issues of Concern*. Japan.
- UNEP (2009). *Development Integrated Solid Waste Management Plan Training Manual – Volume 4: ISWM Plan*. Japan.
- UNEP (2007). *E- waste Management Manual- Volume-II*.
- UNEP (n.d.) *Sound Practices Composting*.
- UN ESCAP (2012). *Operational Manual on Composting for Integrated Resource Recovery Centre*.
- UN-HABITAT (2011). *Collection of Municipal Solid Waste- Key Issues for Decision- makers in Developing Countries*. Nairobi: Kenya.
- US Environmental Protection Agency (2014). *Wastes-Resource Conservation-Common Wastes & Materials- Paper Recycling*.
- US EPA (2000). *Bio- solids Technology Fact Sheet- In vessel composting of Bio solid*. Washington, DC: US.
- US EPA (1997). *Full Cost Accounting for Municipal Solid Waste Management: A Handbook*. Washington, DC: USA.
- US EPA (1995). *Decision Maker’s Guide to Solid Waste Management*.
- US EPA (1994). *Composting of Yard Trimmings and Municipal Solid Waste*. New York: USA.
- USDA (2000). *Environment Engineering National Engineering Hand Book*. Washington, DC: USA.
- Waste Minimization. (n.d.)



- Water and Sanitation Program (2007). *Implementing Integrated Solid Waste Management Systems in India- Moving Towards the Regional Approach*.
- Welsh, N., Schans, M. & Dethrasavong, C. (2005). *Monitoring and Evaluation System Manual*. Mekong Biodiversity Conservation and Sustainable Use Programme.
- White, L. (2002). *Extended Producer Responsibility: Container Deposit Legislation Report*. Zero Waste New Zealand Trust; Auckland.
- World Bank (1999). *Decision Makers' Guide to Municipal Solid Waste Incineration*. Washington, DC: USA.
- Zafar, S. (2009) *Gasification of Municipal Solid Waste*.
- Zhu, D. et.al. (2008). *Improving Solid Waste Management in India- A Sourcebook for Policy Makers and Practitioners*. The World Bank: Washington, DC.







सत्यमेव जयते

GOVERNMENT OF INDIA



एक कदम स्वच्छता की ओर

## CLEANLINESS PLEDGE

Mahatma Gandhi dreamt of an India which was not only free but also clean and developed. Mahatma Gandhi secured freedom for Mother India.

Now it is our duty to serve Mother India by keeping the country neat and clean.

I take this pledge that I will remain committed towards cleanliness and devote time for this.

I will devote 100 hours per year, that is two hours per week, to voluntarily work for cleanliness. I will neither litter nor let others litter.

I will initiate the quest for cleanliness with myself, my family, my locality, my village and my work place.

I believe that the countries of the world that appear clean are so because their citizens don't indulge in littering nor do they allow it to happen. With this firm belief, I will propagate the message of Swachh Bharat Mission in villages and towns.

I will encourage 100 other persons to take this pledge which I am taking today.

I will endeavour to make them devote their 100 hours for cleanliness.

I am confident that every step I take towards cleanliness will help in making my country clean.

### Do's

- Start cleanliness from home
- Keep surroundings clean and green
- Keep work place neat and clean
- Devote 2 hours a week on sanitation
- Dispose garbage in designated places.

### Don'ts

- Don't litter and don't let others litter
- Don't defecate and urinate in open
- Don't deface public properties
- Don't spit in public places
- Don't dump garbage in drains/water bodies

## Eligible Components Under Swachh Bharat Mission in Urban Local Bodies

Individual Household Toilets | Community Toilets | Public Toilets | Solid Waste Management

## MINISTRY OF URBAN DEVELOPMENT

Nirman Bhawan, New Delhi 110 011, India

[www.moud.gov.in](http://www.moud.gov.in)

[www.swachhbharaturban.gov.in](http://www.swachhbharaturban.gov.in)